

# AUTOMATIC TRANSMISSION

## CONTENTS

<b>GENERAL INFORMATION</b> .....	<b>23A- 0-3</b>
<b>1. SPECIFICATIONS</b> .....	<b>23A- 1-1</b>
<b>TRANSMISSION MODEL TABLE</b> .....	<b>23A- 1-1</b>
<b>SERVICE SPECIFICATIONS</b> .....	<b>23A- 1-3</b>
<b>VALVE BODY SPRING IDENTIFICATION</b> .....	<b>23A- 1-5</b>
<b>TORQUE SPECIFICATIONS</b> .....	<b>23A- 1-9</b>
<b>SEALANTS</b> .....	<b>23A-1-11</b>
<b>ADJUSTMENT SNAP RINGS AND SPACERS</b> .....	<b>23A-1-11</b>
<b>2. SPECIAL TOOLS</b> .....	<b>23A- 2-1</b>
<b>3. TRANSMISSION</b> .....	<b>23A- 3-1</b>
<b>4. OIL PUMP</b> .....	<b>23A- 4-1</b>
<b>5. OVERDRIVE CLUTCH</b> .....	<b>23A- 5-1</b>
<b>6. OVERDRIVE PLANETARY GEAR</b> .....	<b>23A- 6-1</b>
<b>7. OVERDRIVE BRAKE</b> .....	<b>23A- 7-1</b>
<b>8. FORWARD CLUTCH</b> .....	<b>23A- 8-1</b>
<b>9. DIRECT CLUTCH</b> .....	<b>23A- 9-1</b>
<b>10. CENTER SUPPORT</b> .....	<b>23A-10-1</b>
<b>11. FRONT PLANETARY GEAR</b> .....	<b>23A-11-1</b>
<b>12. REAR PLANETARY GEAR AND OUTPUT SHAFT</b> .....	<b>23A-12-1</b>
<b>13. BRAKE NO. 3</b> .....	<b>23A-13-1</b>
<b>14. GOVERNOR</b> .....	<b>23A-14-1</b>
<b>15. VALVE BODY</b> .....	<b>23A-15-1</b>
<b>16. TRANSFER</b> .....	<b>23A-16-1</b>
<b>17. REAR OUTPUT SHAFT &lt;V4AW2-1, V4AW2-3, 7 (PART TIME 4WD)&gt;</b> .....	<b>23A-17-1</b>
<b>18. REAR OUTPUT SHAFT &lt;V4AW2-3, 7 (SUPER SELECT 4WD)&gt;</b> .....	<b>23A-18-1</b>
<b>19. CENTER DIFFERENTIAL &lt;V4AW2-3, 7 (SUPER SELECT 4WD) only&gt;</b> .....	<b>23A-19-1</b>
<b>20. 2-4WD SYNCHRONIZER &lt;V4AW2-3, 7 (SUPER SELECT 4WD) only&gt;</b> .....	<b>23A-20-1</b>
<b>21. TRANSFER DRIVE SHAFT &lt;V4AW2-3, 7 (SUPER SELECT 4WD) only&gt;</b> .....	<b>23A-21-1</b>
<b>22. FRONT OUTPUT SHAFT</b> .....	<b>23A-22-1</b>
<b>23. INPUT SHAFT</b> .....	<b>23A-23-1</b>
<b>24. SPEEDOMETER SLEEVE</b> .....	<b>23A-24-1</b>

## GENERAL INFORMATION

### Precautions to be taken when disassembling and reassembling the transmission

- Because the automatic transmission is composed of component parts of an especially high degree of precision, these parts should be very carefully handled during disassembly and assembly so as not to scar or scratch them.
- A rubber mat should be placed on the workbench, and it should always be kept clean.
- During disassembly, cloth gloves or shop towels should not be used. If such items must be used, either use articles made of nylon, or use paper towels.
- All disassembled parts must be thoroughly cleaned.  
Metal parts may be cleaned with ordinary detergents, but must be thoroughly air dried.
- Clean the clutch disc, resin thrust plate and rubber parts by using ATF (automatic transmission fluid), being very careful that dust, dirt, etc. do not adhere to them.
- Do not reuse gaskets, oil seals, or rubber parts.  
Replace such parts with new ones at every reassembly. The O-ring of the oil level gauge need not be replaced.
- Do not use grease other than petrolatum jelly.
- Apply ATF to friction components, rotating parts, and sliding parts before installation.
- Do not apply sealer or adhesive to gaskets.
- When a bushing must be replaced, replace the assembly in which it is incorporated.
- If the transmission main unit is damaged, also disassemble and clean the cooler system.

MODEL R4AW2 – FOUR SPEED REAR WHEEL DRIVE TRANSMISSION

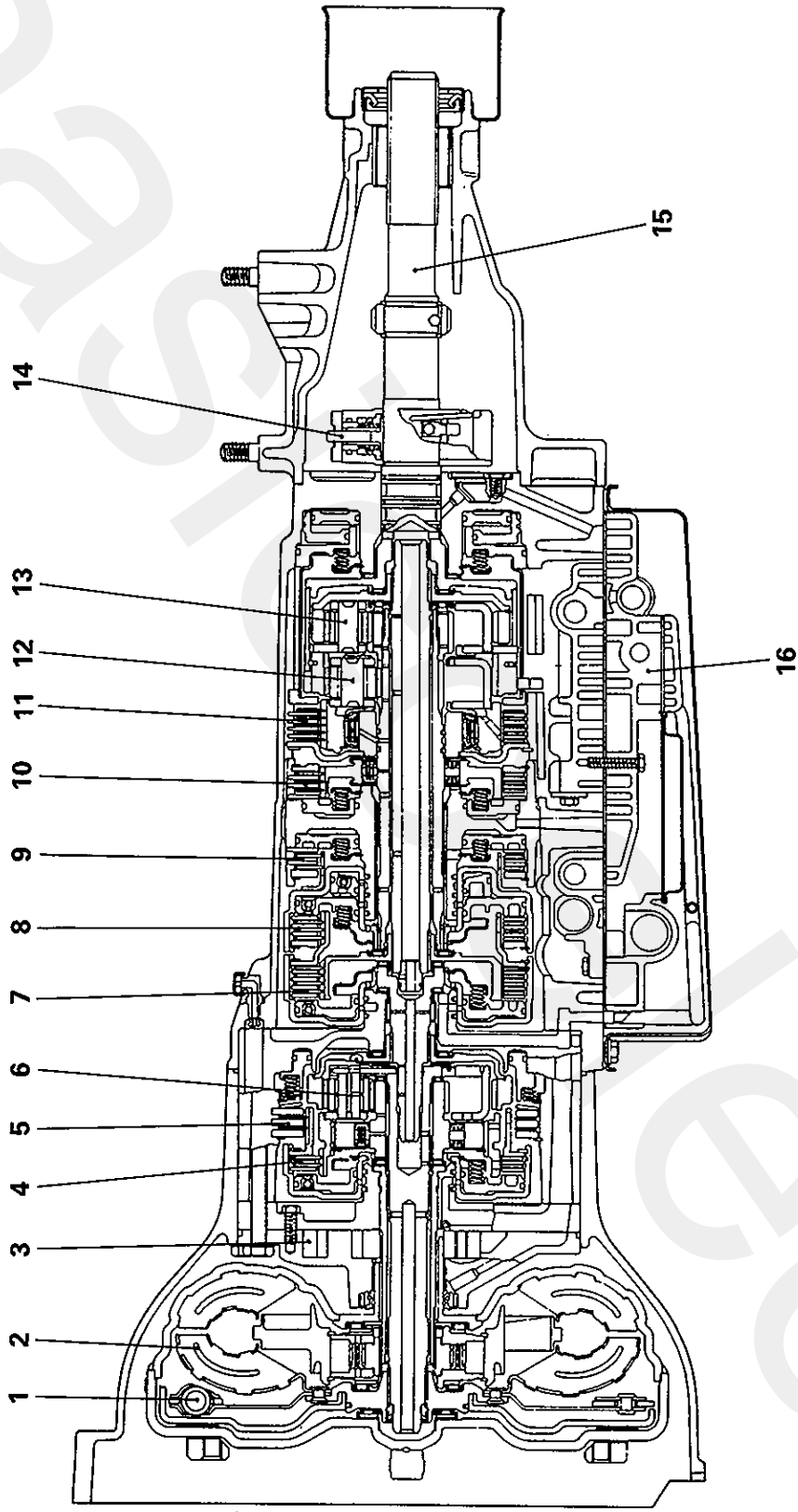

- |                             |                          |
|-----------------------------|--------------------------|
| 1. Lockup clutch            | 9. Brake No. 1           |
| 2. Torque converter         | 10. Brake No. 2          |
| 3. Oil pump                 | 11. Brake No. 3          |
| 4. Overdrive clutch         | 12. Front planetary gear |
| 5. Overdrive brake          | 13. Rear planetary gear  |
| 6. Overdrive planetary gear | 14. Governor             |
| 7. Forward clutch           | 15. Output shaft         |
| 8. Direct clutch            | 16. Valve body           |

MODEL V4AW2-1 – FOUR SPEED FOUR WHEEL DRIVE TRANSMISSION  
WITHOUT LOCK-UP CLUTCH

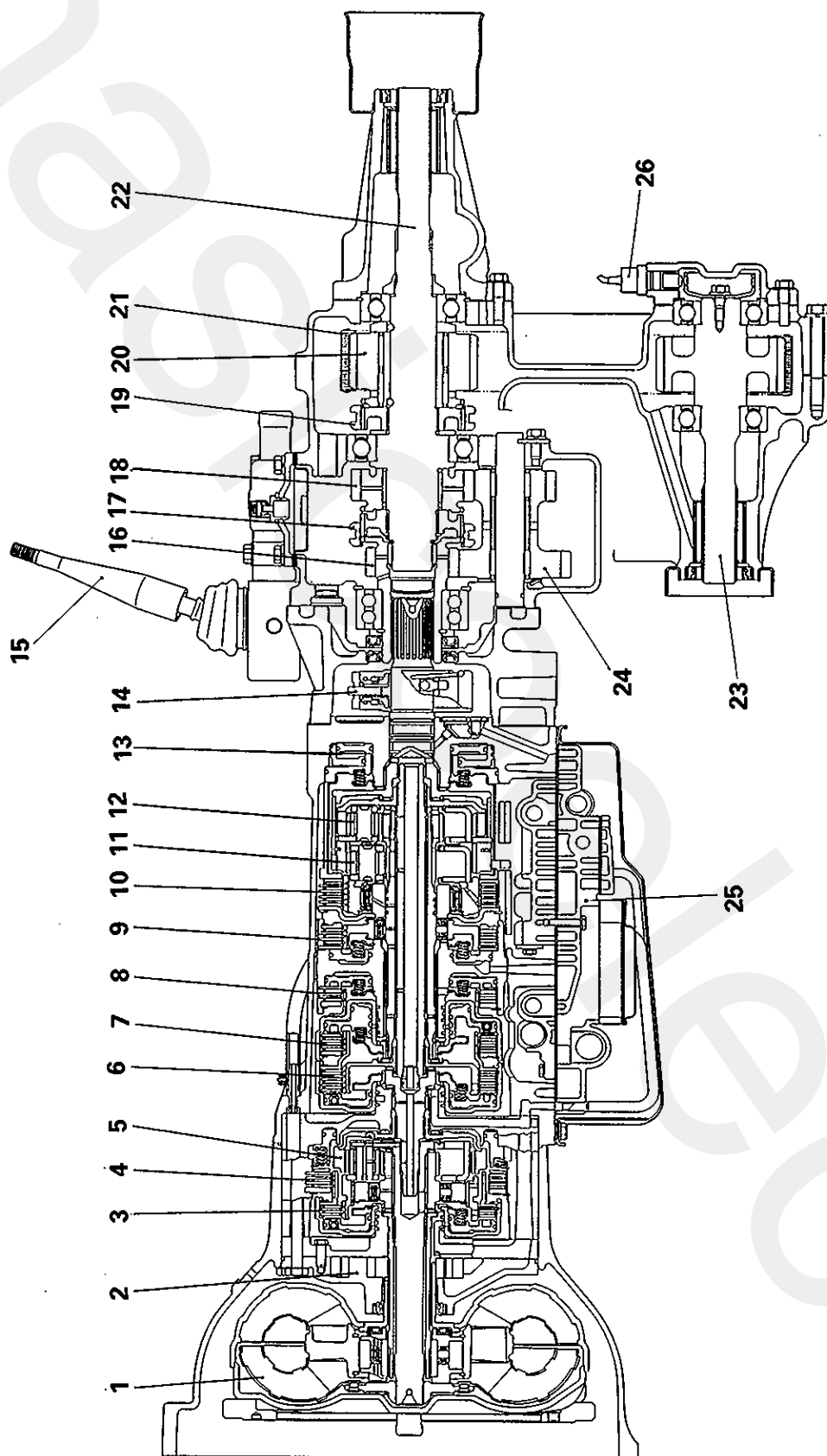

- 1. Torque converter
- 2. Oil pump
- 3. Overdrive clutch
- 4. Overdrive brake
- 5. Overdrive planetary gear
- 6. Forward clutch
- 7. Direct clutch
- 8. Brake No. 1
- 9. Brake No. 2
- 10. Brake No. 3
- 11. Front planetary gear
- 12. Rear planetary gear
- 13. Brake No. 3 piston
- 14. Governor
- 15. Transfer control lever
- 16. Input gear
- 17. High-low clutch
- 18. Low speed gear
- 19. 2WD-4WD clutch
- 20. Drive sprocket
- 21. Chain
- 22. Rear output shaft
- 23. Front output shaft
- 24. Counter gear
- 25. Valve body
- 26. Pulse generator

MODEL V4AW2-1 – FOUR SPEED FOUR WHEEL DRIVE TRANSMISSION WITH LOCK-UP CLUTCH

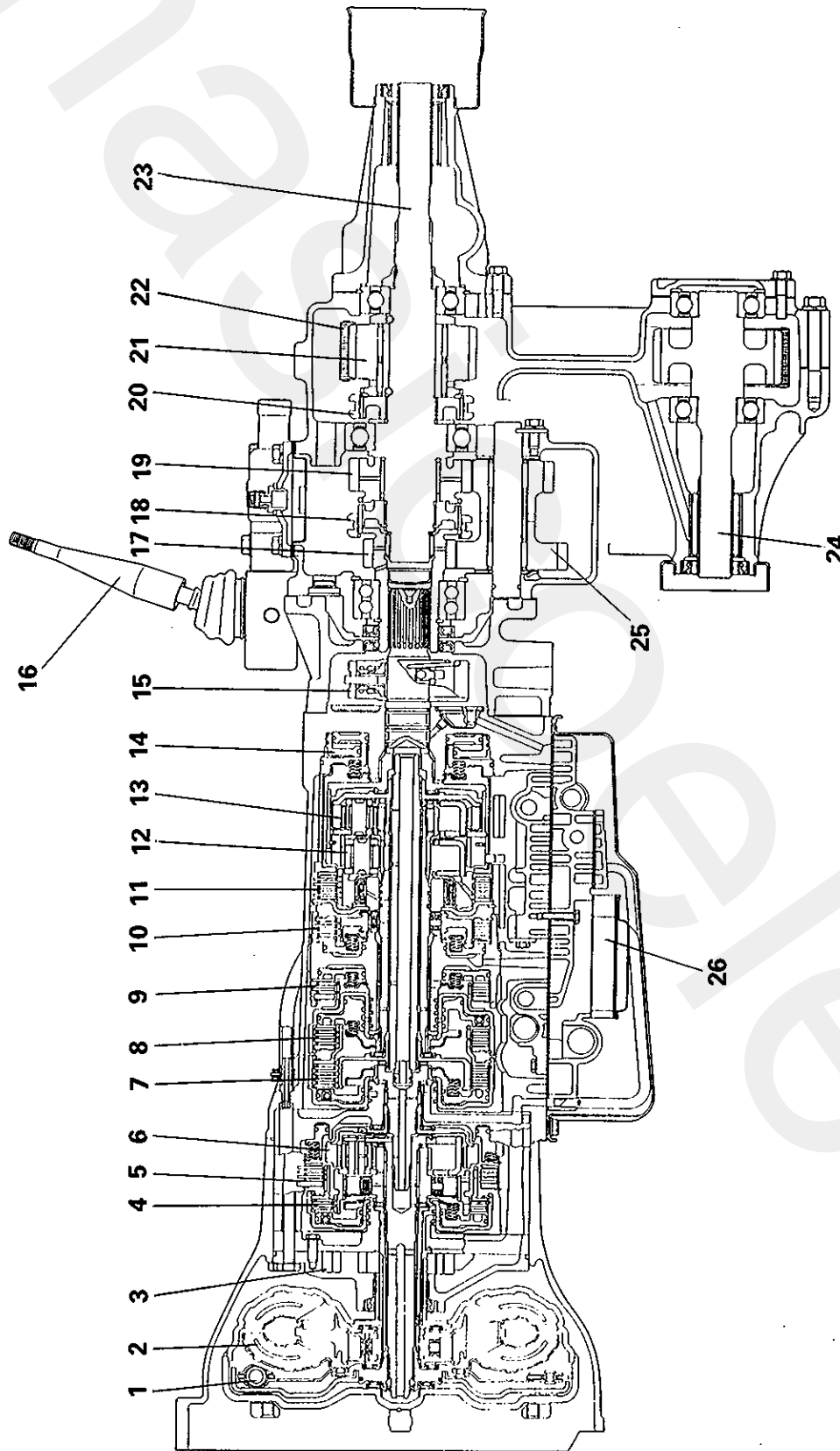

- 19. Low speed gear
- 20. 2WD-4WD clutch
- 21. Drive sprocket
- 22. Chain
- 23. Rear output shaft
- 24. Front output shaft
- 25. Counter gear
- 26. Valve body

- 10. Brake No. 2
- 11. Brake No. 3
- 12. Front planetary gear
- 13. Rear planetary gear
- 14. Brake No. 3 piston
- 15. Governor
- 16. Transfer control lever
- 17. Input gear
- 18. High-low clutch

- 1. Lockup clutch
- 2. Torque converter
- 3. Oil pump
- 4. Overdrive clutch
- 5. Overdrive brake
- 6. Overdrive planetary gear
- 7. Forward clutch
- 8. Direct clutch
- 9. Brake No. 1

**MODEL V4AW2-3, 7 – FOUR SPEED FOUR WHEEL DRIVE TRANSMISSION WITH LOCK-UP CLUTCH and VISCOUS COUPLING**

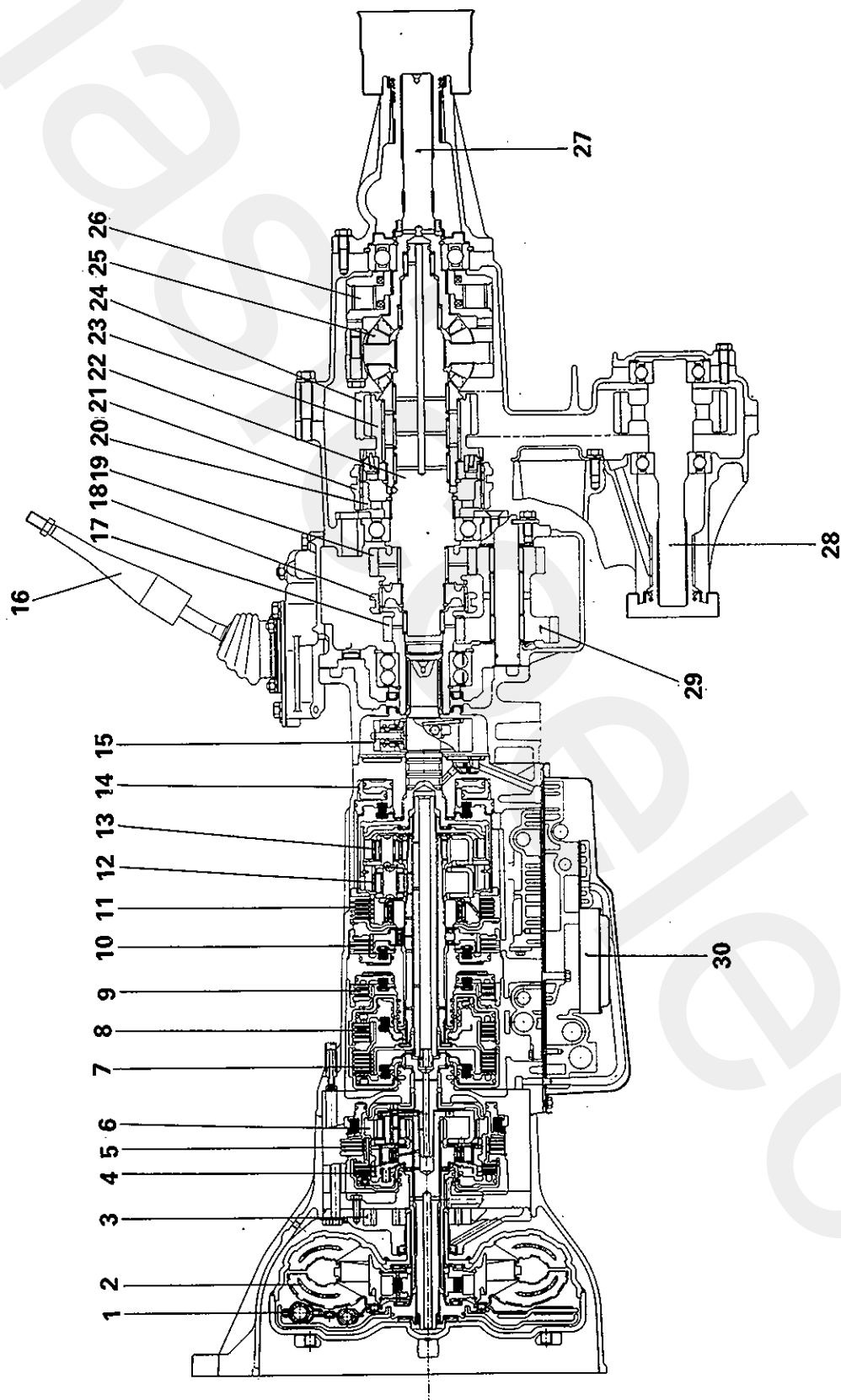

- |  |  |  |
|--|--|--|
| <ul style="list-style-type: none"> <li>1. Lockup clutch</li> <li>2. Torque converter</li> <li>3. Oil pump</li> <li>4. Overdrive clutch</li> <li>5. Overdrive brake</li> <li>6. Overdrive planetary gear</li> <li>7. Forward clutch</li> <li>8. Direct clutch</li> <li>9. Brake No. 1</li> <li>10. Brake No. 2</li> </ul> | <ul style="list-style-type: none"> <li>11. Brake No. 3</li> <li>12. Front planetary gear</li> <li>13. Rear planetary gear</li> <li>14. Brake No. 3 piston</li> <li>15. Governor</li> <li>16. Transfer control lever</li> <li>17. Input gear</li> <li>18. High-low clutch</li> <li>19. Low speed gear</li> <li>20. Differential lock hub</li> </ul> | <ul style="list-style-type: none"> <li>21. 2WD-4WD synchronizer sleeve</li> <li>22. Transfer drive shaft</li> <li>23. Drive sprocket</li> <li>24. Chain</li> <li>25. Center differential</li> <li>26. Viscous coupling</li> <li>27. Rear output shaft</li> <li>28. Front output shaft</li> <li>29. Counter gear</li> <li>30. Valve body</li> </ul> |
|--|--|--|

MODEL V4AW2-3, 7 – FOUR SPEED FOUR WHEEL DRIVE TRANSMISSION WITHOUT LOCK-UP COUTCH

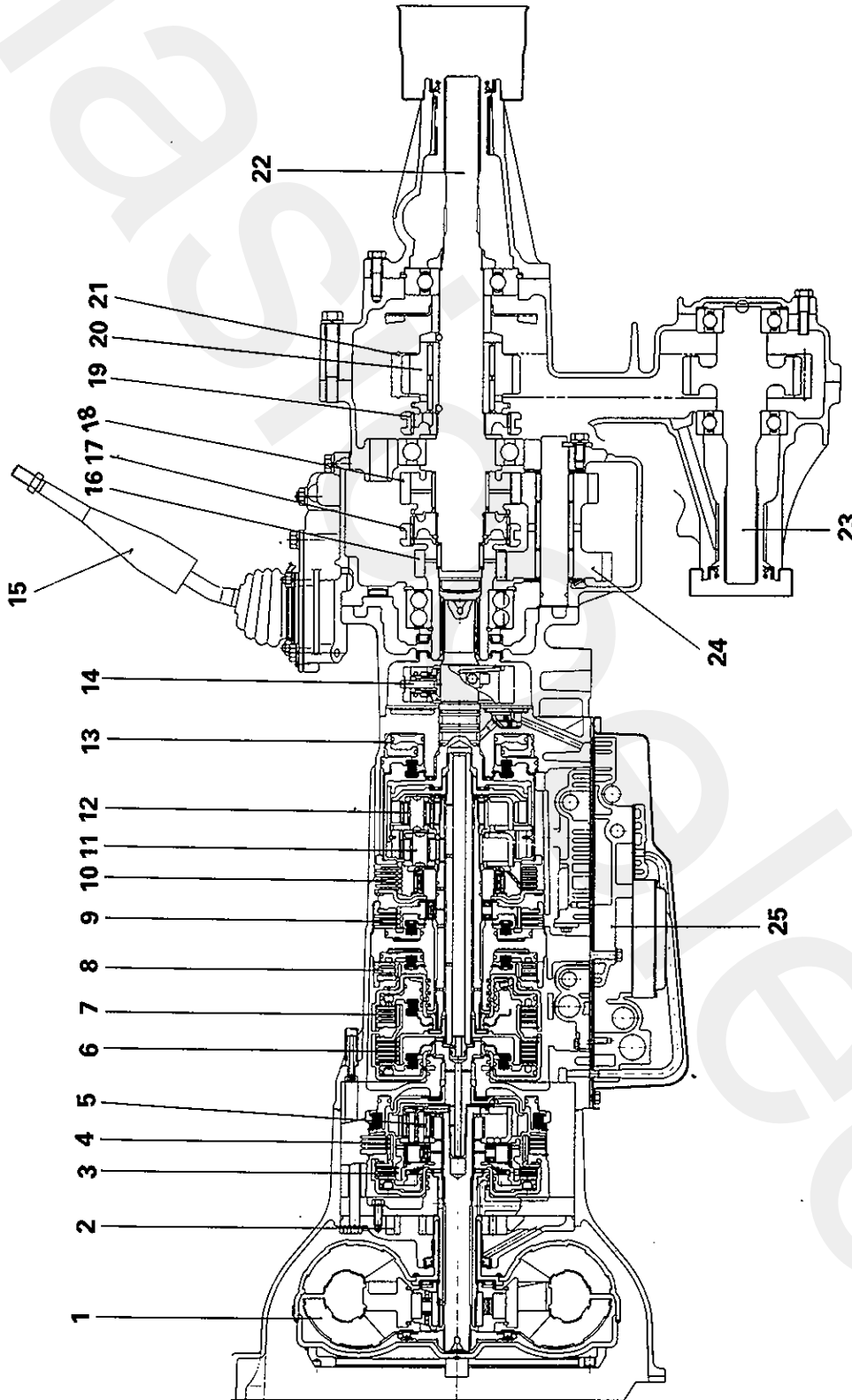

- 1. Torque converter
- 2. Oil pump
- 3. Overdrive clutch
- 4. Overdrive brake
- 5. Overdrive planetary gear
- 6. Forward clutch
- 7. Direct clutch
- 8. Brake No. 1
- 9. Brake No. 2
  
- 10. Brake No. 3
- 11. Front planetary gear
- 12. Rear planetary gear
- 13. Brake No. 3 piston
- 14. Governor
- 15. Transfer control lever
- 16. Input gear
- 17. High-low clutch sleeve
- 18. Low speed gear
  
- 19. 2WD-4WD clutch sleeve
- 20. Drive sprocket
- 21. Chain
- 22. Rear output shaft
- 23. Front output shaft
- 24. Counter gear
- 25. Valve body

**HYDRAULIC CONTROL SYSTEM for EC**

Owing to change of the 3rd – 4th upshift point, the hydraulic circuit around the 3rd – 4th shift valve has been changed as shown below. By this circuit change, detent regulator valve pressure no more acts on the upper part of the third coast shift valve.

In the OD condition, the shifting into 4th gear can be made even in the full throttle zone.

At the same time, the control for keeping the OD solenoid OFF up to the set speed and moving the 3rd ↔ 4th shift point to the high speed is added to ensure acceleration capability in the 3rd speed and full throttle zone. This control has been made possible by putting information from the detect switch (for detecting the throttle opening) and vehicle speed sensor into the OD solenoid drive relay control.

Addition of these two controls makes it possible to perform 3rd – 4th upshift when the set speed is exceeded in the full throttle zone.

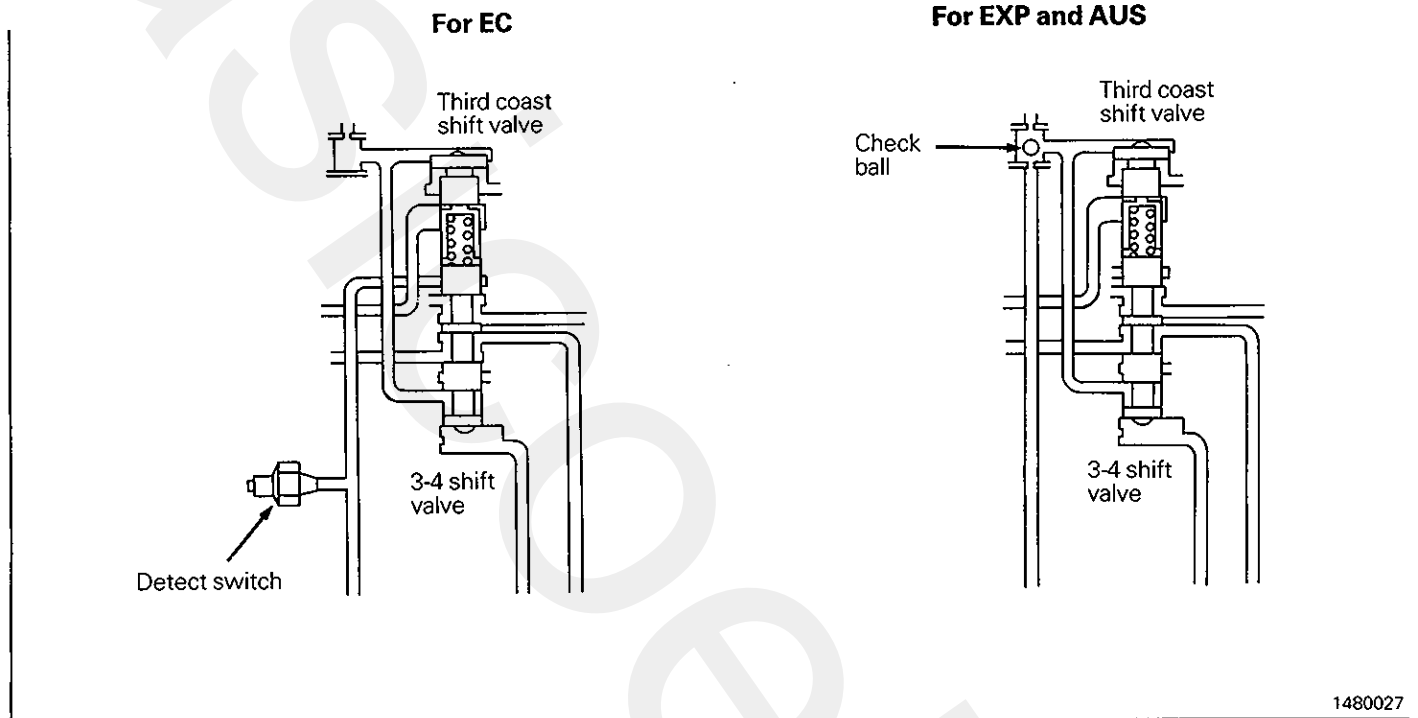

1480027



HYDRAULIC CONTROL SYSTEM with LOCKUP CLUTCH

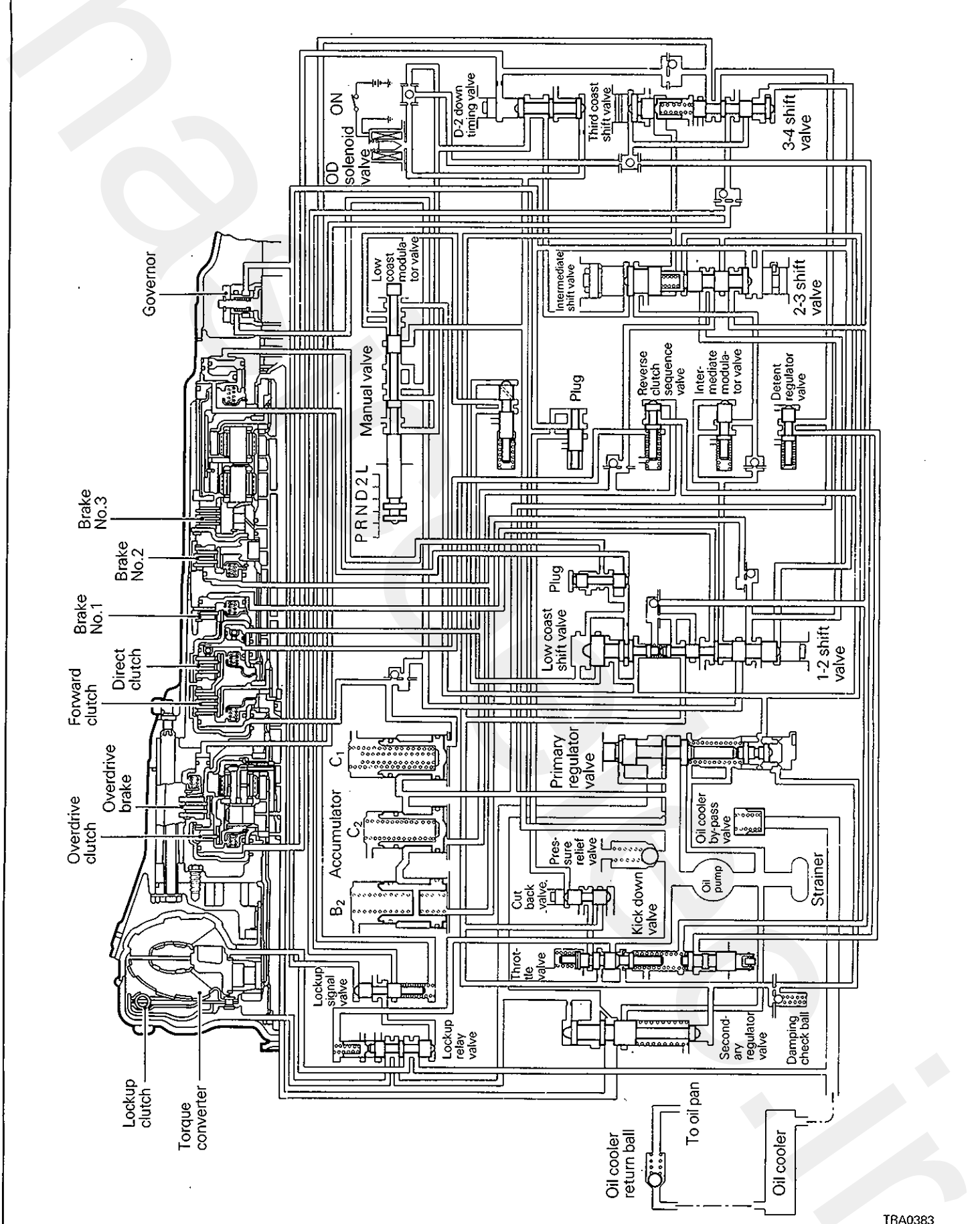

TRA0383

HYDRAULIC CONTROL SYSTEM without LOCKUP CLUTCH

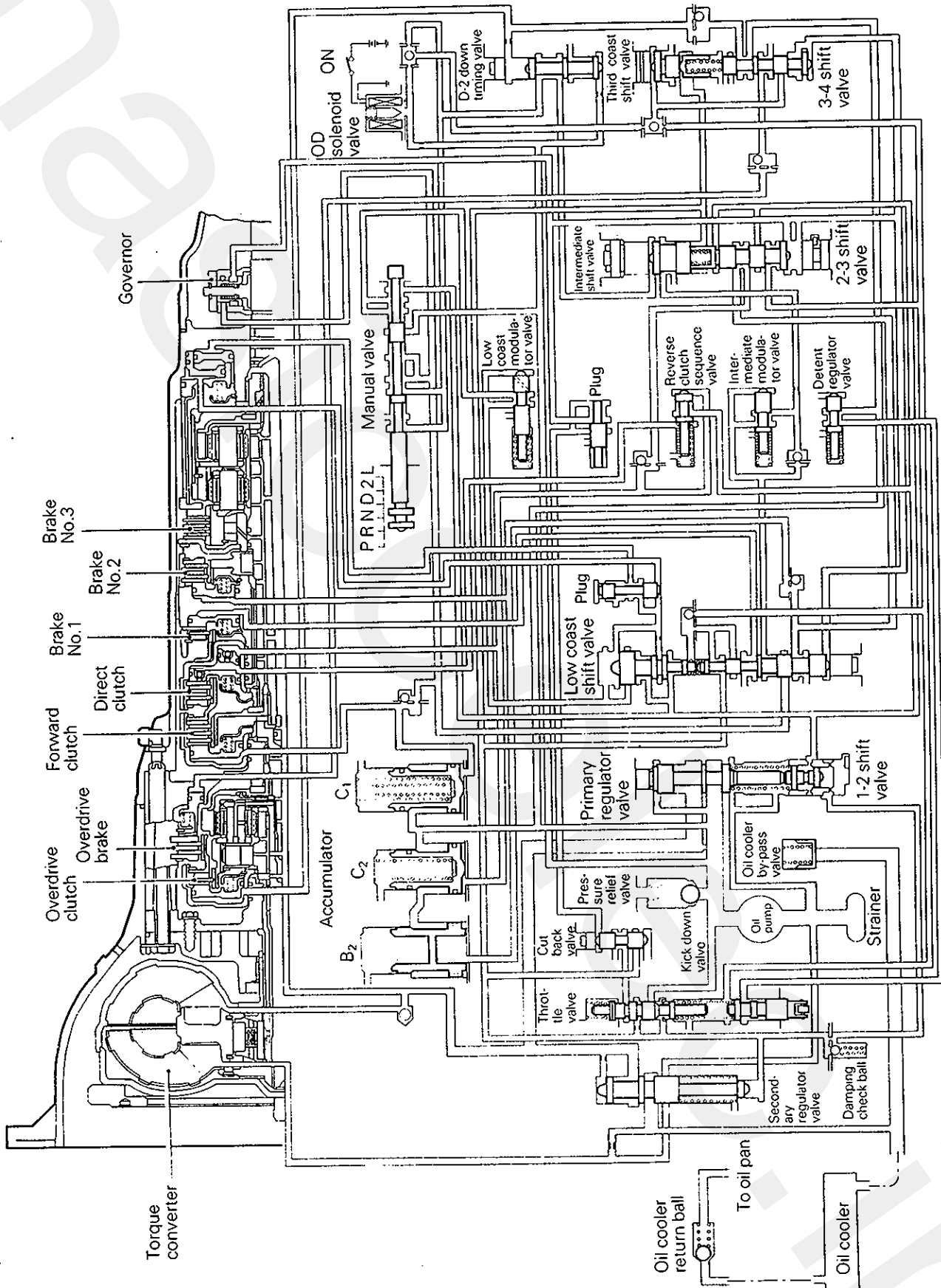

TRA0384

## 1. SPECIFICATIONS

## TRANSMISSION MODEL TABLE – MODEL 1987

Transmission model	Gear ratio	Lockup clutch	Speedometer gear ratio	Vehicle model	Engine model
EC KM148-2-D2	C	–	27/8	L049G	4D56 Turbocharger
AUS AW372L-5-B2	A	X	22/6	P03V,P13V,P03W	4G63
AW372L-5-B3	A	X	20/6	P04W	4G64
KM148-2-CS1	C	–	26/8	L047G	4G54

## TRANSMISSION MODEL TABLE – MODEL 1988

Transmission model	Gear ratio	Lockup clutch	Speedometer gear ratio	Vehicle model	Engine model
EC KM148-2-E1	C	–	26/8	L044G	4D56 Turbocharger
KM148-2-E2	C	–	27/8	L049G	4D56 Turbocharger
EXP AW372L-5-B2	A	X	22/6	P03W	4G63
KM148-2-C2	C	–	27/8	L047G	4G54
KM148-2-C3	C	–	25/8	L047G	4G54
AUS AW372L-5-B2	A	X	22/6	P03V,P13V,P03W	4G63
AW372L-5-B3	A	X	20/6	P04W	4G64
KM148-2-CS2	C	–	27/8	L047G	4G54

## TRANSMISSION MODEL TABLE – MODEL 1989

Transmission model	Gear ratio	Lockup clutch	Speedometer gear ratio	Vehicle model	Engine model
EC KM148-6-E1	D	X	26/8	L044G	4D56 with turbocharger and Intercooler
KM148-6-E2	D	X	27/8	L049G	4D56 with turbocharger and Intercooler
KM148-6-G1	D	–	26/8	L146G	6G72
EXP AW372L-5-B6	A	X	21/6	P03W	4G63
KM148-3-C2	D	–	27/8	L047G	4G54
KM148-3-C3	D	–	25/8	L047G	4G54
KM148-6-F1	D	–	26/8	L146G	6G72
AUS AW372L-5-B2	A	X	22/6	P03V,P13V,P03W	4G63
AW372L-5-B3	A	X	20/6	P04W	4G64
KM148-6-FS1	D	–	26/8	L146G	6G72

## TRANSMISSION MODEL TABLE – MODEL 1990

Transmission model	Gear ratio	Lockup clutch	Speedometer gear ratio	Vehicle model	Engine model
EC V4AW2-1-QFP	D	X	26/8	L144G	4D56 with turbocharger and Intercooler
V4AW2-1-QGP	D	X	27/8	L149G	4D56 with turbocharger and Intercooler
V4AW2-1-LFP	E	X	26/8	L146G	6G72
EXP R4AW2-2-EG	B	X	21/6	P03W	4G63
V4AW2-1-JG	D	–	27/8	L047G	4G54
V4AW2-1-JE	D	–	25/8	L047G	4G54
V4AW2-1-LF	E	X	26/8	L146G	6G72
AUS R4AW2-2-EH	B	X	22/6	P03V,P13V,P03W	4G63
R4AW2-2-GF	B	X	20/6	P04W	4G64
V4AW2-1-LFS	E	X	26/8	L146G	6G72

## TRANSMISSION MODEL TABLE – MODEL 1991

Transmission model	Gear ratio	Lockup clutch	VCU	Speedometer gear ratio	Vehicle model	Engine model
EC V4AW2-3-QGP	D	X	X	27/8	V44W	4D56 with turbocharger and Intercooler
V4AW2-3-QGPL	D	X	X	27/8	V44W	4D56 with turbocharger and Intercooler
V4AW2-3-OHP	D	X	X	28/8	V44W	4D56 with turbocharger and Intercooler
V4AW2-3-OHPL	D	X	X	28/8	V44W	4D56 with turbocharger and Intercooler
V4AW2-3-LFP	E	X	X	26/8	V23W,V43W	6G72
V4AW2-3-LFPL	E	X	X	26/8	V23W,V23C,V43W	6G72
EXP R4AW2-2-EG	B	X	–	21/6	P03W	4G63
R4AW2-2-EH	B	X	–	22/6	P03W	4G63
R4AW2-2-PF	B	X	–	20/6	P05W	4D56
V4AW2-1-JG	D	–	–	27/8	L047G	4G54
V4AW2-1-JE	D	–	–	25/8	L047G	4G54
V4AW2-1-LF	E	X	–	26/8	L146G	6G72
AUS R4AW2-2-EH	B	X	–	22/6	P03V,P13V	4G63
R4AW2-2-PH	B	X	–	22/6	P05V,P15V	4D56
R4AW2-2-GF	B	X	–	20/6	P04W	4G64
V4AW2-3-LF	E	X	X	26/8	V43W	6G72

**TRANSMISSION MODEL TABLE – MODEL 1992**

Transmission model	Gear ratio	Lockup clutch	VCU	Speedometer gear ratio	Vehicle model	Engine model
EC R4AW2-2-EH	B	X	–	22/6	P03W	4G63
EXP V4AW2-3-JGTL	D	–	–	27/8	V32W	4G54
V4AW2-3-JETL	D	–	–	25/8	V32W	4G54
V4AW2-3-LFL	E	X	X	26/8	V43W	6G72
AUS R4AW2-2-EH	B	X	–	22/6	P03V,P13V	4G63
R4AW2-2-PH	B	X	–	22/6	P05V,P15V	4D56
R4AW2-2-GF	B	X	–	20/6	P04W	4G64
R4AW2-2-GH	B	X	–	22/6	P14V	4G64

**TRANSMISSION MODEL TABLE – MODEL 1993**

Transmission model	Gear ratio	Lockup clutch	VCU	Speedometer gear ratio	Vehicle model	Engine model
EC R4AW2-2-EHX	B	X	–	22/6	P03W	4G63
V4AW2-3-QGP	D	X	X	27/8	V44W	4D56 with turbocharger and Intercooler
V4AW2-3-QGPL	D	X	X	27/8	V44W	4D56 with turbocharger and Intercooler
V4AW2-3-LFP	E	X	X	26/8	V23W,V43W	6G72
V4AW2-3-LFPL	E	X	X	26/8	V23W,V23C,V43W	6G72
EXP R4AW2-2-EG	B	X	–	21/6	P03W	4G63
R4AW2-2-EHX	B	X	–	22/6	P03W	4G63
R4AW2-2-GF	B	X	–	20/6	P04W	4G64
R4AW2-2-PF	B	X	–	20/6	P05W	4D56
V4AW2-3-LE	E	X	X	25/8	V43W	6G72
V4AW2-2-QH	D	X	X	28/8	V44W	4D56 with turbocharger and Intercooler
V4AW2-2-QHL	D	X	X	28/8	V44W	4D56 with turbocharger and Intercooler
V4AW2-3-JGTL	D	–	–	27/8	V32W	4G54
V4AW2-3-JETL	D	–	–	25/8	V32W	4G54
V4AW2-3-LEL	E	X	X	25/8	V23W,V25W,V43W	6G72
AUS R4AW2-2-EHX	B	X	–	22/6	P03V,P13V	4G63
R4AW2-2-PH	B	X	–	22/6	P05V,P15V	4D56
R4AW2-2-GF	B	X	–	20/6	P04W	4G64
V4AW2-3-LF	E	X	X	26/8	V43W	6G72

## TRANSMISSION MODEL TABLE – MODEL 1994

	Transmission model	Gear ratio	Lockup clutch	VCU	Speedometer gear ratio	Vehicle model	Engine model
EC	R4AW2-2-EHX	B	X	–	22/6	P03W	4G63
	V4AW2-7-LFP	E	X	X	26/8	V23W,V43W	6G72
	V4AW2-7-LFPL	E	X	X	26/8	V23W,V23C,V43W	6G72
EXP	R4AW2-2-EG	B	X	–	21/6	P03W	4G63
	R4AW2-2-EHX	B	X	–	22/6	P03W	4G63
	R4AW2-2-GF	B	X	–	20/6	P04W	4G64
	R4AW2-2-PF	B	X	–	20/6	P05W	4D56
	V4AW2-7-JGTL	D	–	–	27/8	V32W	4G54
	V4AW2-7-JETL	D	–	–	25/8	V32W	4G54
	V4AW2-7-LEL	E	X	X	25/8	V23W,V25W,V43W	6G72
AUS	R4AW2-2-EHX	B	X	–	22/6	P03V,P13V	4G63
	R4AW2-2-PH	B	X	–	22/6	P05V,P15V	4D56
	R4AW2-2-GF	B	X	–	20/6	P04W	4G64
	V4AW2-7-LE	E	X	X	25/8	V23W	6G72
	V4AW2-7-LF	E	X	X	26/8	V43W	6G72

## TRANSMISSION MODEL TABLE – MODEL 1995

	Transmission model	Gear ratio	Lockup clutch	VCU	Speedometer gear ratio	Vehicle model	Engine model
EC	R4AW2-5-FHP	B	X	–	22/6	PA3W	4G63
	R4AW2-5-GGP	B	X	–	21/6	PA4W	4G64
EXP	R4AW2-5-EI	B	X	–	23/6	PA3W	4G63
	R4AW2-5-PF	B	X	–	20/6	PA5W	4D56 with turbocharger
	R4AW2-5-GH	B	X	–	22/6	PA4W	4G64
	V4AW2-7-JGTL	D	–	–	27/8	V32W	4G54
	V4AW2-7-JETL	D	–	–	25/8	V32W	4G54
	V4AW2-7-QH	D	X	X	28/8	V44W	4D56 with turbocharger and Intercooler
	V4AW2-7-QHL	D	X	X	26/8	V44W	4D56 with turbocharger and Intercooler
	V4AW2-7-LEL	E	X	X	25/8	V43W	6G72
	V4AW2-7-LF	E	X	X	26/8	V43W	6G72
	V4AW2-7-LFL	E	X	X	26/8	V43W	6G72
AUS	R4AW2-5-EH	B	X	–	22/6	PA3W	4G63
	R4AW2-5-GG	B	X	–	21/6	PA4W	4G64
	R4AW2-5-GH	B	X	–	22/6	PB4V	4G64
	R4AW2-8-EI	B	X	–	23/6	P03V	4G63
	R4AW2-8-GH	B	X	–	22/6	P14V	4G64
	R4AW2-8-PF	B	X	–	20/6	P05V,P15V	4D56
	V4AW2-7-LE	E	X	X	25/8	V23W,V43W	6G72
	V4AW2-7-LF	E	X	X	26/8	V43W	6G72

**TRANSMISSION MODEL TABLE – MODEL 1996**

Transmission model	Gear ratio	Lockup clutch	VCU	Speedometer gear ratio	Vehicle model	Engine model
EC R4AW2-5-FHP	B	×	–	22/6	PA3W	4G63
R4AW2-5-GGP	B	×	–	21/6	PA4W	4G64
EXP R4AW2-5-EG	B	×	–	21/6	P03W	4G63
R4AW2-5-EI	B	×	–	23/6	PA3W	4G63
R4AW2-5-GH	B	×	–	22/6	PA4W	4G64
R4AW2-5-PF	B	×	–	20/6	PA5W	4D56 with turbocharger
V4AW2-7-JETL	D	–	–	25/8	V32W	4G63
V4AW2-7-JGTL	D	–	–	27/8	V32W	4G63
V4AW2-7-LEL	E	×	×	25/8	V23W	6G72
V4AW2-7-LF	E	×	×	26/8	V43W	6G72
V4AW2-7-LFL	E	×	×	26/8	V23W, V33W, V43W	6G72
V4AW2-7-QHU	D	×	×	28/8	V44W	4D56 with turbocharger and intercooler
AUS R4AW2-2-EHX	B	×	–	22/6	P03W	4G63
R4AW2-5-EH	B	×	–	22/6	PA3W	4G63
R4AW2-5-GG	B	×	–	21/6	PA4W	4G64
R4AW2-5-GH	B	×	–	22/6	PB4V	4G64
R4AW2-8-EI	B	×	–	23/6	P03W	4G63
R4AW2-8-GH	B	×	–	22/6	P14V	4G64
R4AW2-8-PF	B	×	–	20/6	P05V, P15V	4D56
V4AW2-7-LE	E	×	×	25/8	V43W	6G72
V4AW2-7-LF	E	×	×	26/8	V23W	6G72

**TRANSMISSION MODEL TABLE – MODEL 1997**

Transmission model	Gear ratio	Lockup clutch	VCU	Speedometer gear ratio	Vehicle model	Engine model
EC R4AW2-5-FHPC	B	×	–	22/6	PA3W	4G63
R4AW2-5-GGPC	B	×	–	21/6	PA4W	4G64
EXP V4AW2-2-LEL	E	×	×	25/8	V23W	6G72
V4AW2-2-AEL	E	×	×	25/8	V23W	6G72
R4AW2-5-EIC	B	×	–	23/6	PA3W	4G63
R4AW2-5-PFC	B	×	–	20/6	PA5W	4D56 with turbocharger and intercooler
R4AW2-5-GHC	B	×	–	22/6	PA4W	4G64
V4AW2-7-LEL	E	×	×	25/8	V33W, V43W	6G72
V4AW2-7-QHU	D	×	×	28/8	V44W	4D56 with turbocharger and intercooler
V4AW2-A-GGTL	D	×	–	27/8	V31W	4G64
V4AW2-A-GETL	D	×	–	25/8	V31W	4G64
AUS R4AW2-5-GHC	B	×	–	22/6	PB4V	4G64
R4AW2-5-EHC	B	×	–	22/6	PA3W	4G63
R4AW2-5-GGC	B	×	–	21/6	PA4W	4G64
V4AW2-7-LF	E	×	×	26/8	V23W	6G72

## TRANSMISSION MODEL TABLE – MODEL 1998

Transmission model	Gear ratio	Lockup clutch	VCU	Speedometer gear ratio	Vehicle model	Engine model
EC R4AW2-5-FHPC	B	×	–	22/6	PA3W	4G63
R4AW2-5-GGPC	B	×	–	21/6	PA4W	4G64
R4AW2-6-FHPC	B	×	–	22/6	K62T	4G63
V4AW2-6-QEBL	D	×	×	25/8	K74T	4D56 with turbocharger and intercooler
R4AW2-8-EI	B	×	–	23/6	PA4W	4G64
R4AW2-8-PF	B	×	–	20/6	PA4W	4G64
EXP R4AW2-5-EIC	B	×	–	23/6	PA3W	4G63
R4AW2-5-GHC	B	×	–	22/6	PA4W	4G64
V4AW2-7-LEL	E	×	×	25/8	V23W, V43W	6G72
V4AW2-7-QHU	D	×	×	28/8	V44W	4D56 with turbocharger and intercooler
V4AW2-A-GGTL	D	×	–	27/8	V31W	4G64
AUS R4AW2-5-GHC	B	×	–	22/6	PB4V	4G64
R4AW2-5-EHC	B	×	–	22/6	PA3W	4G63
R4AW2-5-GGC	B	×	–	21/6	PB4W	4G64
R4AW2-6-GFD	B	×	–	20/6	K65T	4G64
R4AW2-8-EID	B	×	–	23/6	P03V	4G63
R4AW2-8-GHD	B	×	–	22/6	P14V	4G64
R4AW2-8-FID	B	×	–	23/6	P03W	4G63



**TRANSMISSION MODEL TABLE – MODEL 1999**

Transmission model	Gear ratio	Lockup clutch	VCU	Speedometer gear ratio	Vehicle model	Engine model
EC R4AW2-5-FHPC	B	×	–	22/6	PA3W	4G63
R4AW2-5-GGPC	B	×	–	21/6	PA4W	4G64
R4AW2-6-FHPC	B	×	–	22/6	K62T	4G63
V4AW2-6-QEBL	D	×	×	25/8	K74T	4D56 with turbocharger and intercooler
R4AW2-8-EI	B	×	–	23/6	PA4W	4G64
R4AW2-8-PF	B	×	–	20/6	PA4W	4G64
EXP R4AW2-5-EIC	B	×	–	23/6	PA3W	4G63
R4AW2-5-GHC	B	×	–	22/6	PA4W	4G64
V4AW2-7-LEL	E	×	×	25/8	V23W, V43W	6G72
V4AW2-7-QHU	D	×	×	28/8	V44W	4D56 with turbocharger and intercooler
V4AW2-A-GGTL	D	×	–	27/8	V31W	4G64
V4AW2-A-GETL	D	×	–	25/8	V31W	4G64
AUS R4AW2-5-FJC	B	×	–	24/6	PB3V	4G63
R4AW2-5-GHC	B	×	–	22/6	PB4W	4G64
R4AW2-5-FHC	B	×	–	22/6	PA3W	4G63
R4AW2-5-GGC	B	×	–	21/6	PB4W	4G64
R4AW2-6-GFD	B	×	–	20/6	K65T	4G64
R4AW2-8-EID	B	×	–	23/6	P03V	4G63
R4AW2-8-GHD	B	×	–	22/6	P14V, P04W	4G64
R4AW2-8-FID	B	×	–	23/6	P03W	4G63

**TRANSMISSION MODEL TABLE – MODEL 2000**

Transmission model	Gear ratio	Lockup clutch	VCU	Speedometer gear ratio	Vehicle model	Engine model
EC R4AW2-6-FHPD	B	×	–	22/6	K62T	4G63
V4AW2-6-QEHL	D	×	×	25/8	K74T	4D56 with turbocharger and intercooler
EXP V4AW2-7-LFTL	E	×	–	26/8	V13W, V33V	6G72
V4AW2-7-LDTL	E	×	–	24/8	V13W, V33V	6G72
V4AW2-7-LFL	E	×	×	26/8	V23W, V43W	6G72
V4AW2-7-QHU	D	×	×	28/8	V44W	4D56 with turbocharger and intercooler
R4AW2-8-EHD	B	×	–	22/6	P03W	4G63
R4AW2-8-EID	B	×	–	23/6	P03W	4G63
AUS R4AW2-6-GFD	B	×	–	20/6	K65T	4G64
R4AW2-5-GHC	B	×	–	22/6	PB4V	4G64
R4AW2-5-FHC	B	×	–	22/6	PA3W	4G63
R4AW2-5-GGC	B	×	–	21/6	PB4W	4G64
R4AW2-8-EID	B	×	–	23/6	P03V	4G63
R4AW2-8-GHD	B	×	–	22/6	P14V	4G64
R4AW2-8-FID	B	×	–	23/6	P03W	4G63

## TRANSMISSION MODEL TABLE - MODEL 2001

Transmission model	Gear ratio	Lockup clutch	VCU	Speedometer gear ratio	Vehicle model	Engine model
EC R4AW2-6-FHPD	B	×	-	22/6	K62T	4G63
V4AW2-6-QEHL	D	×	×	25/8	K74T	4D56 with turbocharger and intercooler

## GEAR RATIO TABLE

	Gear ratio	A	B	C	D	E
Transmission	1st	2.826	2.826	2.826	2.826	2.826
	2nd	1.493	1.493	1.493	1.493	1.493
	3rd	1.000	1.000	1.000	1.000	1.000
	4th	0.688	0.730	0.688	0.688	0.730
	Reverse	2.703	2.703	2.703	2.703	2.703
Transfer	High	-	-	1.000	1.000	1.000
	Low	-	-	1.944	1.925	1.925

**SERVICE SPECIFICATIONS**

mm (in.)

	Standard	Limit
<b>Transmission</b>		
Input shaft end play .....	0.3 – 0.9 (0.012– 0.035)	
Oil pump side clearance .....	0.02 – 0.05 (0.0008 – 0.0020)	0.1 (0.004)
Overdrive clutch piston stroke (C <sub>0</sub> ) .....	2 discs .....	1.56 – 2.53 (0.061 – 0.100)
	(Without cushion plate)	
	2 discs .....	1.92 – 2.64 (0.076 – 0.104)
	(With cushion plate)	
	1 disc .....	1.77 – 2.58 (0.0697 – 0.1016)
	(With cushion plate)	
	<L300 (4G64), L400 (4G64) MODEL 1995>	
	1 disc .....	1.73 – 2.62 (0.0681 – 0.1031)
	(With cushion plate)	
	<L300 (4G64), L400 (4G64) MODEL 1996>	
Forward clutch piston stroke (C <sub>1</sub> ) .....	4 discs .....	1.32 – 2.66 (0.052 – 0.105)
	5 discs .....	1.43 – 2.93 (0.059 – 0.115)
Direct clutch piston stroke (C <sub>2</sub> ) .....	Double piston .....	1.06 – 2.14 (0.042 – 0.084)
	Single piston .....	0.91 – 1.99 (0.036 – 0.078)
Overdrive brake clearance (B <sub>0</sub> ) .....	2 discs .....	0.56 – 1.92 (0.022 – 0.076)
	3 discs .....	0.65 – 2.21 (0.026 – 0.087)
No. 1 brake piston stroke (B <sub>1</sub> ) .....		0.80 – 1.73 (0.031 – 0.068)
No. 2 brake piston stroke (B <sub>2</sub> ) .....		1.01 – 2.25 (0.040 – 0.089)
No. 3 brake clearance (B <sub>3</sub> ) .....		0.61 – 2.64 (0.024 – 0.104)
Stator support bushing bore (Front) .....	21.501 – 21.527 (0.8465 – 0.8475)	21.577 (0.8495)
Stator support bushing bore (Rear) .....	23.025 – 23.051 (0.9065 – 0.9075)	23.101 (0.9095)
Oil pump body bushing bore .....	38.113 – 38.138 (1.5005 – 1.5015)	38.188 (1.5035)
Overdrive sun gear bushing bore (Front and Rear) .....	23.062 – 23.088 (0.9080 – 0.9090)	23.188 (0.9109)
Overdrive input shaft bushing .....	11.200 – 11.221 (0.4409 – 0.4418)	11.271 (0.4437)
Sun gear bushing bore (Front and Rear) .....	21.501 – 21.527 (0.8465 – 0.8475)	21.577 (0.8495)
Center support bushing bore .....	36.386 – 36.411 (1.4325 – 1.4335)	36.461 (1.4355)
Transmission case bushing bore .....	38.113 – 38.138 (1.5005 – 1.5015)	38.188 (1.5035)
Output shaft bushing .....	18.001 – 18.026 (0.7087 – 0.7097)	18.076 (0.7117)
Extension housing bushing bore .....	39.636 – 39.661 (1.5605 – 1.5615)	39.711 (1.5634)

mm (in.)

	Standard	Limit
<b>Transfer</b>		
H-L clutch hub end play .....	0 – 0.08 (0 – 0.0031)	
Input gear bearing end play .....	0 – 0.06 (0 – 0.0024)	
Input gear end play .....	0 – 0.06 (0 – 0.0024)	
Rear output shaft end play .....	0 – 0.1 (0 – 0.0039)	
Center differential end play (SUPER SELECT 4WD only) <Up to November 1992> .....	0.025 – 0.150 (0.00098 – 0.00591)	
Differential lock hub end play (SUPER SELECT 4WD only) .....	0 – 0.08 (0 – 0.0031)	
2-4WD synchronizer hub end play (SUPER SELECT 4WD only) .....	0 – 0.08 (0 – 0.0031)	
Rear output shaft bearing end play (SUPER SELECT 4WD only) .....	0 – 0.08 (0 – 0.0031)	
Clearance between outer synchronizer ring back side and drive sprocket (SUPER SELECT 4WD only) .....		0.3 (0.0118)

**VALVE BODY SPRING IDENTIFICATION**

mm (in.)

	Free height	Outside diameter	Number of loops	Wire diameter	Identification color
<b>Upper front valve body</b>					
Throttle valve spring .....	21.94 (0.864)	8.58 (0.338)	8	0.71 (0.028)	None
<b>Kickdown valve spring</b>					
4G54, 4G63-CARB .....	43.44 (1.710)	10.87 (0.428)	15.5	1.2 (0.047)	Orange
4G63-MPI, 4G64, 6G72 .....	39.76 (1.565)	10.83 (0.426)	11.5	1.2 (0.047)	Purple
4D56 .....	40.46 (1.593)	10.82 (0.426)	17.5	1.2 (0.047)	Blue
Secondary regulator valve spring .....	71.27 (2.806)	17.43 (0.686)	15	1.93 (0.076)	Green
<b>Upper rear valve body</b>					
Intermediate modulator valve spring .....	35.43 (1.395)	8.80 (0.346)	14.4	0.9 (0.035)	Red
<b>Reverse clutch sequence valve spring</b>					
4G54 .....	33.72 (1.327)	9.32 (0.367)	13	1.32 (0.052)	Yellow
4G63, 4G64, 6G72, 4D56 .....	37.55 (1.478)	9.2 (0.362)	14	1.2 (0.047)	Red
Low coast modulator valve spring .....	42.35 (1.667)	9.24 (0.364)	15	0.084 (0.033)	None
2-3 shift valve spring .....	35.10 (1.382)	8.96 (0.353)	12.5	0.76 (0.030)	White
<b>Detent regulator valve spring</b>					
4G54 .....	30.43 (1.198)	8.90 (0.350)	13	0.9 (0.035)	Green
4G63, 4G64, 6G72 .....	31.39 (1.236)	8.85 (0.348)	13.5	0.9 (0.035)	Orange
4D56 for EC*1, *2, 4D56*3 .....	26.44 (1.041)	8.85 (0.348)	13.5	0.9 (0.035)	Purple
4D56 for EXP, AUS*1, *2 .....	25.26 (0.994)	8.85 (0.348)	13.5	0.9 (0.035)	White
4D56 with turbocharger and intercooler <MODEL 1996> .....	25.26 (0.994)	8.85 (0.348)	13.5	0.9 (0.035)	White
(When replacing the spring, be sure to install the same one as currently installed.)	26.00 (1.024)	8.94 (0.352)	13.0	0.9 (0.035)	Pink
	26.44 (1.041)	8.85 (0.348)	13.5	0.9 (0.035)	Yellowish green

	Free height	Outside diameter	Number of loops	Wire diameter	Identification color
mm (in.)					
Lower valve body					
1-2 shift valve spring .....	34.62 (1.363)	7.56 (0.298)	13	0.56 (0.022)	None
3-4 shift valve spring					
4G54, 6G72, 4G63, 4G64 .....	35.18 (1.385)	10.6 (0.417)	14.5	1.10 (0.043)	Green
4D56 for EC*2, 4D56*1 .....	40.08 (1.578)	10.5 (0.413)	13	1.10 (0.043)	Light green
4D56 for EXP, AUS*2 .....	36.28 (1.428)	10.6 (0.417)	14.5	1.10 (0.043)	Red
4D56*3 .....	33.65 (1.325)	10.6 (0.417)	14.5	1.10 (0.043)	Orange
Pressure relief valve spring .....	32.14 (1.265)	13.14 (0.517)	9	2.03 (0.080)	None
Oil cooler bypass valve spring .....	28.9 (1.138)	13.8 (0.543)	6.5	1.60 (0.063)	Orange
Primary regulator valve spring					
4G54, 4G63*1, 4G64*1 .....	55.21 (2.174)	17.02 (0.670)	10.5	1.7 (0.067)	White
4G63*3, 4G64*4 .....	56.9 (2.240)	17.02 (0.670)	10.5	1.7 (0.067)	Yellow
4G64*5 .....	67.31 (2.650)	15.14 (0.596)	11.8	1.5 (0.059)	None
6G72 .....	59.59 (2.346)	17.02 (0.670)	10.5	1.7 (0.067)	Light blue
4D56 .....	54.12 (2.131)	17.02 (0.670)	10.5	1.7 (0.067)	Purple
Damping check valve spring .....	20.00 (0.787)	4.97 (0.196)	16	0.40 (0.016)	None
Lock-up signal valve spring					
4G63, 4G64 .....	45.31 (1.784)	9.6 (0.378)	15.7	1.00 (0.039)	White
6G72 .....	46.0 (1.811)	9.7 (0.382)	14.5	1.00 (0.039)	Yellow
4D56 .....	37.38 (1.472)	9.7 (0.382)	13.5	1.10 (0.043)	Purple
Lock-up relay valve spring .....	18.5 (0.728)	5.2 (0.205)	13	0.55 (0.022)	White

## NOTE

\*1: For L300

\*4: For L400 &lt;Up to MODEL 1995&gt;

\*2: For Pajero/Montero

\*5: For L400 &lt;From MODEL 1996&gt;

\*3: For L400

**ACCUMULATOR PISTON IDENTIFICATION**

	mm (in.)
	OD x Length
C <sub>1</sub> .....	31.8 x 49.5 (1.252 x 1.949)
C <sub>2</sub> .....	31.8 x 45.0 (1.252 x 1.772)
B <sub>2</sub> .....	34.8 x 48.5 (1.512 x 1.909)

**ACCUMULATOR PISTON SPRING IDENTIFICATION**

	Free height	Outside diameter	Number of loops	Wire diameter	Identification color
C <sub>1</sub> : Single spring 4G54, 4G63*1, 4D56*1,*2, 4G64*5 .....	64.68 (2.546)	17.5 (0.689)	22.5	2.0 (0.079)	None
C <sub>1</sub> : Twin spring					
No. 1					
4G63*3, 4G64, 6G72 .....	29.4 (1.157)	12.7 (0.5)	6.1	1.2 (0.047)	Pink
4D56*3 .....	30.5 (1.201)	13.45 (0.530)	7.0	1.1 (0.043)	None
No. 2					
4G63*3, 4G64, 6G72, 4D56*3 .....	57.2 (2.252)	17.5 (0.689)	17.3	1.9 (0.075)	Pink
C <sub>2</sub> : Single spring					
4D56*1, 4G63 (Carb) .....	58.96 (2.321)	16.5 (0.650)	13.5	2.5 (0.098)	Light blue
C <sub>2</sub> : Twin spring					
No. 1					
4G54 .....	32.73 (1.289)	14.8 (0.583)	8.23	1.3 (0.051)	Green
6G72, 4G64*5 .....	30.0 (1.181)	15.5 (0.610)	6.15	1.8 (0.071)	None
4G63 (MPI), 4D56*2,*3 .....	30.8 (1.213)	14.1 (0.555)	7.25	1.5 (0.059)	White
4G64*1,*2,*4 .....	32.2 (1.268)	14.7 (0.579)	6.5	1.6 (0.063)	Orange

	Free height	Outside diameter	Number of loops	Wire diameter	Identification color
mm (in.)					
No. 2					
4G54, 4G63 (MPI), 4D56*2, *3 .....	43.22 (1.702)	13.84 (0.545)	10.5	2.0 (0.079)	Red
6G72 .....	43.56 (1.715)	14.3 (0.563)	9.45	1.8 (0.071)	Blue
B <sub>2</sub> : Single spring					
4G54 .....	66.68 (2.625)	20.4 (0.803)	12	3.2 (0.126)	Light green
B <sub>2</sub> : Twin spring					
No. 1					
4G63 (MPI), 4G64, 4D56*1, *2, 6G72	35.13 (1.383)	16.16 (0.636)	6	1.3 (0.051)	Red
4D56*3 .....	48.14 (1.895)	19.32 (0.761)	8.75	2.1 (0.083)	White
No. 2					
4G63*1 .....	55.18 (2.172)	18.32 (0.721)	11	2.6 (0.102)	Light green
4G64*1, *2, *4, 4D56*2, 6G72 .....	55.18 (2.172)	22.39 (0.881)	11.75	2.9 (0.114)	Orange
4G64*5 .....	55.9 (2.201)	19.6 (0.777)	9.25	2.8 (0.110)	Light gray
4D56*1 .....	55.18 (2.172)	17.65 (0.695)	11	2.3 (0.091)	Light blue
4G63 (MPI) .....	50.68 (1.995)	19.15 (0.754)	9.25	3.0 (0.118)	Purple
4D56*3 .....	32.0 (1.260)	15.37 (0.605)	8	1.9 (0.075)	Yellow
Outer spring					
4G63 (Carb) .....	17.5 (0.689)	12.5 (0.492)	4	1.6 (0.063)	Red
Inner spring					
4G63 (Carb) .....	56.4 (2.220)	18.8 (0.740)	9.2	2.4 (0.094)	Green

## NOTE:

- In case of twin spring, No. 1 spring is valve body side one, while No. 2 spring is transmission case side one.
- \*1: For L300, \*2: For Pajero/Montero, \*3: For L400, \*4: For L400 <Up to MODEL 1995>, \*5: For L400 <From MODEL 1996>



**TORQUE SPECIFICATIONS**

	Torque		
	Nm	kgm	ft.lbs.
<b>Transmission</b>			
Converter housing installation bolts			
10 mm (0.39 in.) dia. bolt .....	35	3.5	25
12 mm (0.47 in.) dia. bolt .....	58	5.8	42
Oil pump assembly installation bolt .....	22	2.2	16
Oil pump body and cover-tightening bolt .....	7.5	0.75	5.4
Center support installation bolt .....	26	2.6	19
Adapter installation bolt .....	35	3.5	25
Cover plate installation screw .....	7.5	0.75	5.4
All bolts of valve body .....	5.5	0.55	4.0
Throttle cam installation bolt .....	7.5	0.75	5.4
Valve body assembly installation bolt .....	10	1.0	7.2
Oil screen installation bolt .....	5.5	0.55	4.0
Parking cam plate installation bolt .....	7.5	0.75	5.4
Oil pan installation bolt .....	4.5	0.45	3.3
Plug (for hydraulic test) .....	7.5	0.75	5.4
Oil pan drain plug .....	21	2.1	15
Overdrive solenoid valve installation bolt .....	13	1.3	9
Plug .....	13	1.3	9
Manual lever installation nut .....	16	1.6	12

	Torque		
	Nm	kgm	ft.lbs.
<b>Transfer</b>			
Transfer case installation bolt .....	36	3.6	26
Transfer case installation nut .....	36	3.6	26
Chain cover bolt .....	36	3.6	26
Side cover bolt .....	9	0.9	6.5
Rear cover bolt .....	36	3.6	26
Cover bolt .....	19	1.9	14
Control housing bolt .....	19	1.9	14
Oil filler plug .....	33	3.3	24
Drain plug .....	33	3.3	24
Select plug .....	33	3.3	24
Locking plate bolt .....	19	1.9	14
Rear output shaft lock nut .....	115	11.5	83
Speedometer sleeve clamp bolt .....	19	1.9	14
Seal plug (V4AW2-1 only) .....	36	3.6	26
4WD switch (V4AW2-1 only) .....	30	3.0	22
Control lever assembly to control housing .....	19	1.9	14
Pulse generator (V4AW2-1 only) .....	12	1.2	8.1
Pulse rotor (V4AW2-1 only) .....	8	0.8	5.8
Detection switch (V4AW2-3, 7 only) .....	36	3.6	26
Poppet plug (V4AW2-3, 7 only) .....	36	3.6	26
H-L shift rail plug (V4AW2-3, 7 only) .....	33	3.3	24
Oil dam cover (SUPER SELECT 4WD only) .....	9	0.9	6.5
Bearing retainer (SUPER SELECT 4WD only) .....	19	1.9	14
Dynamic damper (SUPER SELECT 4WD-6G72 engine only) .....	70	7.0	51
Center differential case .....	65	6.5	47

**SEALANTS**





	Specified sealants and adhesives	Quantity
<b>Transmission</b>		
Oil pump bolt (threads) .....	3M ATD Part No. 8660 or equivalent .....	As required
<b>Transfer</b>		
Adapter gasket (both sides) .....	Mitsubishi genuine sealant .....	As required
	Part No. MD997740 or equivalent	
Air breather (press-in circumference) – V4AW2-1 only .....	Mitsubishi genuine sealant .....	As required
	Part No. MD997740 or equivalent	
Chain cover gasket (both sides) – V4AW2-1 only .....	Mitsubishi genuine sealant .....	As required
	Part No. MD997740 or equivalent	
Rear cover gasket (both sides) – V4AW2-1 only .....	Mitsubishi genuine sealant .....	As required
	Part No. MD997740 or equivalent	
Cover gasket (both sides) – V4AW2-1 only .....	Mitsubishi genuine sealant .....	As required
	Part No. MD997740 or equivalent	
Chain cover – V4AW2-3, 7 only .....	Mitsubishi genuine sealant .....	As required
	Part No. MD997740 or equivalent	
Rear cover – V4AW2-3, 7 only .....	Mitsubishi genuine sealant .....	As required
	Part No. MD997740 or equivalent	
Cover – V4AW2-3, 7 only .....	Mitsubishi genuine sealant .....	As required
	Part No. MD997740 or equivalent	
Poppet plug – V4AW2-3, 7 only .....	3M ATD Part No. 8660 or equivalent .....	As required
Plug – V4AW2-3, 7 only .....	3M ATD Part No. 8660 or equivalent .....	As required
Bolt (threads) .....	3M STUD Locking 4170 or equivalent .....	As required

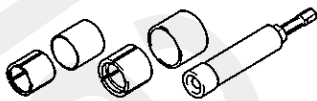

**ADJUSTMENT SNAP RINGS AND SPACERS**

Part name	Thickness mm (in.)	Identification symbol	Parts No.
<b>Transfer</b>			
Snap ring .....	2.30 (0.091)	–	MD704199
	(For adjustment of input gear bearing)		
	2.35 (0.093)	Red	MD704200
	2.40 (0.094)	White	MD704201
	2.45 (0.096)	Blue	MD704202
Snap ring .....	2.50 (0.098)	Green	MD704203
	(For adjustment of input gear assembly)		
	2.70 (0.106)	Purple	MD704204
	2.75 (0.108)	Pink	MD704205
	2.80 (0.110)	Yellow	MD704206
Snap ring .....	2.85 (0.112)	White	MD704207
	(For adjustment of H-L clutch hub)		
	2.90 (0.114)	Blue	MD704208
	2.14 (0.084)	–	MD704212
	2.21 (0.087)	Yellow	MD704213
Snap ring .....	2.28 (0.090)	White	MD704214
	2.35 (0.093)	Blue	MD704215
	2.42 (0.095)	Red	MD704216

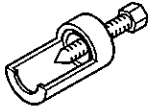
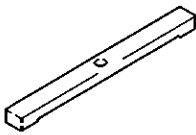
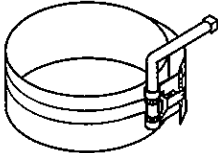
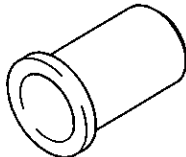
Part name	Thickness mm (in.)	Identification symbol	Parts No.
Spacer .....	0.84 (0.033)	84	MD734326
(For adjustment of rear output shaft)	0.93 (0.037)	93	MD734327
(For adjustment of center differential end play)	1.02 (0.040)	02	MD734328
<V4AW2-3, 7 (Super-select 4WD)>	1.11 (0.044)	11	MD734329
	1.20 (0.047)	20	MD734330
	1.29 (0.051)	29	MD734331
	1.38 (0.054)	38	MD734332
	1.47 (0.058)	47	MD734333
	1.56 (0.061)	56	MD734334
	1.65 (0.065)	65	MD734335
	1.74 (0.069)	74	MD734336
	1.83 (0.072)	83	MD734337
	1.92 (0.076)	92	MD734338
	2.01 (0.079)	01	MD734339
Snap ring .....	2.26 (0.089)	–	MD734311
V4AW2-3, 7 (Super-select 4WD)	2.33 (0.092)	Red	MD734312
(For adjustment of rear output shaft bearing end play)	2.40 (0.094)	White	MD734313
	2.47 (0.097)	Blue	MD734314
Snap ring .....	2.56 (0.101)	–	MD738393
V4AW2-3, 7 (Super-select 4WD)	2.63 (0.104)	Red	MD738394
(For adjustment of 2-4WD synchronizer hub end play)	2.70 (0.106)	White	MD738395
	2.77 (0.109)	Blue	MD738396
	2.84 (0.112)	Yellow	MD738397
Snap ring .....	2.56 (0.101)	–	MD738386
V4AW2-3, 7 (Super-select 4WD)	2.63 (0.104)	Red	MD738387
(For adjustment of differential lock hub end play)	2.70 (0.106)	White	MD738388
	2.77 (0.109)	Blue	MD738389
	2.84 (0.112)	Yellow	MD738390
	2.91 (0.115)	Green	MD738391
	2.98 (0.117)	Purple	MD738392



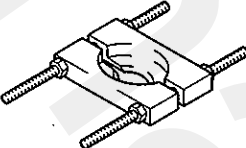
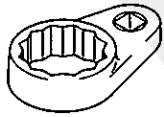
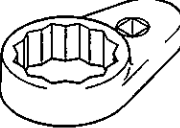

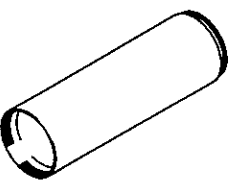
**2. SPECIAL TOOLS**

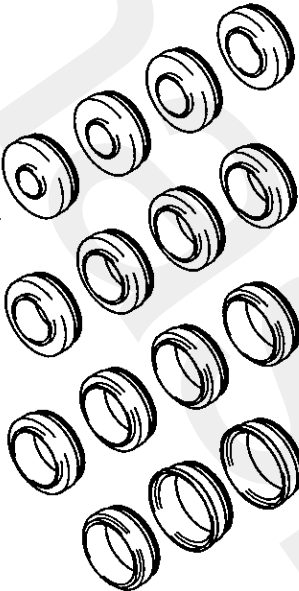
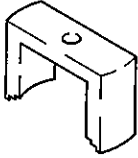
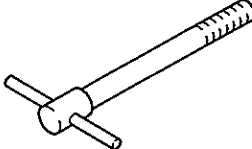
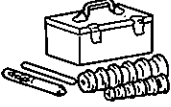
Tool	Number	Name	Use
	MD998192	Counter gear bearing puller	Installation of the bearing
	MD998211	Retainer	Disassembly and reassembly of No. 3 brake spring
	MD998212	Oil pump puller	Removal of oil pump
	MD998217	Gauge	Check of quality of assembly condition
	MD998335	Oil pump band	Assembly of oil pump
	MD998382	Oil seal installer	Installation of clutch hub (H-L)
	MD998412	Guide	Installation of oil pump

Tool	Number	Name	Use
	MD998801	Bearing remover	Removal of bearing
	MD998901	Bearing remover	Removal of bearing
	MD998809	Lock nut wrench (41)	Removal of the transfer rear output shaft lock nut
	MD998810	Lock nut wrench (46)	Removal and installation of rear output shaft lock nut
	MD998812	Installer cap	Installation of the bearing
	MD998813	Installer-100	Installation of the bearing
	MD998814	Installer-200	Installation of the bearing

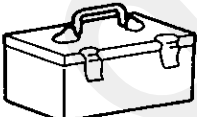
Tool	Number	Name	Use
	MD998815 MD998816 MD998817 MD998818 MD998819 MD998820 MD998821 MD998822 MD998823 MD998824 MD998825 MD998826 MD998827 MD998829 MD998830	Installer adapter	Installation of the bearing
	MD998903	Spring compressor	Disassembly and reassembly of clutch and brake
	MD998904	Bolt	Disassembly and reassembly of No. 3 brake spring
	MB990925	Bearing and oil seal installer set	Installation of the oil seal

## CONTENTS OF BEARING AND OIL SEAL INSTALLER SET MB990925

Set	Contents					
	Tool	Name	Tool No.	Diameter mm (in.)		
Bearing and oil seal installer set MB990925 		Installer adapter	MB990926	39 (1.535)		
			MB990927	45 (1.772)		
			MB990928	49.5 (1.949)		
			MB990929	51 (2.008)		
			MB990930	54 (2.126)		
			MB990931	57 (2.244)		
			MB990932	61 (2.402)		
			MB990933	63.5 (2.500)		
			MB990934	67.5 (2.657)		
			MB990935	71.5 (2.815)		
			MB990936	75.5 (2.972)		
			MB990937	79 (3.110)		
				Installer bar	MB990938	–
				Brass bar	MB990939	–



### 3. TRANSMISSION

#### DISASSEMBLY

- (1) Prior to disassembling any transmission and transfer assemblies, plug all openings and thoroughly clean exterior of the unit, preferably by steam.
- (2) Remove the torque converter.
- (3) Remove the transfer subassembly from transmission subassembly.
- (4) Place the transmission subassembly on a bench with the oil pan down.

#### Caution

- **Do not place the assembly with the oil pan up before the oil pan is removed. This is necessary to prevent foreign matter in the oil pan from entering the valve body.**

- (5) Remove the O.D. solenoid valve and the detect switch (EC only).
- (6) Remove the extension housing and gasket (2WD).

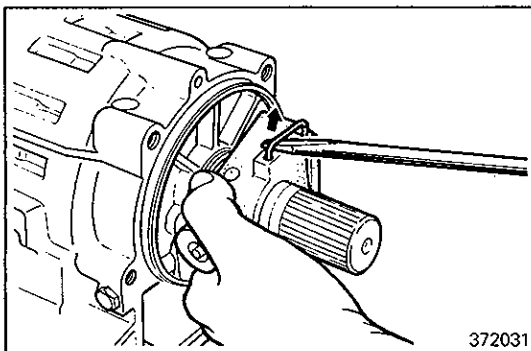
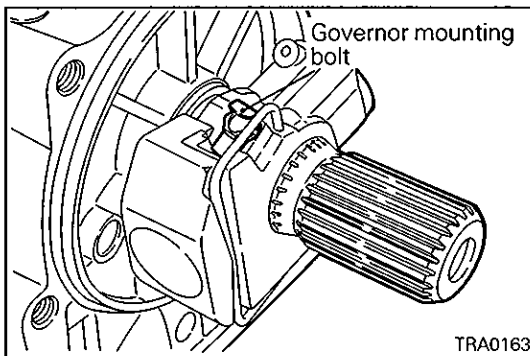
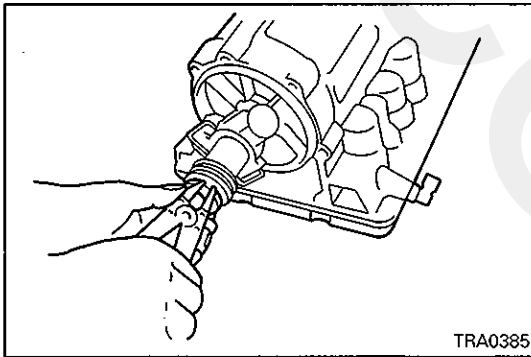
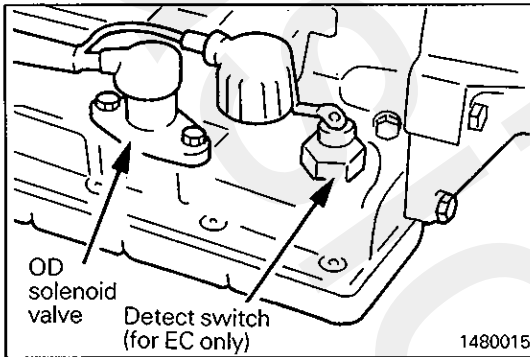

- (7) Remove the snap ring and speedometer drive gear (2WD).

- (8) Remove the adapter and gasket, and remove the oil seal from the adapter (4WD).
- (9) Remove the governor mounting bolt.

- (10) Lift up the governor retaining ring lightly by a screwdriver and remove the governor assembly from the output shaft.

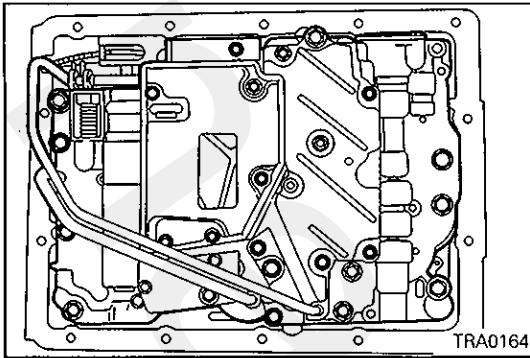

- (11) With the oil pan down, remove the oil pan bolts and then remove the oil pan and gasket.
- (12) Place the assembly with the valve body up.
- (13) Remove the oil pipe, prying with a screwdriver and using care not to cause deformation.
- (14) Remove the oil screen and spacer.

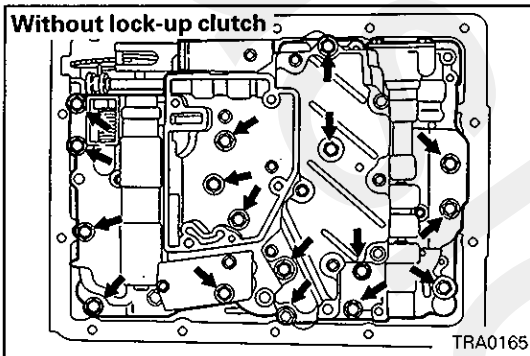

- (15) Remove 17 bolts attaching the valve body assembly.

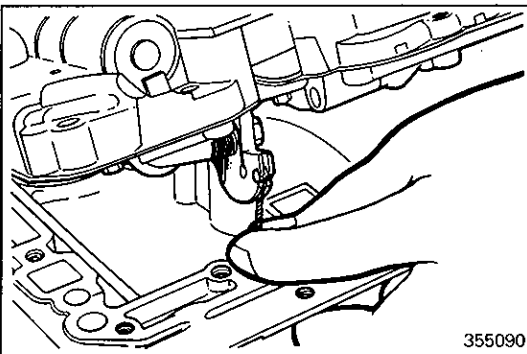
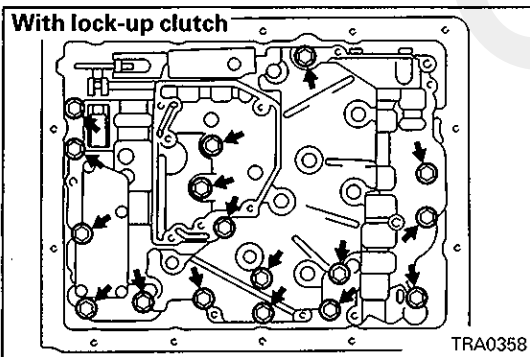

- (16) Raise the valve body assembly slowly and remove the throttle inner cable from the throttle cam. Then, remove the valve body assembly.

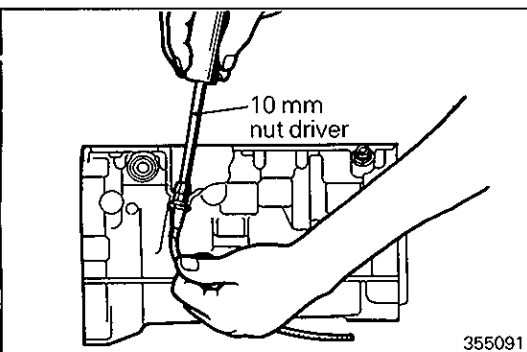

- (17) Push the throttle cable adapter to disconnect the throttle cable from the case.

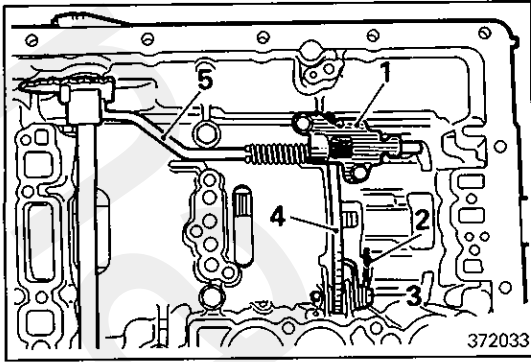

(18) Remove the plate 1 and parking pawl torsion spring 2. Then, pull out pivot pin 3 and remove parking pawl 4. Remove parking rod 5 from the manual valve detent lever.

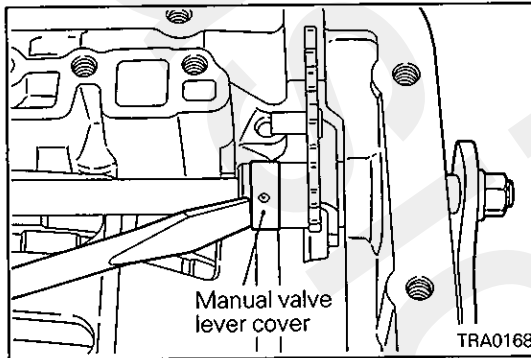

(19) Using a screwdriver, move the manual valve lever cover.

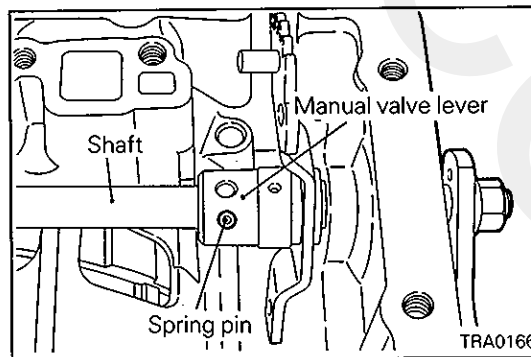

(20) Drive out spring pin, and then remove shaft and manual valve lever.  
 (21) Remove the oil seal from the manual valve shaft using a screwdriver. When installing the oil seal, do so evenly.

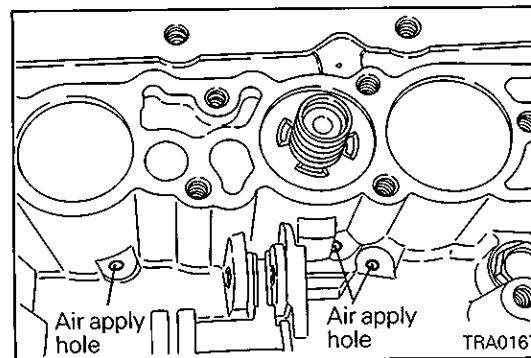

(22) Remove the accumulator piston by blowing air from the illustrated position.

**Caution**

- Use care as the piston and fluid pops and gushes out. Pistons for B<sub>2</sub>, C<sub>2</sub>, and C<sub>1</sub> have been installed from the front to rear in the order shown. Store the removed pistons and springs arranged in this order.

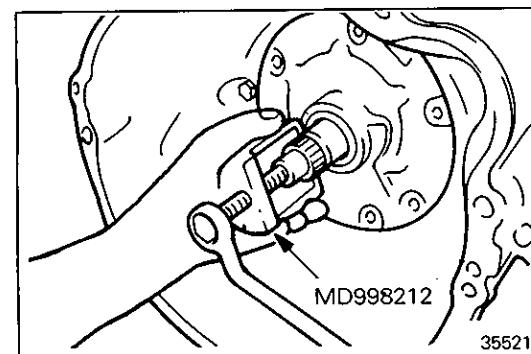

(23) Remove the oil pump attaching bolts.  
 (24) Remove the oil pump by using the special tool.  
 (25) Remove the converter housing attaching bolts.  
 (26) Holding the O.D. input shaft by hand, remove the converter housing.

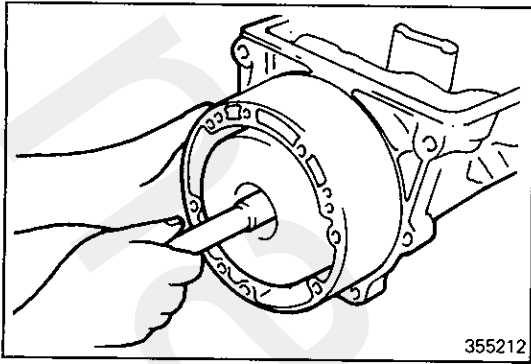

- (27) Remove the O.D. input shaft, planetary gear and O.D. clutch assembly from the O.D. case.
- (28) Separate the O.D. clutch from the O.D. planetary gear.

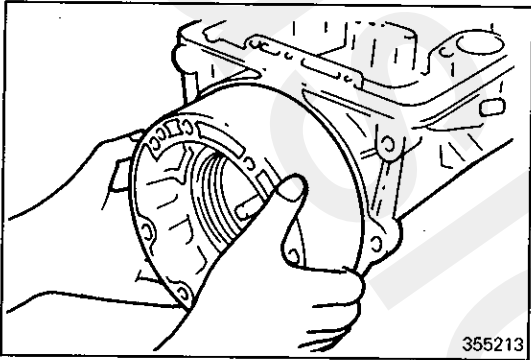

- (29) Remove the O.D. case assembly.

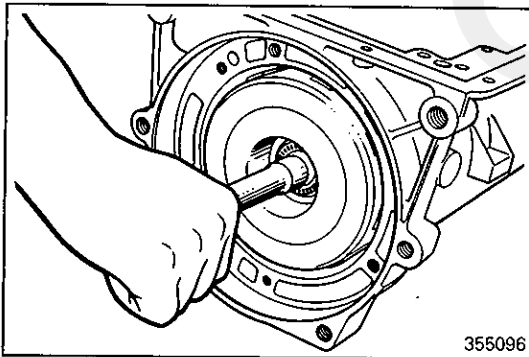

- (30) Remove the forward clutch assembly.

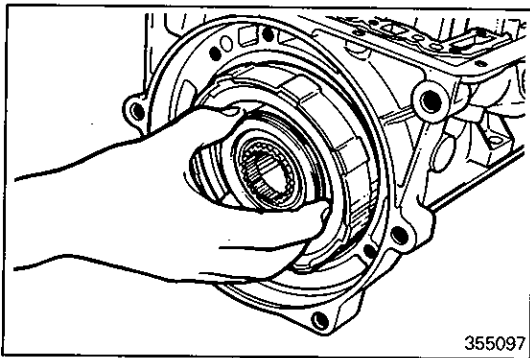

- (31) Remove the direct clutch assembly.

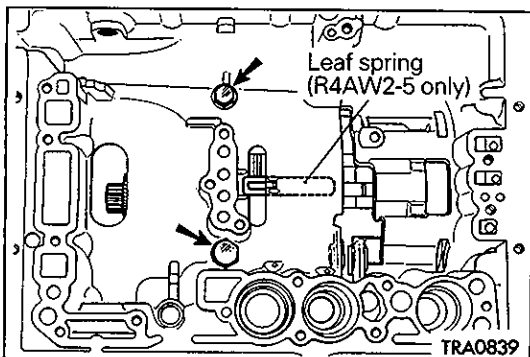

- (32) Remove the two center support attaching bolts.
- (33) Remove the leaf spring. <R4AW2-5>

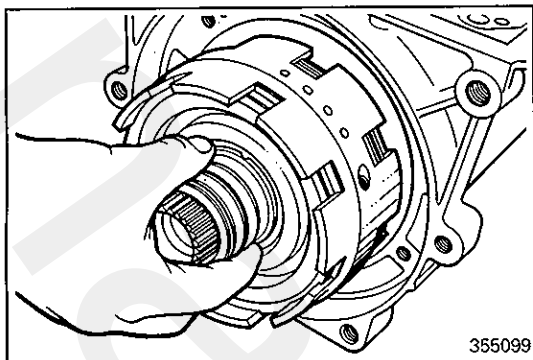

(34) Remove the center support and sun gear assembly together from the case.

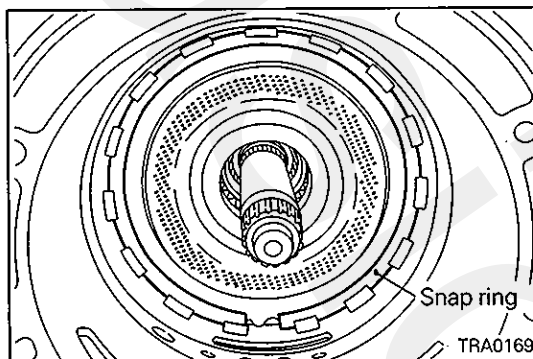

(35) Remove the snap ring from the front planetary carrier by using a screwdriver.

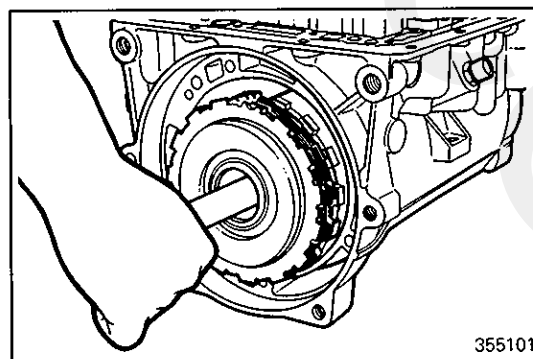

(36) Holding the intermediate shaft, remove the carrier assembly from the case.

(37) Remove the No. 3 brake tube.

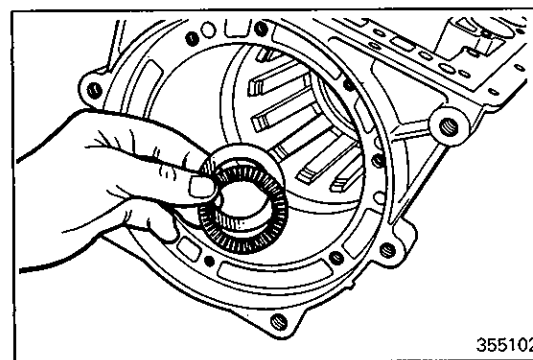

(38) Remove the output shaft thrust bearing and race from the case.

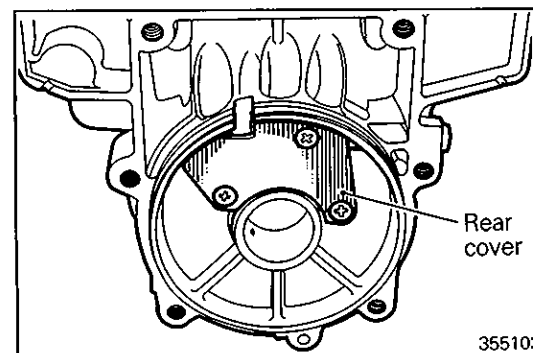

(39) Remove the rear cover and rear cover gasket.

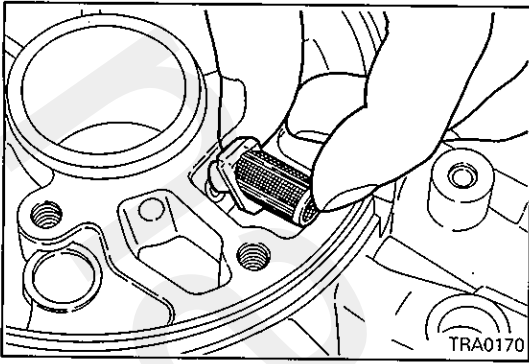

(40) Remove the filter.

**REASSEMBLY**

(1) Place the transmission case on a cylinder as illustrated. Use of a cylinder measuring 300 mm (12 in.) long and 180 mm (7 in.) in diameter is recommended. Place shock absorbing material between the case and the cylinder to prevent damage to the case.

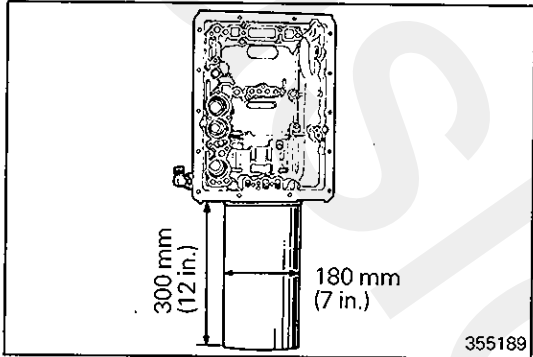

(2) Install output shaft thrust bearing race #20 and thrust bearing #19 in the case.

**Caution**

- When installing the thrust bearing and race, note their direction, referring to the illustration.

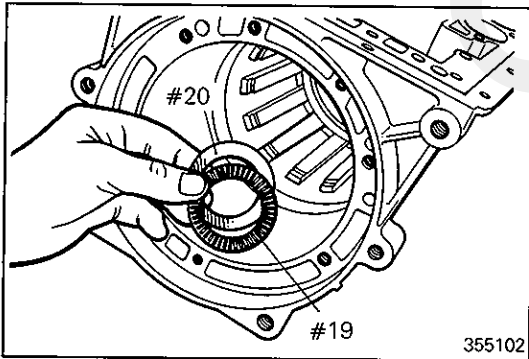

**Transmission with 4th speed gear ratio of 0.688**

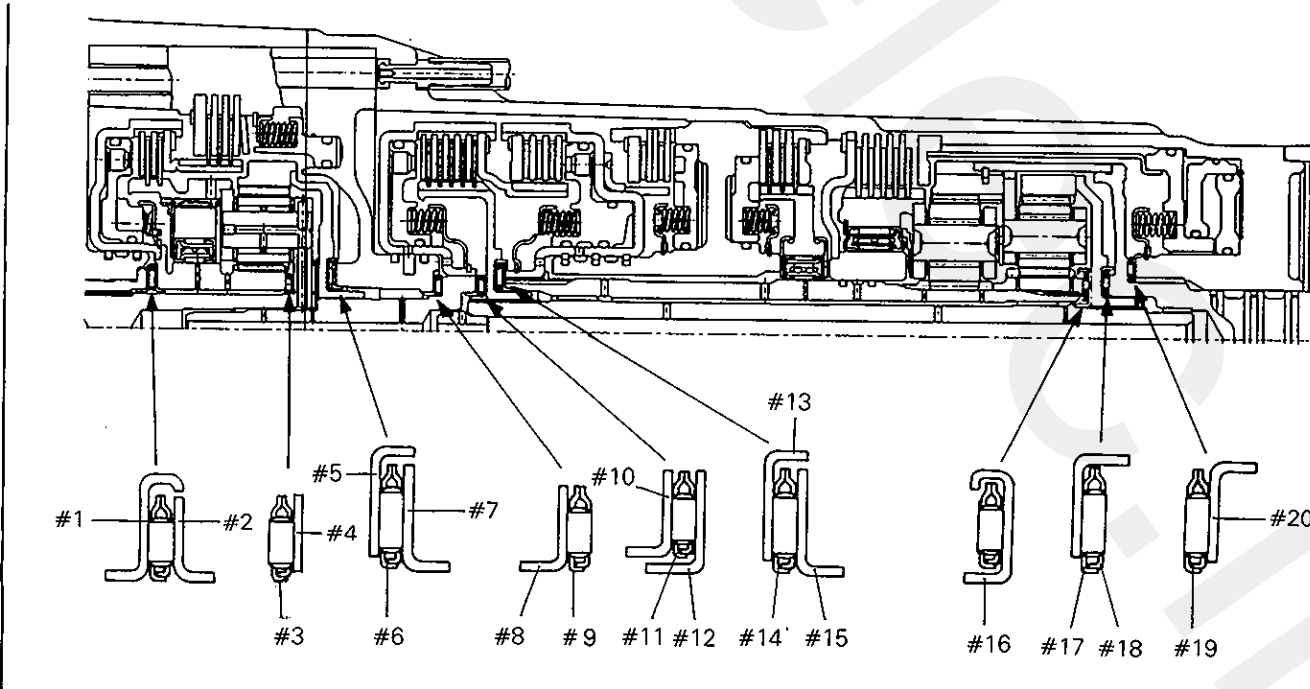

Transmission with 4th gear ratio of 0.730

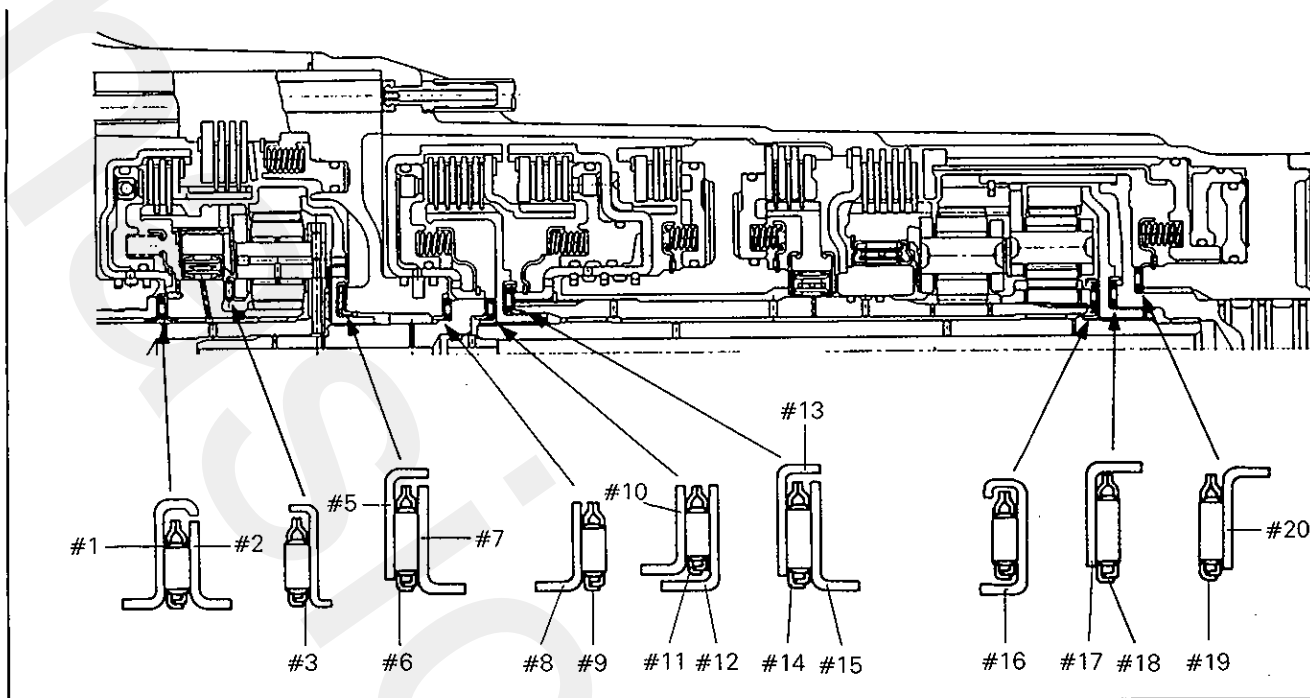

TRA0359

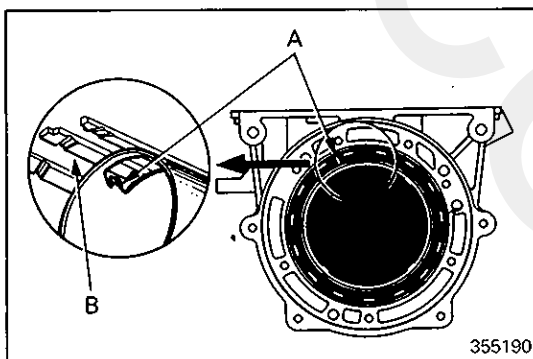

- (3) Install the apply tube in the case. Make sure that the pawl at the end of the tube is inserted to inside of the piston.

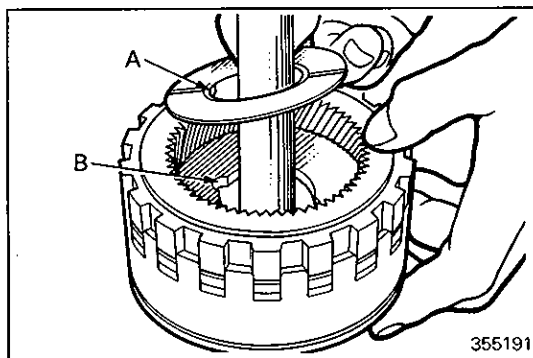

- (4) Install the thrust washer on the planetary carrier, seating its pawl (A) securely in the (B) of the carrier.

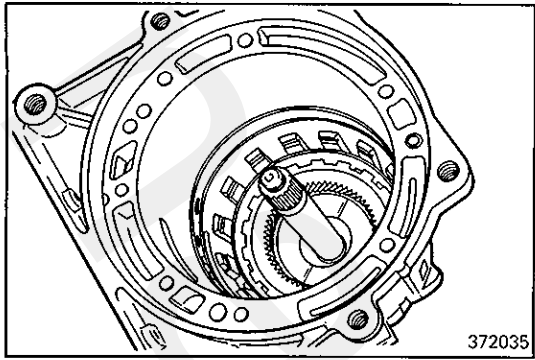

- (5) Install the rear planetary gear and output shaft assembly in the case. Insert slowly and taking care not to hit at the bearing.

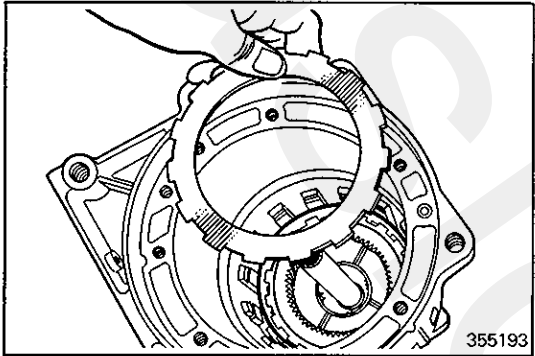

- (6) Install the backing plate in the case. Insert firmly until it comes into contact with the apply tube.

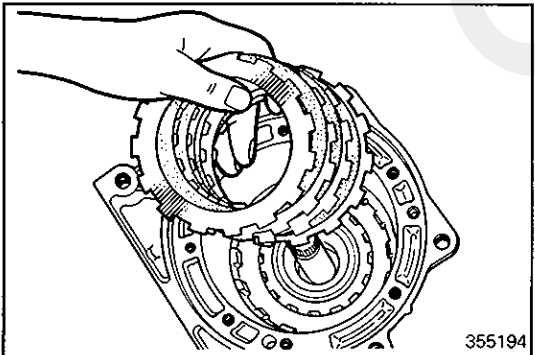

- (7) Apply grease to the thrust washer and attach it to the front planetary gear carrier. Then install the front planetary gear assembly in the ring gear.  
 (8) Install the clutch discs and plates alternately in this order on the backing plate.

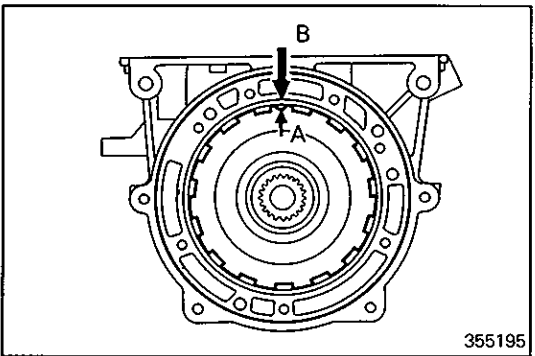

- (9) Place the transmission case on a bench with the oil pan mounting surface up.  
 (10) Insert the sun gear in the one-way clutch inner race and install the assembly in the case, aligning (A) of the one-way clutch inner race with (B) of the case. If the inner race is hard to engage, turn the sun gear while holding the front planetary ring gear. Then, holding the one-way clutch inner race, remove the sun gear. Fit the removed sun gear to the center support.

#### Caution

- Check the snap ring end gap position to make sure that the carrier is seated completely.

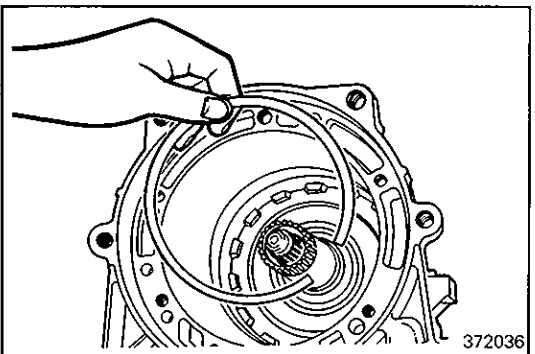

- (11) Install the snap ring.



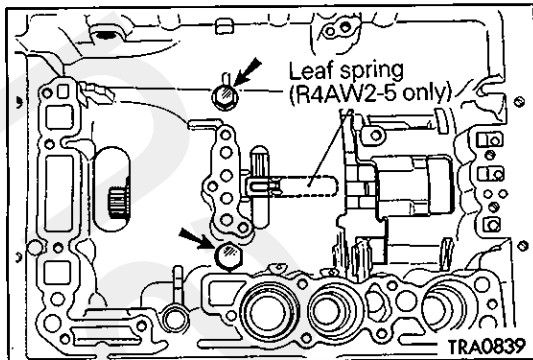

- (12) Install the leaf spring. <R4AW2-5>
- (13) Install the center support assembly in the case, checking correct seating of the one-way clutch on the center support and pushing the center support while pulling the sun gear. The center support will not be installed completely in the case if the one-way clutch is floating.
- (14) Pushing the center support backward, tighten the bolts alternately on side (A) in about 7 Nm (0.7 kgm, 5 ft.lbs.) increments. Finally tighten to specified torque.

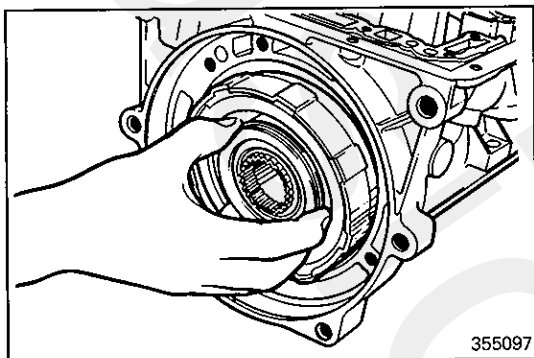

- (15) Install the direct clutch assembly.

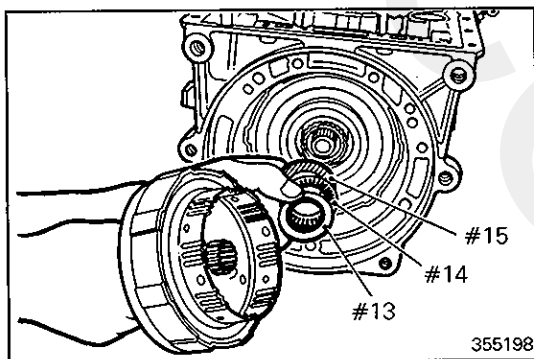

- (16) Attach thrust race #13, bearing #14 and thrust race #15 onto the rear of the forward clutch hub using petrolatum and noting the direction of the thrust bearing race.

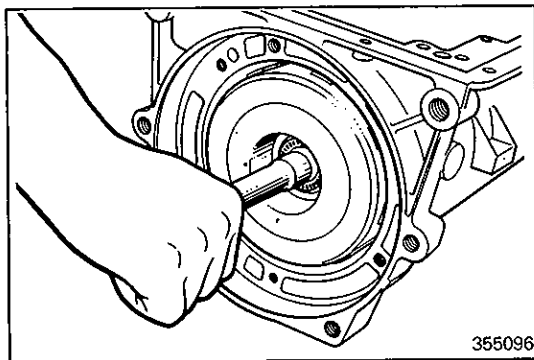

- (17) Install the forward clutch assembly, using care not to drop the thrust bearing attached in the step above.

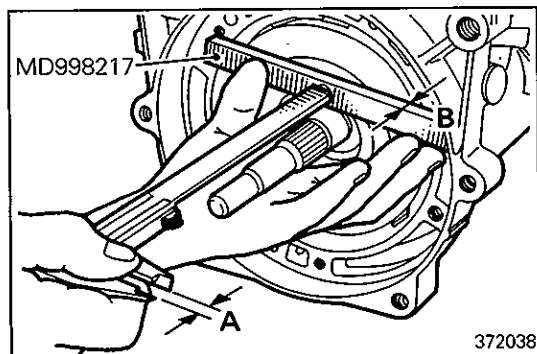

- (18) Check that the forward clutch has been installed completely by using the special tool. Measured value (A) – gauge thickness (B) = forward clutch installation height

**Standard value: Approx. 1.5 mm (0.059 in.)**

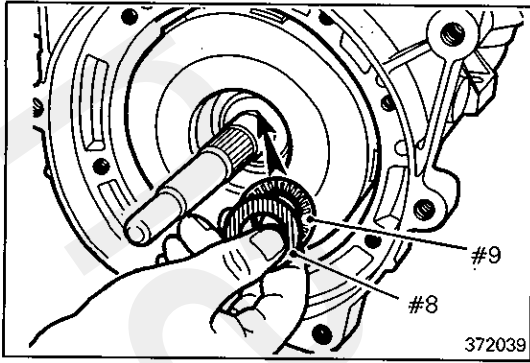

(19) Attach thrust bearing #9 and race #8 to the forward clutch using petrolatum and noting the direction of the thrust bearing race.

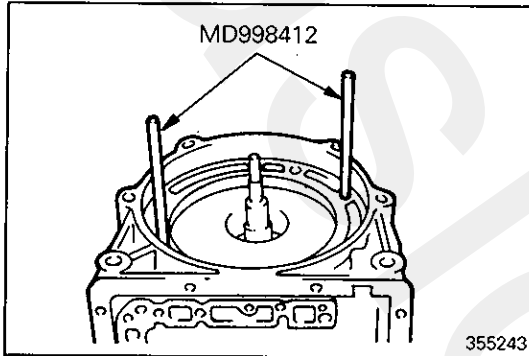

(20) Install special tool in the transmission case.

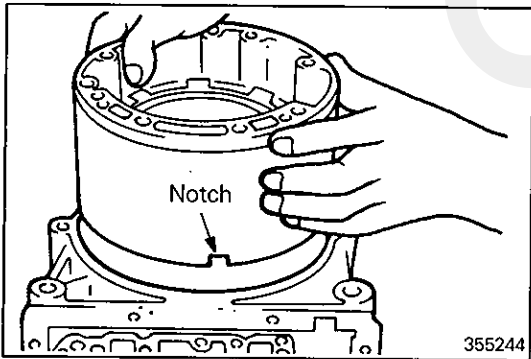

(21) Along the guides, install the O.D. case assembly in the transmission case, positioning the O.D. case notch as illustrated.

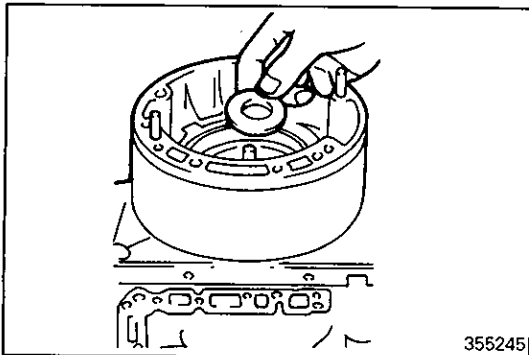

(22) Install the thrust washer on the O.D. planetary gear.

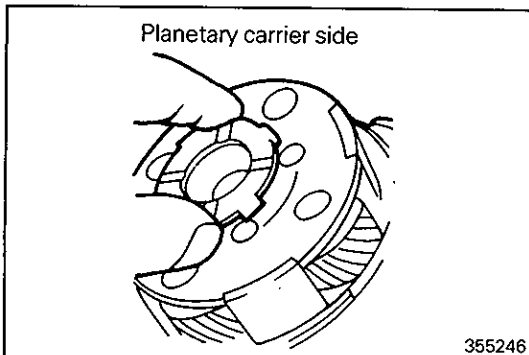

(23) Apply petrolatum to the rear of the O.D. planetary carrier and attach the thrust washer thereon.

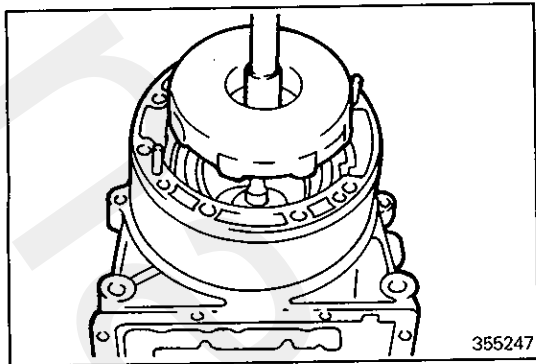

(24) Install the O.D. clutch and planetary gear assembly with the thrust washer in the case slowly.

NOTE  
Align the O.D. case clutch disc lugs.

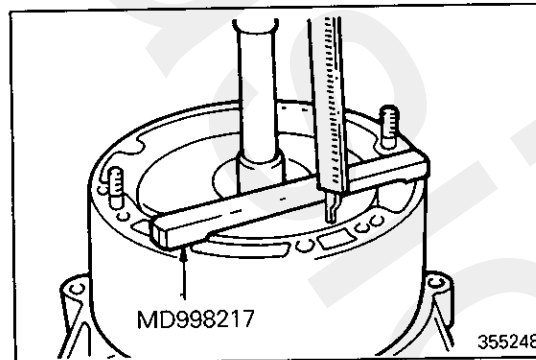

(25) Check that the O.D. clutch and planetary gear set assembly has been installed completely by using the special tool. Measured value – gauge thickness = O.D. clutch assembly installed height

**Standard value: Approx. 2 mm (0.08 in.)**



(26) Install the O-ring at illustrated position and then install the converter housing.

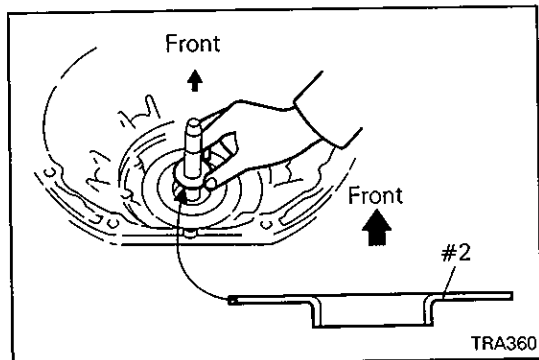

(27) Install thrust bearing race #2 over the O.D. input shaft.

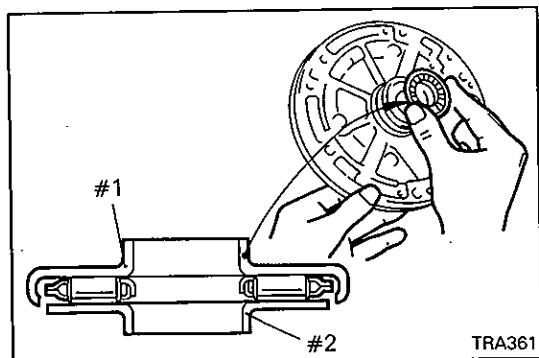

(28) Apply petrolatum to the oil pump and install thrust bearing and race #1.

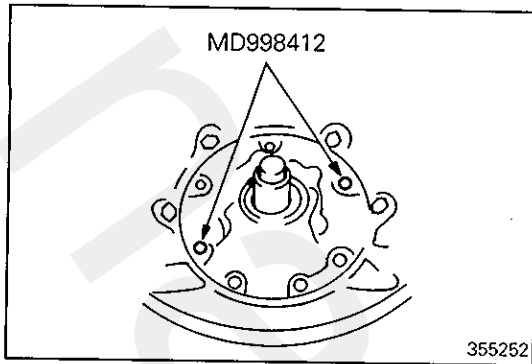

- (29) Install the oil pump slowly by using the special tools.  
 (30) Apply sealer to the set bolts and tighten them uniformly and little by little. Check input shaft end play and check that the shaft turns lightly.

**Specified sealant: 3M ART Part No. 8660 or equivalent**

- (31) Tighten the oil pump assembly attaching bolts to specified torque and check the input shaft end play.

**Standard value: 0.3 – 0.9 mm (0.012 – 0.035 in.)**

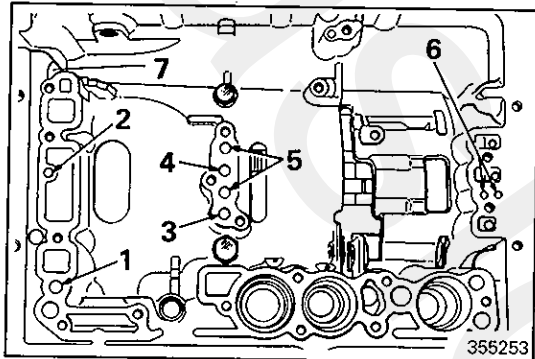

- (32) Supply low pressure air to each circuit and check operation by operating noise.

1. O.D. clutch
2. Forward clutch
3. Brake No. 1
4. Brake No. 2
5. Direct clutch
6. Brake No. 3
7. O.D. brake

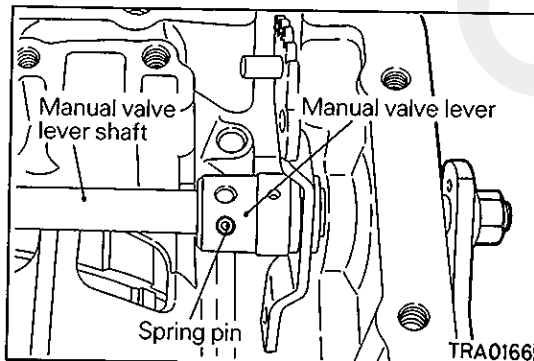

- (33) Install the parking rod assembly on manual valve lever and insert manual valve lever shaft in the case. Then, drive in slotted spring pin.

**Caution**

- Be sure to use a new slotted spring pin.
- Install the slotted spring pin in such a way that its end protrudes approx. 1 mm (0.4 in.) from the lever.

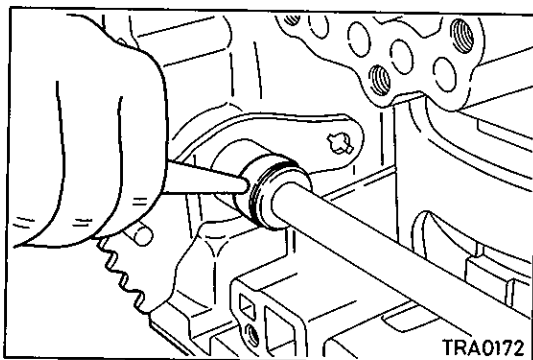

- (34) Align the staking hole in the manual valve lever with the indentation in cover and stake the cover using a punch.

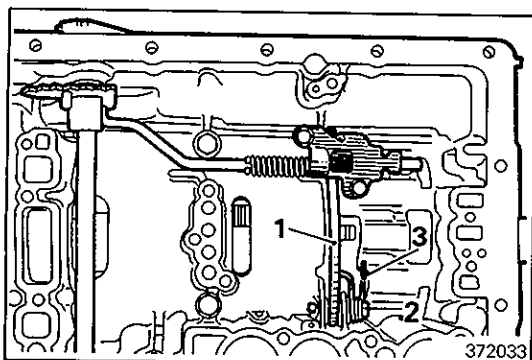

- (35) Place parking pawl 1 in the case and install pivot pin 2 and spring 3.

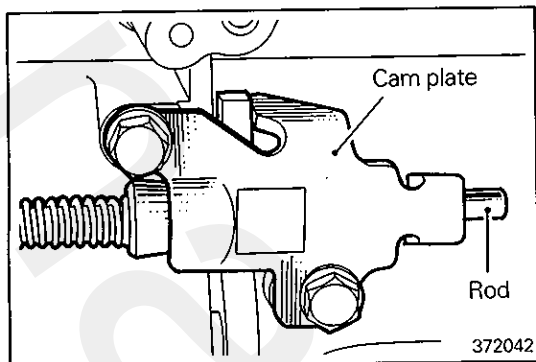

(36) Install the cam plate, making sure that the parking rod assembly protrudes from the cam plate.

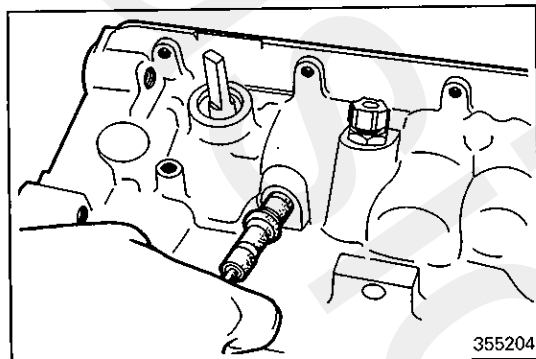

(37) Insert the throttle cable in the case, using care not to damage the O-ring.

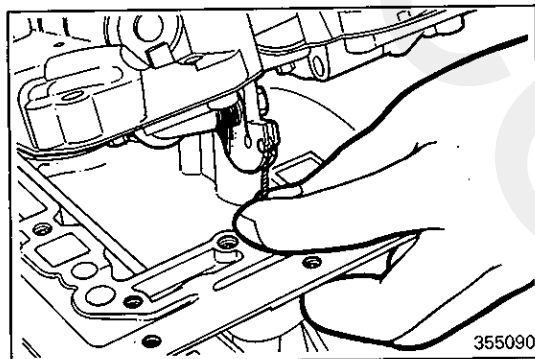

(38) Install accumulator pistons and springs; No. 1 (B2), No. 2 (C2) and No. 3 (C1) from front side.

**NOTE**

For identification of accumulator springs, refer to P.23A-1-6.

(39) Install throttle cable to the throttle cam of the valve body assembly.

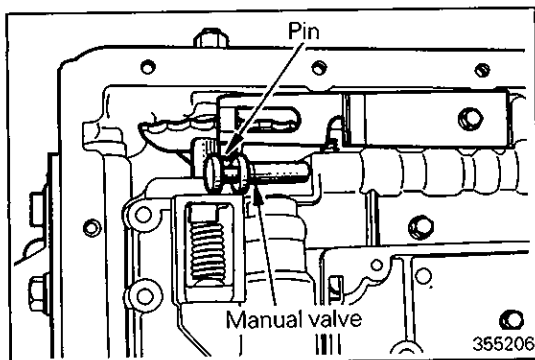

(40) Install two or three valve body attaching bolts temporarily and place the manual valve lever pin in the manual valve groove.

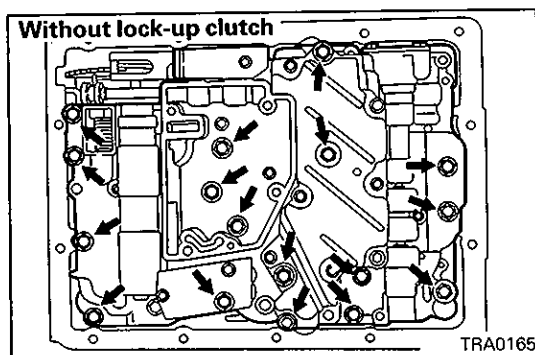

(41) Install 17 valve body attaching bolts and tighten uniformly to specified torque.

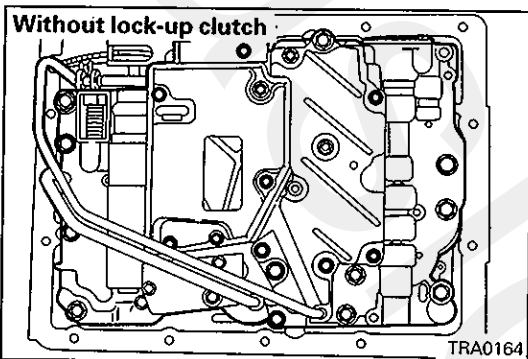
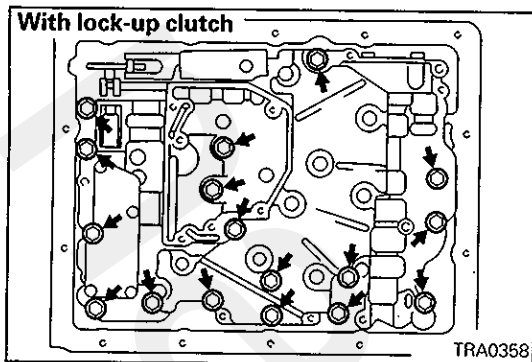

- (42) Install the oil screen and spacer.  
 (43) Shift to "L" and "P" to check that the detent spring roller is completely seated in each portion of the detent lever.  
 (44) Install the oil pipes.

## NOTE:

Oil pipe ① is provided only in the transmissions for vehicles for Europe.

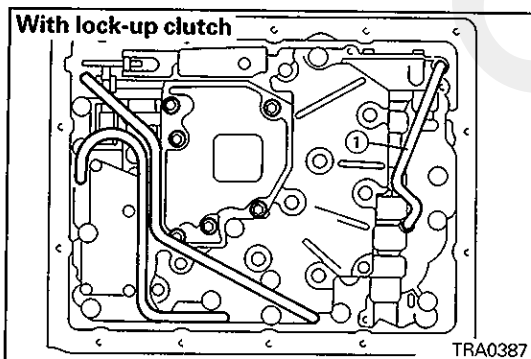

- (45) Attach the magnet to the oil pan (to area directly below the oil screen).  
 (46) Install the oil pan with oil pan gasket attached. First tighten 14 bolts temporarily and then tighten to specified torque uniformly.  
 (47) Install the filter.

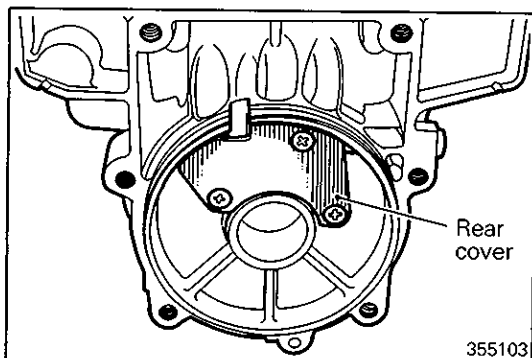
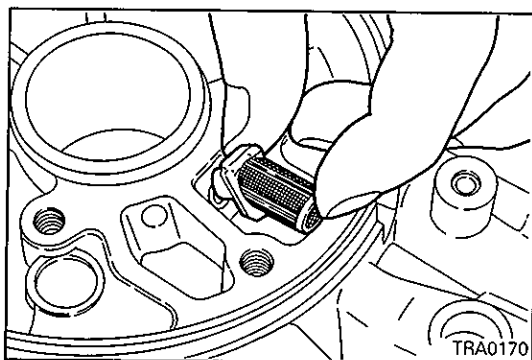

- (48) Install the rear cover on the transmission rear with a rear cover gasket.

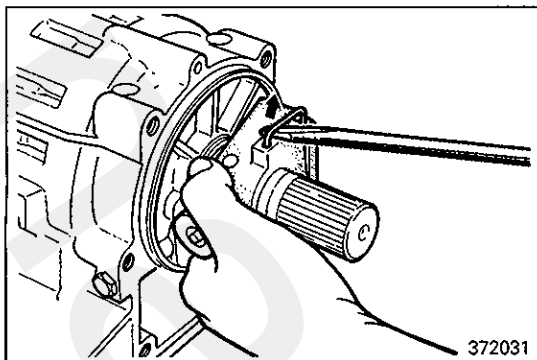

(49) Insert a slot screwdriver between the governor retaining ring and governor body and install the governor to the output shaft.

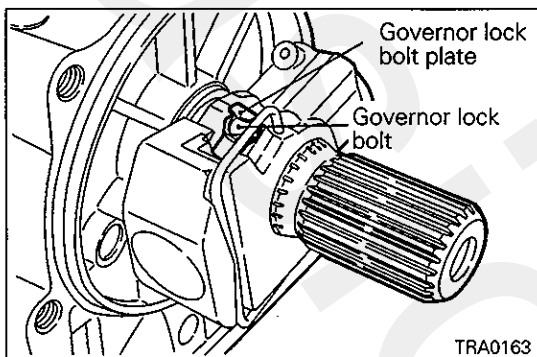

(50) Stake the plate on the governor lock bolt.

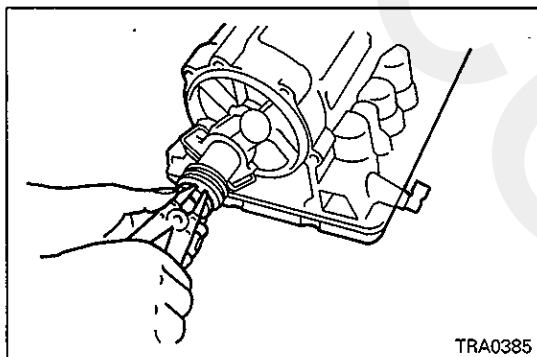

(51) Install the speedometer drive gear and snap ring.  
 (52) Install the extension housing and gasket (2WD).

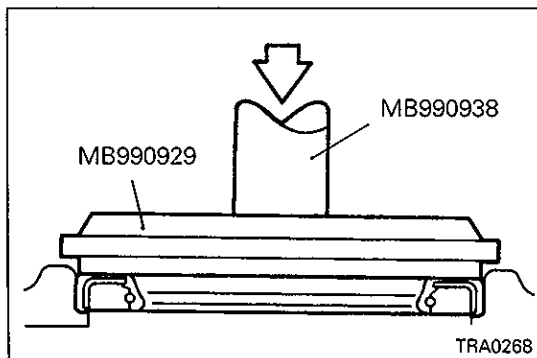

(53) Using a special tool, install an oil seal on the adaptor, and then pack the oil seal lips with grease. (4WD).  
 (54) Install the adapter and gasket (4WD).

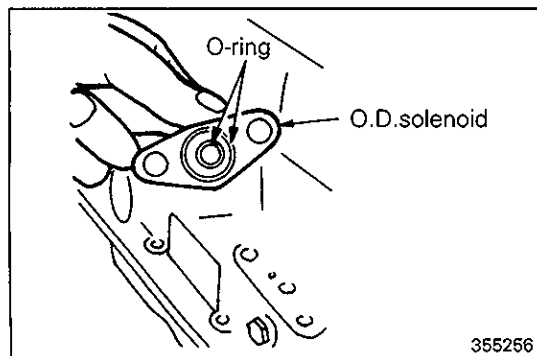

(55) Install the O.D. solenoid with two O-rings.

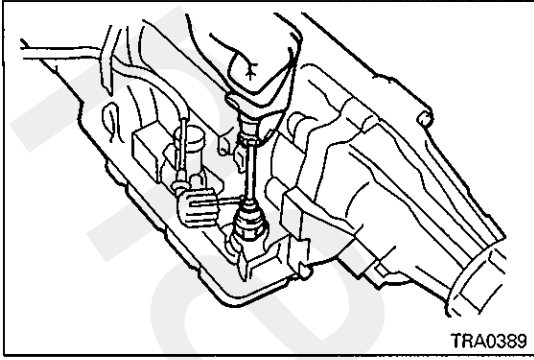

(56) Install the detect switch (EC only).

(57) Apply a sealant to both sides of the adaptor gasket (4WD).

**Specified sealant:**

**Mitsubishi genuine sealant Part No. 997740 or equivalent**

**Caution**

- Squeeze the sealant out evenly to make sure that it is not broken or excessively supplied.

(58) Install the transfer assembly.

(59) Install torque converter to transmission.

**INSPECTION <EC only>**

**INSPECTION OF DETECT SWITCH**

While blowing the low-compressed air into the switch, check the continuity between terminal and switch body.

**Resistance: 0 Ω**

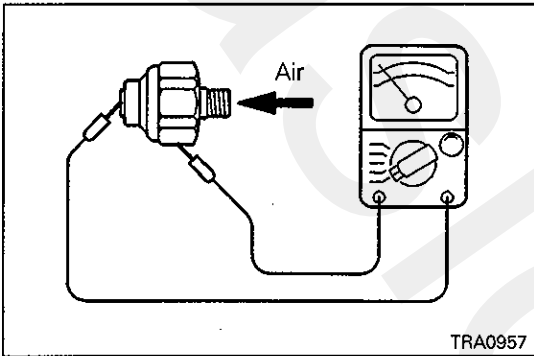



## 4. OIL PUMP

### DISASSEMBLY AND REASSEMBLY

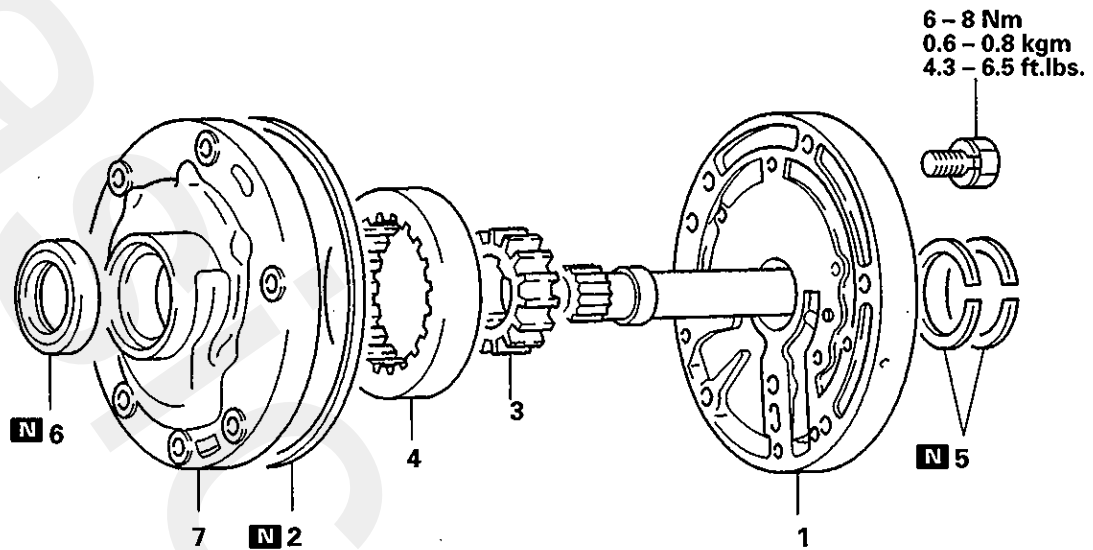

#### Disassembly steps

- 1. Stator support
- 2. O-ring
- Ⓐ Ⓒ 3. Oil pump drive gear
- Ⓐ Ⓒ 4. Oil pump driven gear
- Ⓑ 5. Seal ring
- Ⓐ 6. Oil seal
- 7. Oil pump body

TRA0913

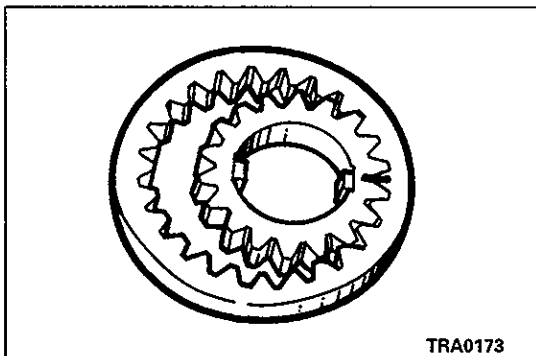

#### SERVICE POINT OF DISASSEMBLY

##### Ⓐ REMOVAL OF OIL PUMP DRIVE GEAR / OIL PUMP DRIVEN GEAR

- (1) Take out the oil pump drive gear and driven gear from the pump body. Put mating marks on the side of removed gears for their reassembly in correct direction. (Use a felt marker or equivalent.)

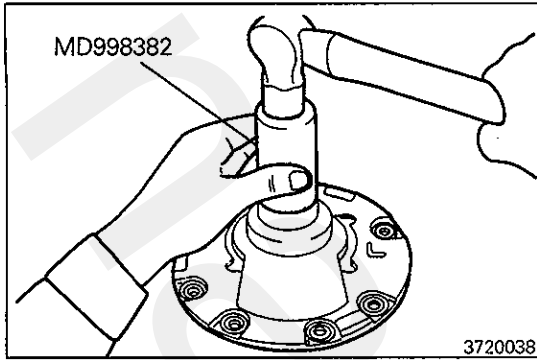
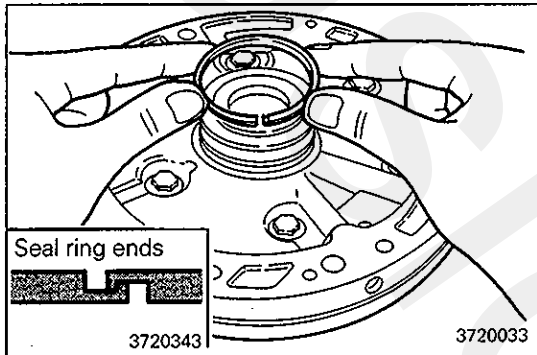
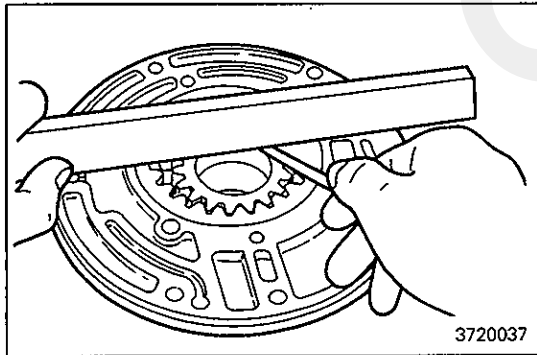
**SERVICE POINT OF REASSEMBLY****A INSTALLATION OF OIL SEAL****B INSTALLATION OF SEAL RINGS****C INSTALLATION OF OIL PUMP DRIVEN GEAR / OIL PUMP DRIVE GEAR**

- (1) Install the driven and drive gears on the oil pump body in correct directions according to the marks put during disassembly.
- (2) Using a steel straightedge and a feeler gauge, measure the side clearance of drive and driven gears.

**Standard value: 0.02 – 0.05 mm (0.0008 – 0.0020 in.)**

**Limit: 0.1 mm (0.004 in.)**

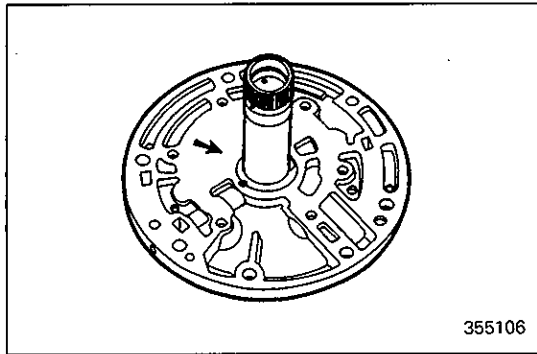
**D INSTALLATION OF STATOR SUPPORT**

- (1) Damage or wear of the stator support surface in contact with the oil pump gear (indicated by arrow).

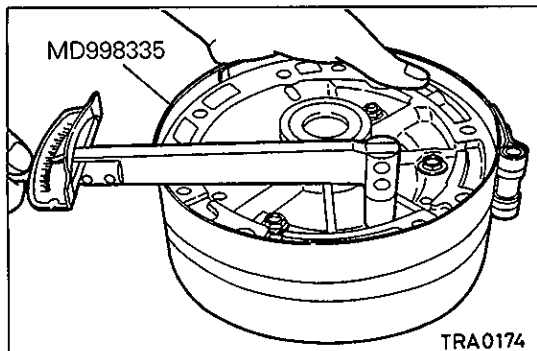

- (2) Assemble the body and stator support and tighten the six bolts finger-tight.
- (3) Tighten outside of the cover and support by using the special tool.
- (4) Tighten the bolts to specified torque.

# 5. OVERDRIVE CLUTCH

## DISASSEMBLY AND REASSEMBLY

### Disassembly steps

- 1. Snap ring No. 2
- 2. OD brake hub
- 3. Snap ring No. 1
- 4. Clutch disc
- 5. Clutch plate
- 6. Cushion plate\*1
- 7. Snap ring
- 8. Return spring and retainer
- 9. OD clutch piston
- 10. OD clutch cylinder
- 11. O-ring
- 12. O-ring

**NOTE:**

\*1 Not provided in transmissions combined with 4G54 engine.

\*2 Except L300 (4G64) and L400 (4G64)

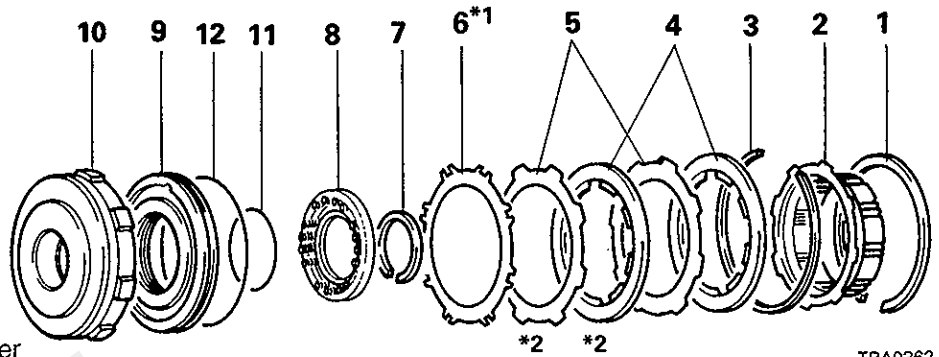

TRA0362

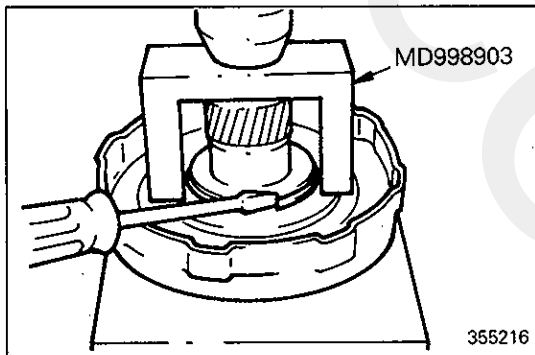

### SERVICE POINT OF DISASSEMBLY

#### Ⓐ REMOVAL OF SNAP RING

- (1) Compress the spring and remove the snap ring by using the special tool.

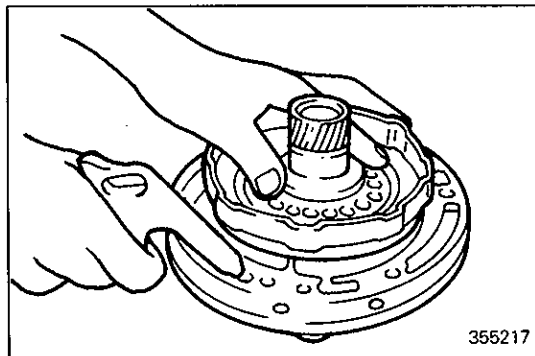

#### Ⓑ REMOVAL OF OVERDRIVE CLUTCH PISTON

- (1) Install the O.D. clutch cylinder on the oil pump and blow air into the oil pump oil hole to remove the piston.

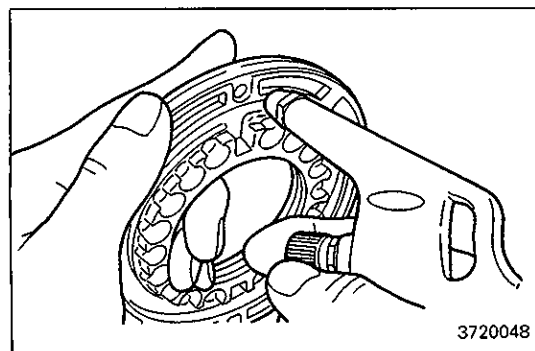

### SERVICE POINT OF REASSEMBLY

#### Ⓐ INSPECTION OF OVERDRIVE CLUTCH PISTON

- (1) Check that the check ball is free by shaking the piston.
- (2) Check that the valve does not leak by applying low-pressure compressed air.

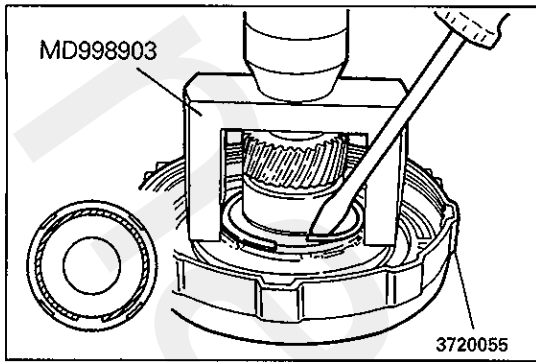
**B INSTALLATION OF SNAP RING**

- (1) Place the special tool on the spring retainer, and compress the springs on shop press.
- (2) Install the snap ring with a screwdriver.  
Be sure the end gap of the snap ring is not aligned with the spring retainer claw.

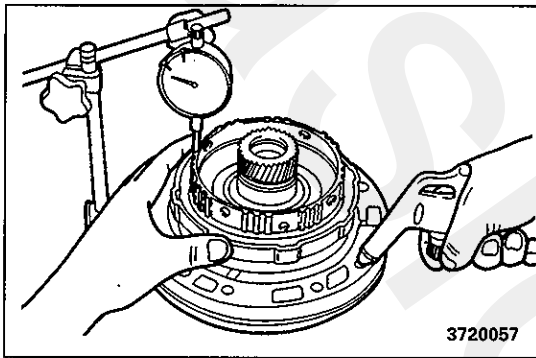
**C INSPECTION OF OVERDRIVE CLUTCH STROKE**

- (1) Place the cushion plate, clutch plates, and clutch discs into the cylinder.
- (2) Install the overdrive brake hub and snap ring No. 2 (the wider one). Do not install snap ring No. 1 (the narrower one).
- (3) Install the overdrive clutch cylinder onto the oil pump body.
- (4) Using a dial indicator, measure the stroke applying and releasing the compressed air (400 – 800 kPa, 4 – 8 kg/cm<sup>2</sup>, 58 – 116 psi) as shown.

**Standard value:**

**1.56 – 2.53 mm (0.061 – 0.100 in.)**

**<2 discs – Without cushion plate>**

**1.92 – 2.64 mm (0.076 – 0.104 in.)**

**<2 discs – With cushion plate>**

**1.77 – 2.58 mm (0.070 – 0.102 in.)**

**<L300 (4G64), L400 (4G64) ... MODEL 1995>**

**1.73 – 2.62 mm (0.068 – 0.103 in.)**

**<L300 (4G64), L400 (4G64) ... MODEL 1996>**

- (5) Remove snap ring No. 2 and overdrive brake hub.

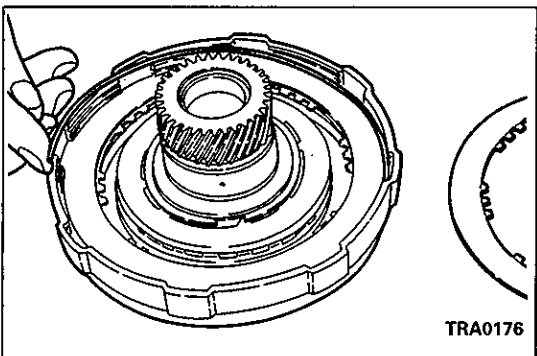
**D INSTALLATION OF SNAP RING NO. 1****NOTE**

To make the job easier, first remove one clutch disc, fit snap ring No. 1 into position, then reinstall the clutch disc back again.

## 6. OVERDRIVE PLANETARY GEAR

### DISASSEMBLY AND REASSEMBLY

#### Disassembly steps

- ▶C◀ 1. Snap ring No. 3
- ▶B◀ 2. One-way clutch retainer
- ▶B◀ 3. One-way clutch outer race
- ▶B◀ 4. One-way clutch assembly
- ▶A◀ 5. Thrust washer
- 6. Thrust bearing #3\*
- 7. Thrust bearing race #4\*
- 8. Thrust bearing #3\*\*
- 9. Pinion shaft plug (4)
- 10. OD planetary gear

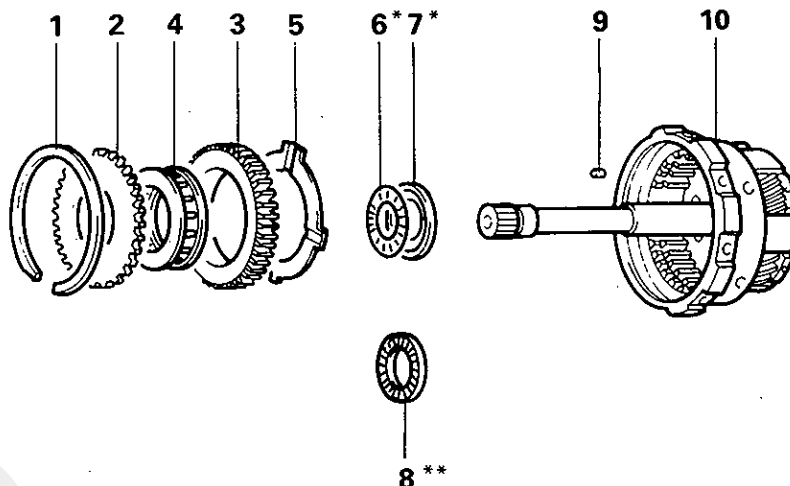

#### NOTE:

\* Transmissions with 4th speed gear ratio of 0.688

\*\* Transmissions with 4th speed gear ratio of 0.730

TRA0390

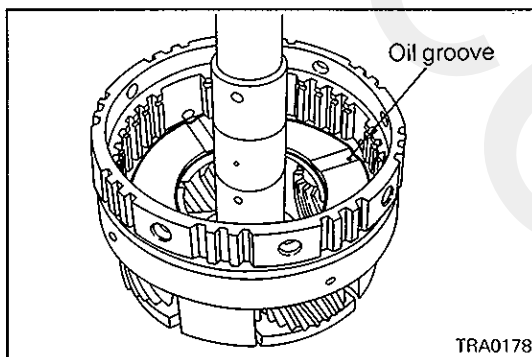

#### SERVICE POINTS OF REASSEMBLY

##### ▶A◀ INSTALLATION OF THRUST WASHER

- (1) Install the thrust washer so that its oil groove faces up.

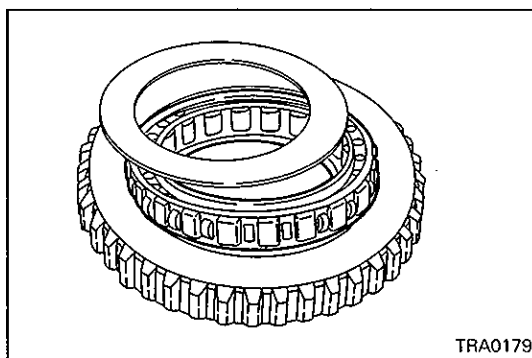

##### ▶B◀ REASSEMBLY OF ONE-WAY CLUTCH

- (1) Reassemble the one-way clutch assembly so that it is oriented as shown.

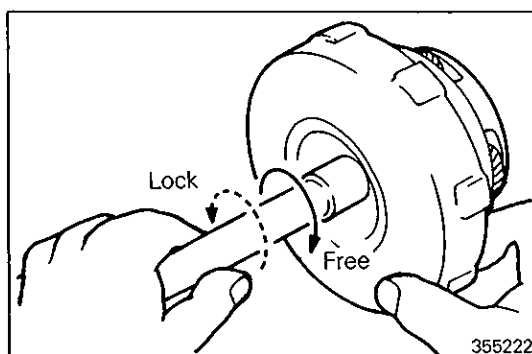

##### ▶C◀ CHECK OPERATION OF ONE-WAY CLUTCH

- (1) With the clutch cylinder held by hand, turn the input shaft clockwise to see that the shaft turns smoothly and turn it counterclockwise to see that the shaft is locked.

University of Cambridge

# 7. OVERDRIVE BRAKE

## DISASSEMBLY AND REASSEMBLY

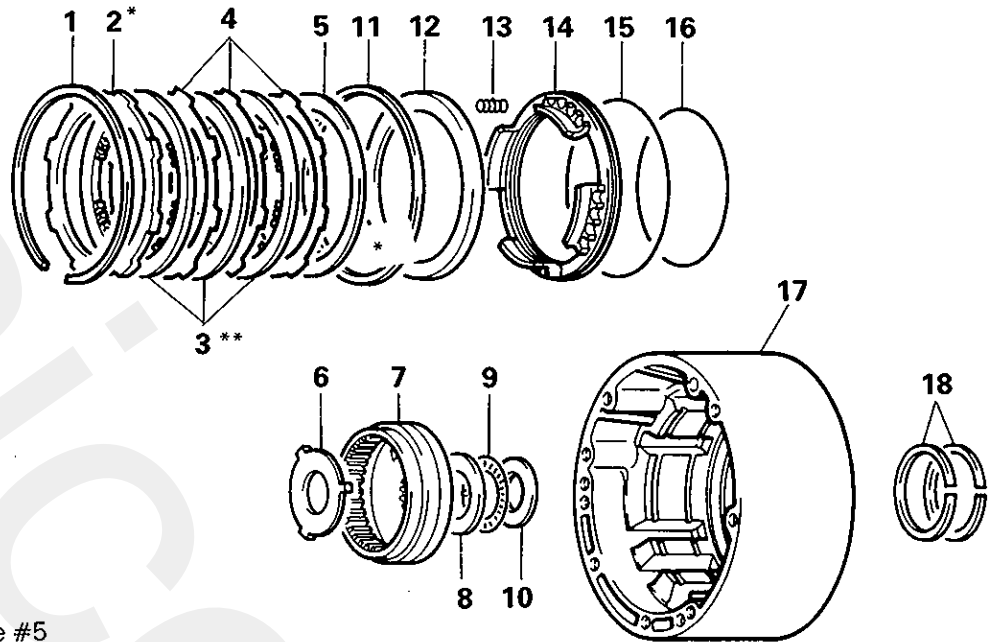

### Disassembly steps

- ▶D▶ 1. Snap ring
- ▶C▶ 2. Flange\*
- ▶C▶ 3. Brake disc\*\*
- ▶C▶ 4. Brake plate
- ▶C▶ 5. Cushion plate
- ▶C▶ 6. Thrust race
- ▶C▶ 7. Planetary ring gear
- ▶B▶ 8. Thrust bearing race #5
- ▶B▶ 9. Thrust bearing #6
- ▶B▶ 10. Thrust bearing race #7
- ▶A▶ 11. Snap ring
- ▶A▶ 12. Spring retainer
- ▶A▶ 13. Return spring
- ◊A◊ 14. Brake piston
- ▶A▶ 15. O-ring
- ▶A▶ 16. O-ring
- ▶A▶ 17. OD case
- ▶A▶ 18. Seal ring

**NOTE:**

- \* Provided only in transmissions combined with 4G54, 4G64, 6G72 or 4D56-Intercooler turbo
- \*\* Two discs for transmissions combined with 4G63 or 4D56

TRA0364

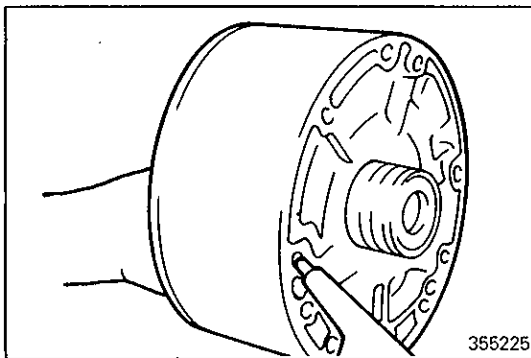

### SERVICE POINT OF DISASSEMBLY

#### ◊A◊ REMOVAL OF BRAKE PISTON

- (1) Blow air into the O.D. case through the oil hole to remove the piston.

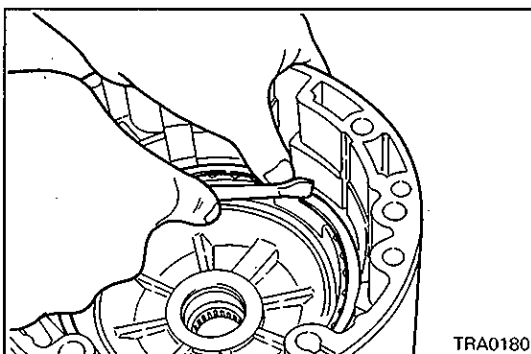

### SERVICE POINTS OF REASSEMBLY

#### ▶A▶ INSTALLATION OF RETURN SPRING, SPRING RETAINER AND SNAP RING

- (1) Fit the spring into the piston carefully not allowing the spring to tilt.
- (2) Holding the retainer with your fingers, fit the snap ring into the groove in the O.D. case.

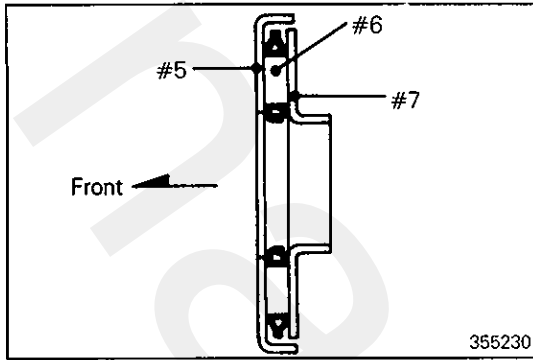

**B** INSTALLATION OF THRUST BEARING AND THRUST BEARING RACE

- (1) Make sure that thrust bearing races #5 and #7 and thrust bearing #6 face as shown when they are installed.

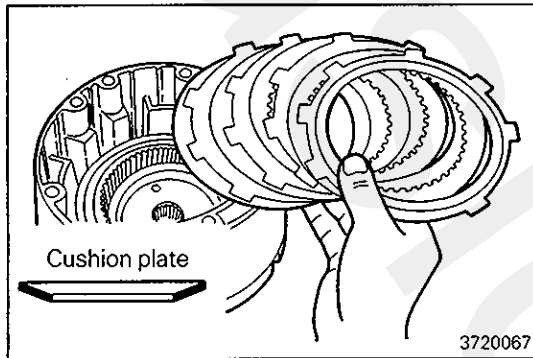

**C** INSTALLATION OF CUSHION PLATE, BRAKE PLATE, BRAKE DISC AND FLANGE

- (1) Make sure that the cushion plate and flange face the correct direction when installed.

Cushion plate ..... rounded end down  
 Flange ..... flat end down

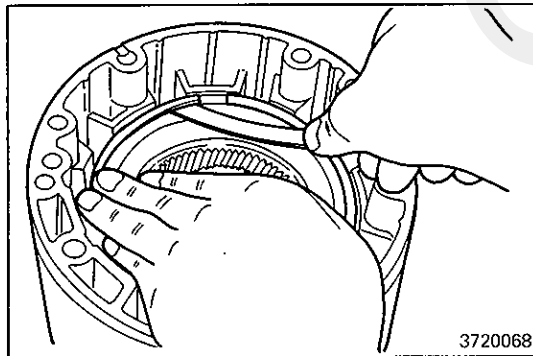

**D** INSPECTION OF OVERDRIVE BRAKE CLEARANCE

- (1) Measure the distance between snap ring and flange with feeler gauge to check the brake clearance.

**Standard clearance:**  
 0.56 – 1.92 mm (0.022 – 0.076 in.) ..... Two discs  
 0.65 – 2.21 mm (0.026 – 0.087 in.) ..... Three discs



## 8. FORWARD CLUTCH

### DISASSEMBLY AND REASSEMBLY

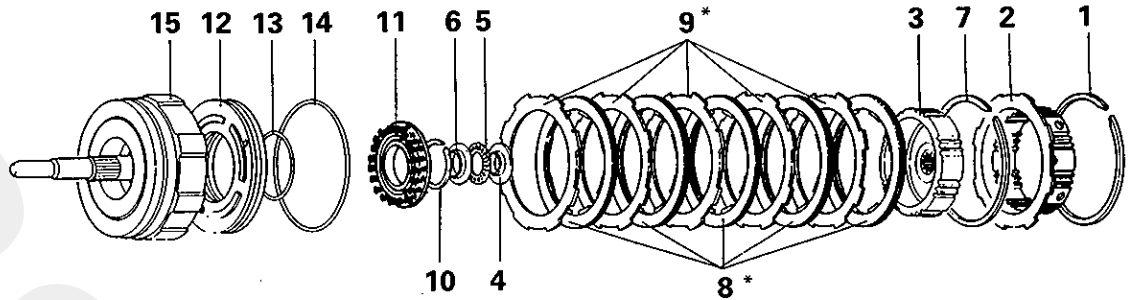

#### Disassembly steps

- E** 1. Snap ring
- 2. Direct clutch hub
- 3. Forward clutch hub
- 4. Thrust bearing race #12
- 5. Thrust bearing #11
- 6. Thrust bearing race #10
- D** 7. Snap ring
- C** 8. Clutch disc\*
- C** 9. Clutch plate\*
- B** 10. Snap ring
- B** 11. Clutch return spring and retainer
- A** 12. Forward clutch piston
- 13. O-ring
- 14. O-ring
- 15. Forward clutch cylinder assembly

NOTE:  
\* 4 plates for transmissions combined with 4G63 or 4D56

TRA0365

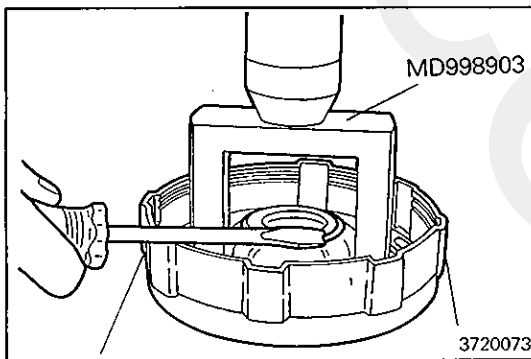

#### SERVICE POINTS OF DISASSEMBLY

##### **A** REMOVAL OF SNAP RING

- (1) Place the front clutch cylinder on a press bench and compress the clutch return spring by using the special tool. Remove the snap ring.

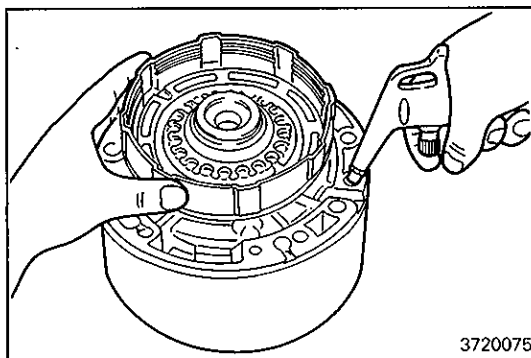

##### **B** REMOVAL OF FORWARD CLUTCH PISTON

- (1) Assemble the forward clutch cylinder and piston on the overdrive case and force out the piston by compressed air.

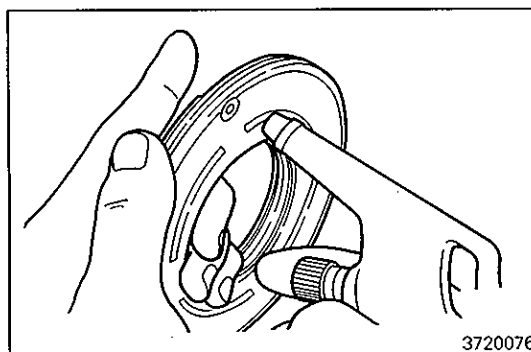

#### SERVICE POINTS OF REASSEMBLY

##### **A** INSPECTION OF FORWARD CLUTCH PISTON

- (1) Check that check ball is free by shaking the forward clutch piston.
- (2) Check that the valve does not leak by applying low-pressure compressed air.

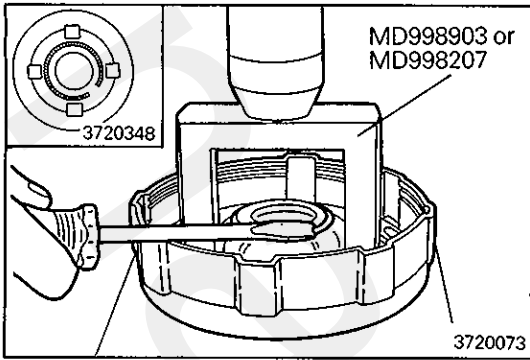
**B INSTALLATION OF SNAP RING**

- (1) Set the special tool on the spring retainer, and compress the springs on a shop press.
- (2) Install the snap ring using a screwdriver.  
Be sure the end gap of snap ring is not aligned with the spring retainer claw.

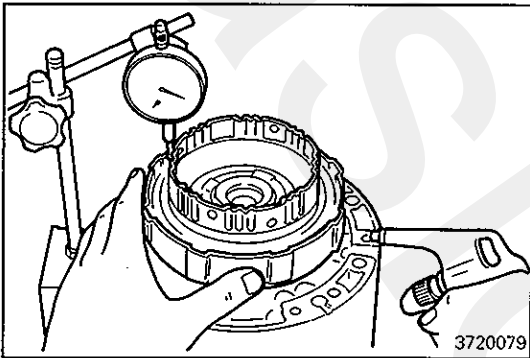
**C INSPECTION OF FORWARD CLUTCH PISTON STROKE**

- (1) Install the clutch plates and discs alternately. Do not install the snap ring (thinner) yet.
- (2) Install the direct clutch hub and snap ring (thicker).
- (3) Install the forward clutch cylinder assembly onto the overdrive case.

Using a dial indicator, measure the stroke applying and releasing the compressed air (400 – 800 kPa, 4 – 8 kg/cm<sup>2</sup>, 58 – 116 psi).

**Standard stroke:**

1.32 – 2.66 mm (0.05 – 0.1 in.)	.....	<b>Four discs</b>
1.43 – 2.93 mm (0.06 – 0.1 in.)	.....	<b>Five discs</b>

- (4) After the check, remove the snap ring and direct clutch hub.

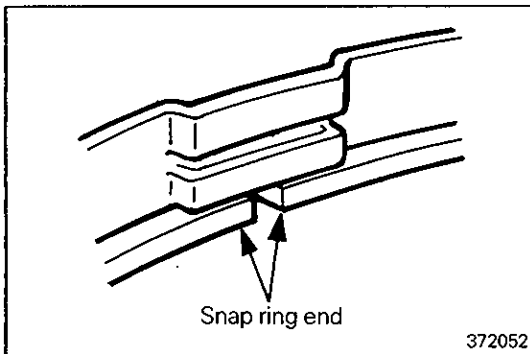
**D INSTALLATION OF SNAP RING**

- (1) With one clutch disc removed, fit the snap ring into position.
- (2) The snap ring should be located with its ends as illustrated.
- (3) Reinstall the clutch disc which has been removed in step (1).

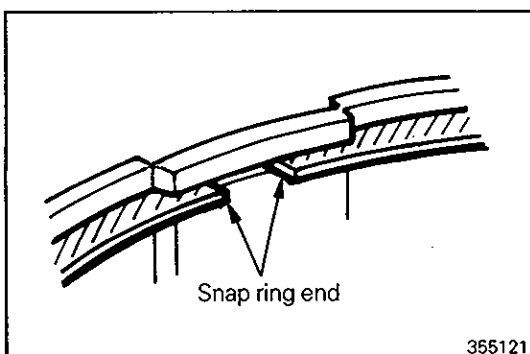
**E INSTALLATION OF SNAP RING**

- (1) Install the snap ring so that its ends are located as shown on the left.

# 9. DIRECT CLUTCH

## DISASSEMBLY AND REASSEMBLY

### Disassembly steps

- 1. Snap ring
- 2. Flange
- 3. Clutch disc
- 4. Clutch plate
- 5. Snap ring
- 6. Piston return spring and retainer
- 7. Direct clutch piston
- 8. Direct clutch outer piston\*\*
- 9. Direct clutch inner piston\*\*
- 10. O-ring
- 11. O-ring
- 12. O-ring
- 13. Direct clutch cylinder

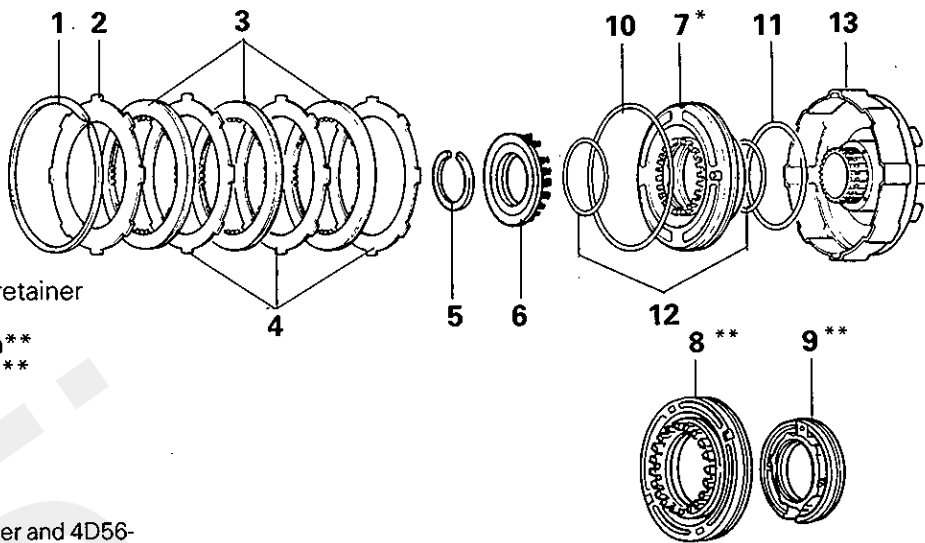

**NOTE:**

\* 4G54, 4G64, 6G72, 4D56-turbocharger and 4D56-turbocharger and intercooler

\*\* 4G63 and 4D56

TRA0391

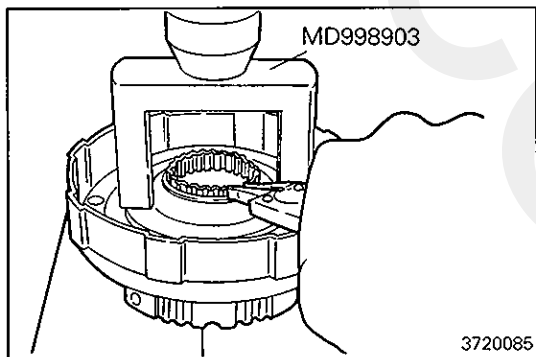

### SERVICE POINTS OF DISASSEMBLY

#### (A) REMOVAL OF SNAP RING

- (1) Place the rear clutch on a press bench, compress the return spring by using the special tool to remove the snap ring.

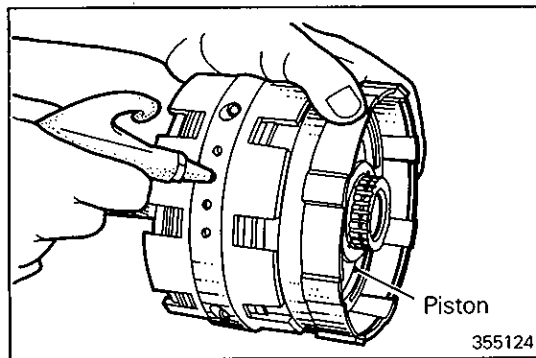

#### (B) REMOVAL OF DIRECT CLUTCH PISTON

- (1) Install the clutch cylinder in the center support and blow air through the oil hole of the center support to remove the piston from the cylinder.

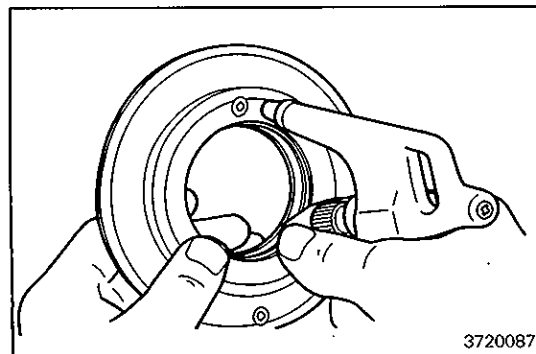

### SERVICE POINTS OF REASSEMBLY

#### (A) INSPECTION OF DIRECT CLUTCH PISTON

- (1) Check that the check ball is free by shaking each piston.
- (2) Check that the valve does not leak by applying low-pressure compressed air.

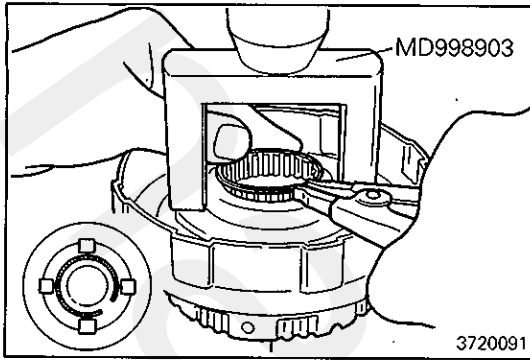
**B INSTALLATION OF SNAP RING**

- (1) Compress the return spring, fit the snap ring by using the special tool.
- (2) Be sure the end gap of the snap ring is not aligned with the spring retainer claw.

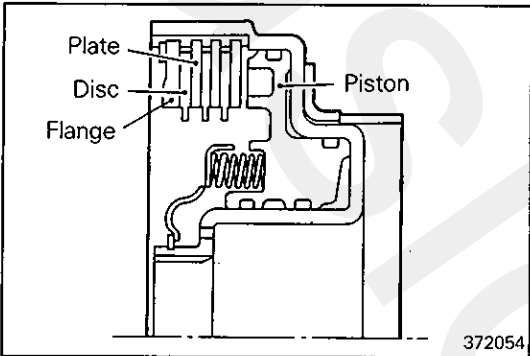
**C INSTALLATION OF CLUTCH PLATE, CLUTCH DISC, FLANGE AND SNAP RING**

- (1) Make sure that the flat end of the flange faces down.

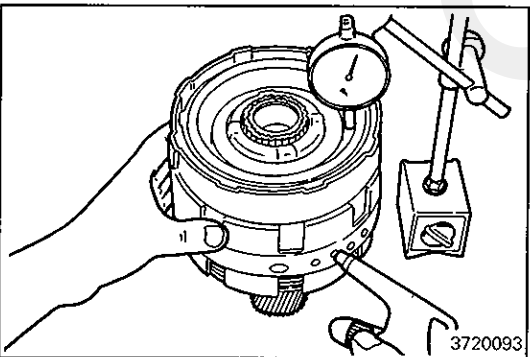
**D INSPECTION OF FORWARD CLUTCH PISTON STROKE**

- (1) Install the direct clutch onto the center support. Using a dial indicator, measure the stroke applying and releasing the compressed air (400 – 800 kPa, 4 – 8 kg/cm<sup>2</sup>, 58 – 116 psi) as shown.

**Standard piston stroke:**

0.91 – 1.99 mm (0.04 – 0.08 in.)	.....	Single piston
1.06 – 2.14 mm (0.04 – 0.08 in.)	.....	Double piston

# 10. CENTER SUPPORT DISASSEMBLY AND REASSEMBLY

## Disassembly steps

- 1. Snap ring
- G** 2. One-way clutch assembly
- 3. Planetary sun gear
- 4. Seal ring
- E** 5. Snap ring
- E** 6. Flange
- E** 7. Brake disc
- E** 8. Brake plate
- A** 9. Snap ring
- B** 10. Spring and retainer
- 11. No. 1 brake piston
- 12. O-ring
- 13. O-ring
- 14. Seal ring
- B** 15. Snap ring
- C** 16. Flange
- B** 17. Brake disc
- B** 18. Brake plate
- B** 19. Snap ring
- C** 20. Spring and retainer
- D** 21. No. 2 brake piston
- 22. O-ring
- 23. O-ring
- 24. Center support

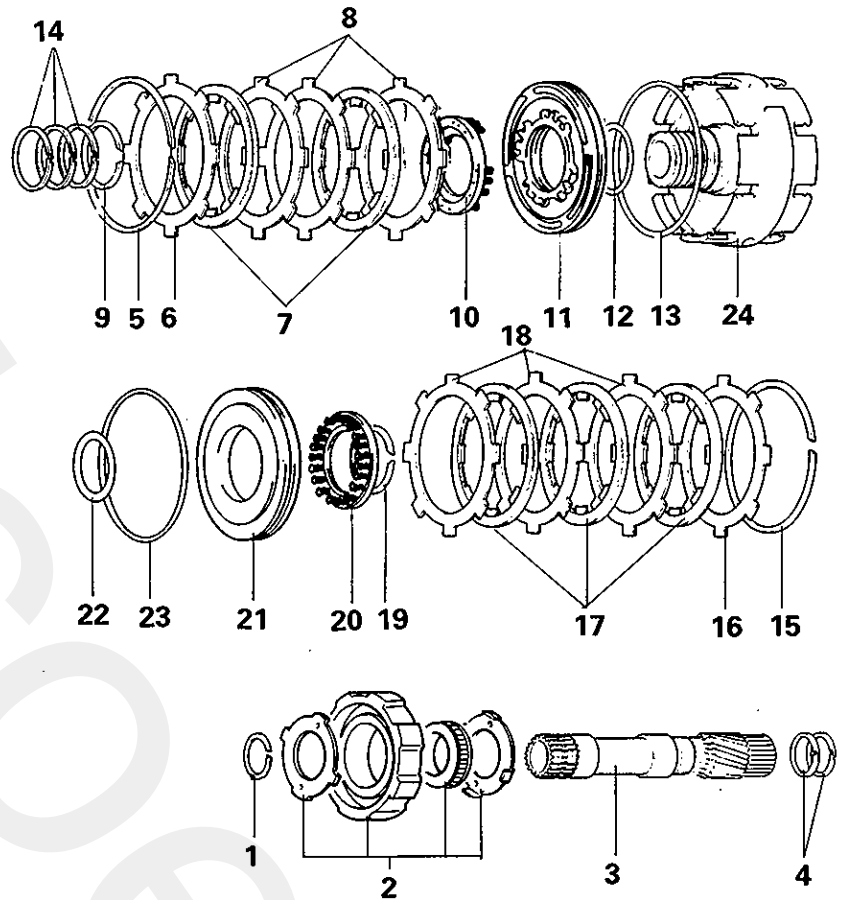

TRA0367

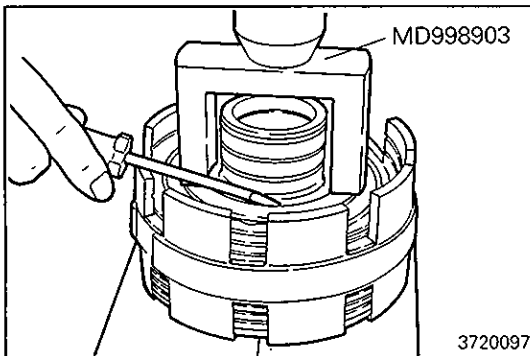

## SERVICE POINTS OF DISASSEMBLY

### **A** REMOVAL OF SNAP RING

- (1) Set the special tool on the spring retainer and compress the springs with a shop press. Using a screwdriver, remove the snap ring.

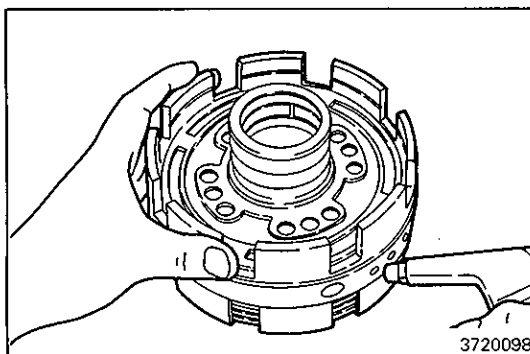

### **B** REMOVAL OF NO. 1 BRAKE PISTON

- (1) Blow compressed air through the center support oil hole to remove the No. 1 brake piston.

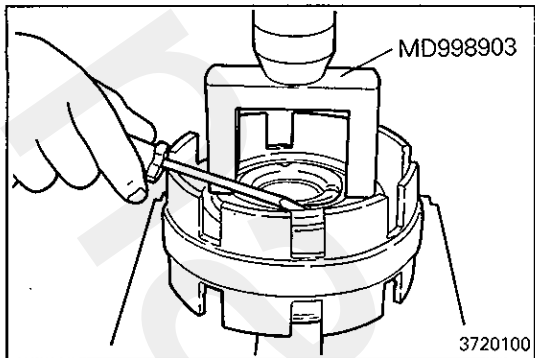
**© REMOVAL OF SNAP RING**

- (1) Set the special tool on the spring retainer and compress the springs with a shop press.  
Using a screwdriver, remove the snap ring.

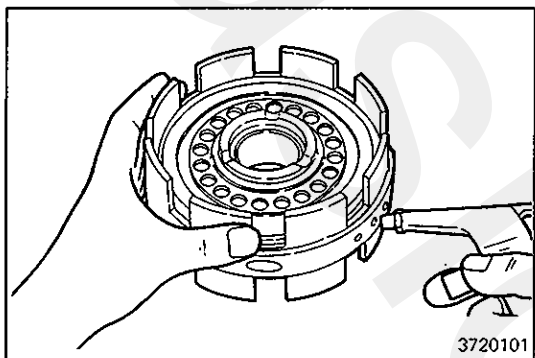
**© REMOVAL OF NO. 2 BRAKE PISTON**

- (1) Blow compressed air through the center support oil hole to remove the No. 2 brake piston.

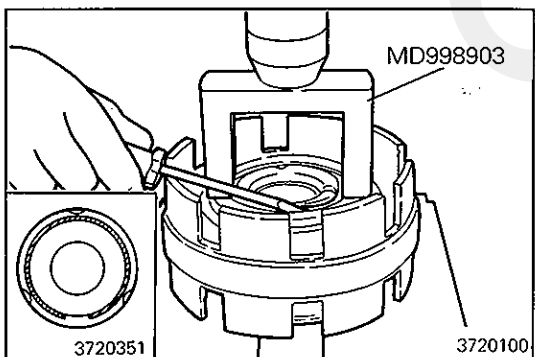
**SERVICE POINT OF REASSEMBLY****▲ INSTALLATION OF SNAP RING**

- (1) Set the special tool on the spring retainer, and compress the springs on a shop press.  
Install the snap ring with a screwdriver.  
Be sure the end gap of the snap ring is not aligned with the spring retainer claw.

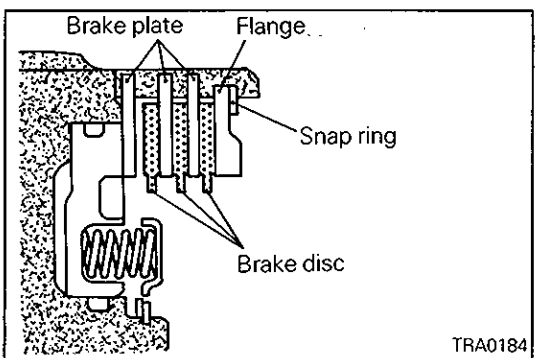
**▲ INSTALLATION OF BRAKE PLATE, BRAKE DISC, FLANGE AND SNAP RING**

- (1) Make sure that the flat end of the flange faces down.

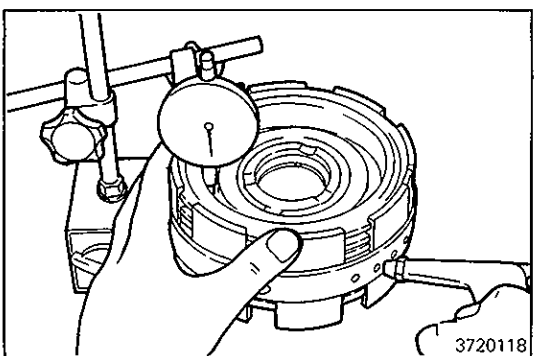
**© INSPECTION OF NO. 2 BRAKE PISTON STROKE**

- (1) Using a dial indicator, measure the stroke applying and releasing the compressed air (400 – 800 kPa, 4 – 8 kg/cm<sup>2</sup>, 58 – 116 psi) as shown.

**Standard piston stroke:**

**1.01 – 2.25 mm (0.040 – 0.089 in.)**

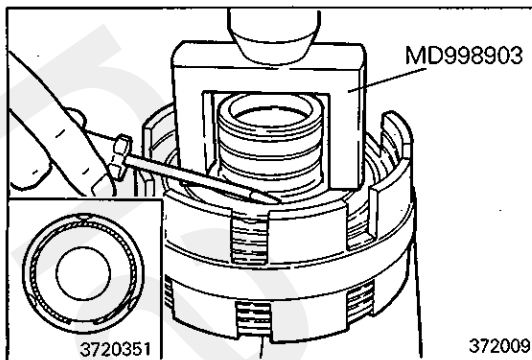

**D INSTALLATION OF SNAP RING**

- (1) Set the special tool on the spring retainer, and compress the springs on a shop press. Install the snap ring with a screwdriver. Be sure the end gap of the snap ring is not aligned with the spring retainer claw.

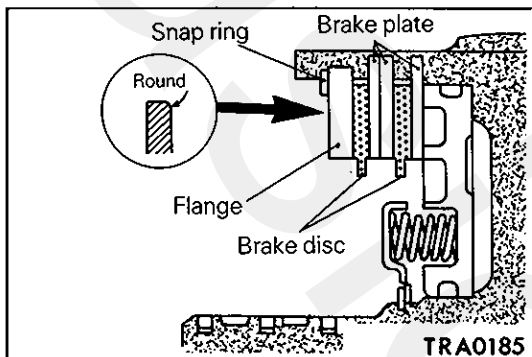

**E INSTALLATION OF BRAKE PLATE, BRAKE DISC, FLANGE AND SNAP RING**

- (1) Make sure the brake plates are installed in the correct order and the round edge of the flange faces down.

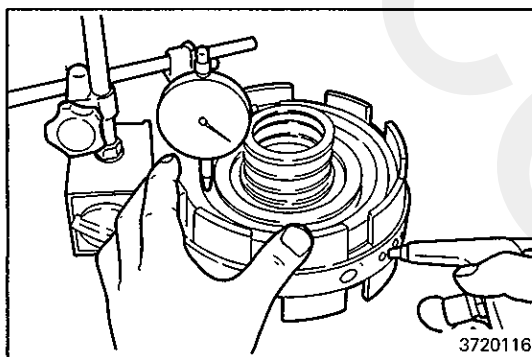

**F INSPECTION OF NO. 1 BRAKE PISTON STROKE**

- (1) Using a dial indicator, measure the stroke applying and releasing the compressed air (400 – 800 kPa, 4 – 8 kg/cm<sup>2</sup>, 58 – 116 psi) as shown.

**Standard piston stroke:**

**0.80 – 1.73 mm (0.031 – 0.068 in.)**

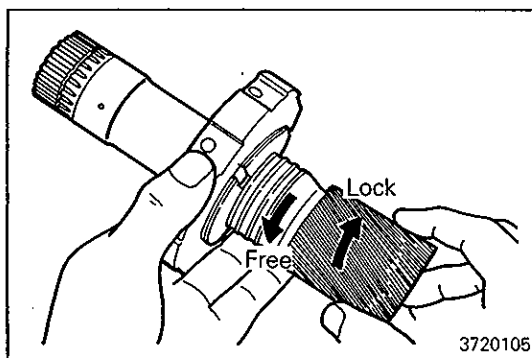

**G INSPECTION OF ONE-WAY CLUTCH ASSEMBLY**

- (1) Hold the No. 2 brake hub and turn the planetary sun gear. The sun gear should turn freely counterclockwise and should lock clockwise. If the one-way clutch does not operate properly, replace it.

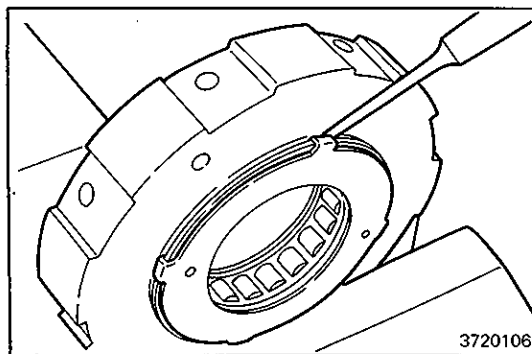

- (2) If necessary, replace the one-way clutch:
  - (a) Bend the tabs back with a tapered punch.
  - (b) Pry off the retainer with a screwdriver. Leave the other retainer on the hub.
  - (c) Remove the one-way clutch.

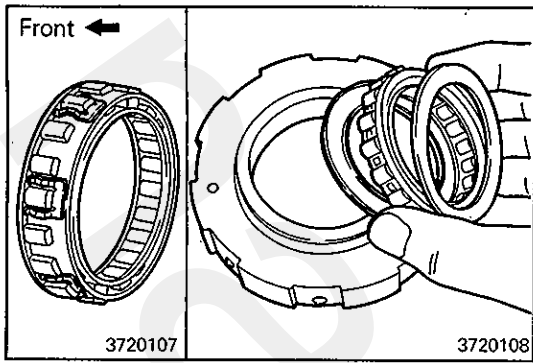

(d) Install the one-way clutch into the brake hub facing the spring cage toward the front.

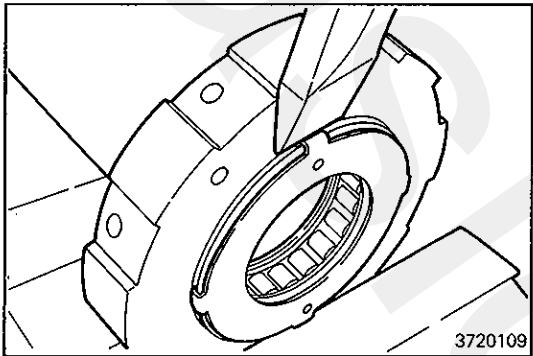

(e) Hold the brake hub in vise with soft jaws, and bend the tabs with a chisel.

(f) Check to make sure that the retainer is centered.



# 11. FRONT PLANETARY GEAR DISASSEMBLY AND REASSEMBLY

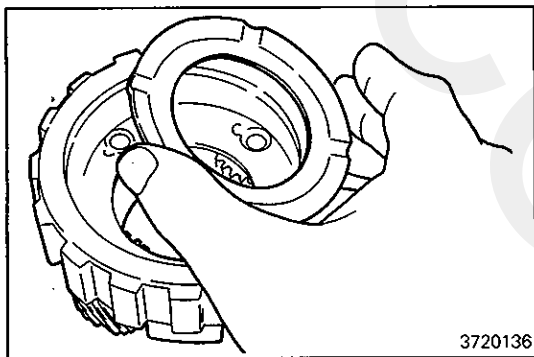
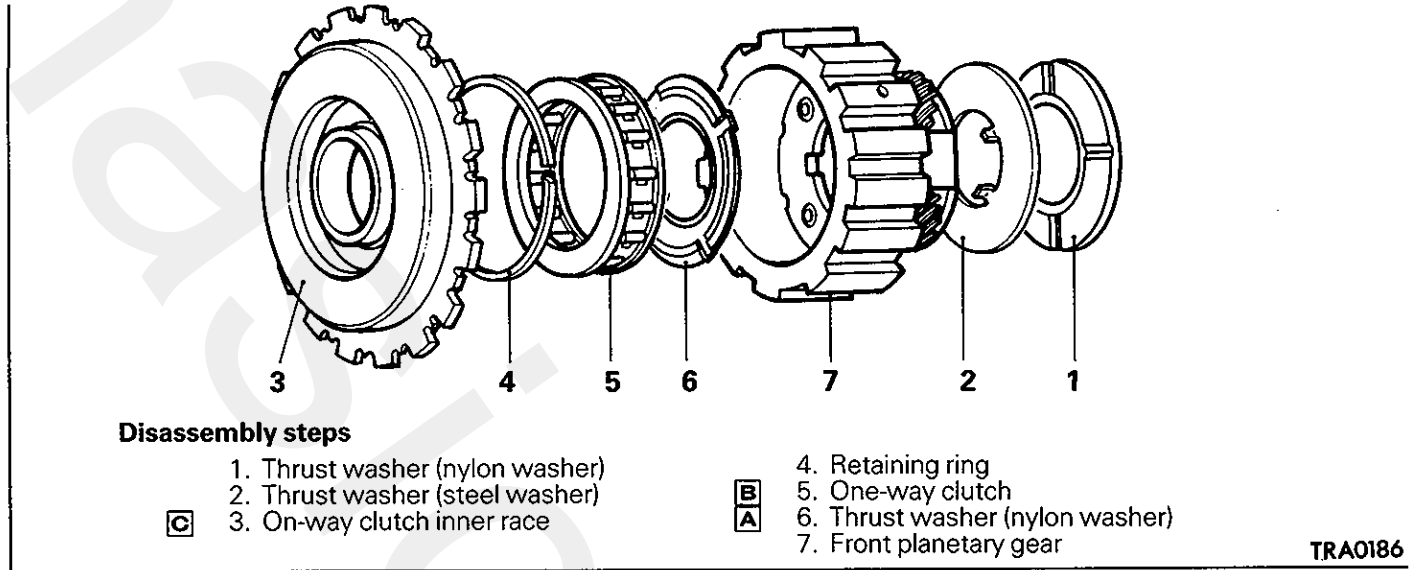

## SERVICE POINT OF REASSEMBLY

### **A** INSTALLATION OF THRUST WASHER

(1) Install the thrust washer so that its oil grooves face up.

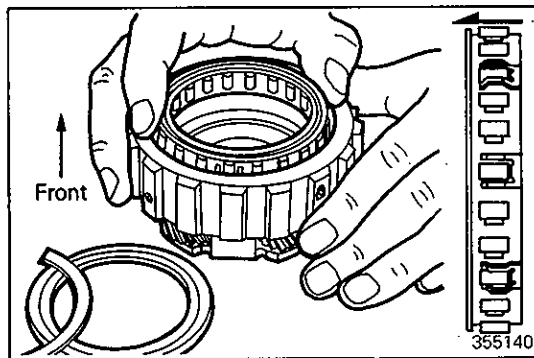

### **B** INSTALLATION OF ONE-WAY CLUTCH

(1) Install the one-way clutch into the front planetary gear, ensuring the one-way clutch facing the correct direction.

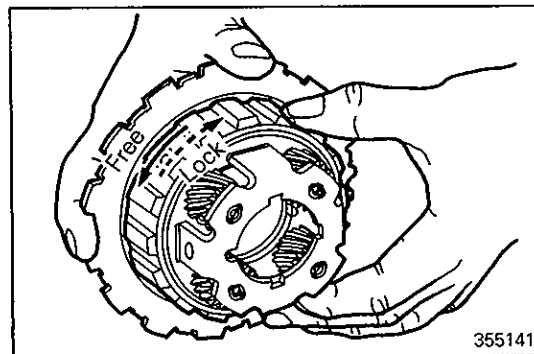

### **C** INSPECTION OF ONE-WAY CLUTCH

(1) Fix the inner race and check that the front planetary gear turns smoothly when rotated counterclockwise and that it locks securely when rotated clockwise.

University of Cambridge

## 12. REAR PLANETARY GEAR AND OUTPUT SHAFT DISASSEMBLY AND REASSEMBLY

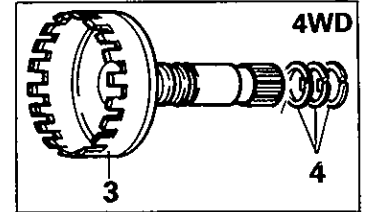
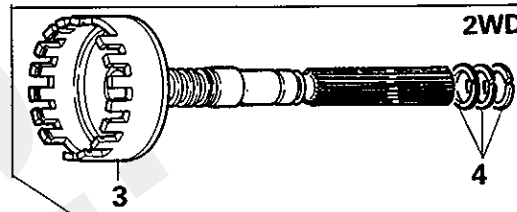
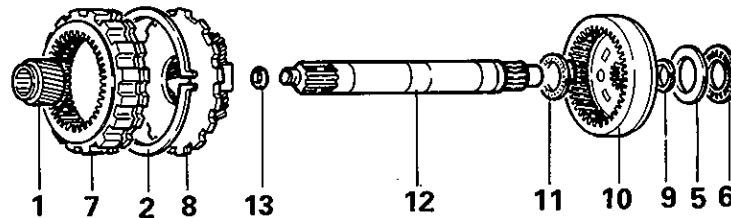

### Disassembly steps

- |   |   |
|---|---|
| <p>◆◆ 1. Planetary sun gear<br/>◆◆ 2. Retaining ring<br/>◆◆ 3. Output shaft assembly<br/>◆◆ 4. Seal ring<br/>◆◆ 5. Thrust bearing race #17<br/>◆◆ 6. Thrust bearing #18<br/>◆◆ 7. Front planetary ring gear<br/>◆◆ 8. Rear planetary gear</p> | <p>◇◇ 9. Split ring<br/>◇◇ 10. Rear planetary ring gear<br/>◇◇ 11. Thrust bearing #16<br/>◇◇ 12. Intermediate shaft<br/>◇◇ 13. O-ring</p> |
|---|---|

TRA0392

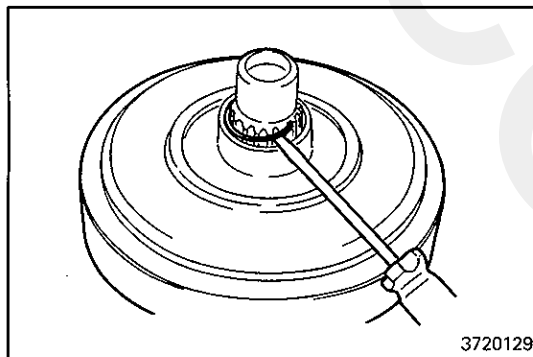

### SERVICE POINT OF DISASSEMBLY

#### ◇◇ REMOVAL OF SPLIT RING

- (1) Remove the split ring using a screwdriver as shown.

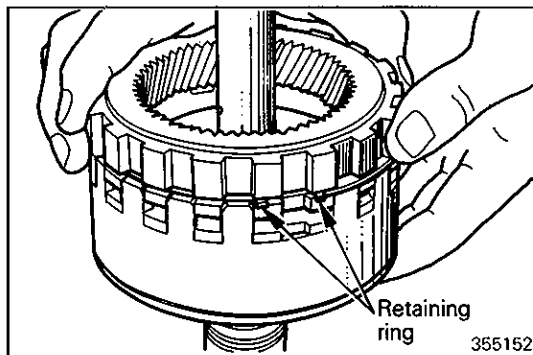

### SERVICE POINT OF REASSEMBLY

#### ◆◆ INSTALLATION OF RETAINING RING

- (1) Install the snap ring on the front planetary ring gear.  
 (2) Set the front planetary ring gear on the output shaft drum. Align the ends of the snap ring with the wide gap between the teeth.  
 (3) While pushing down the front planetary ring gear, squeeze the snap ring ends to install it into the groove.

University of Cambridge

### 13. BRAKE NO. 3 PISTON DISASSEMBLY AND REASSEMBLY

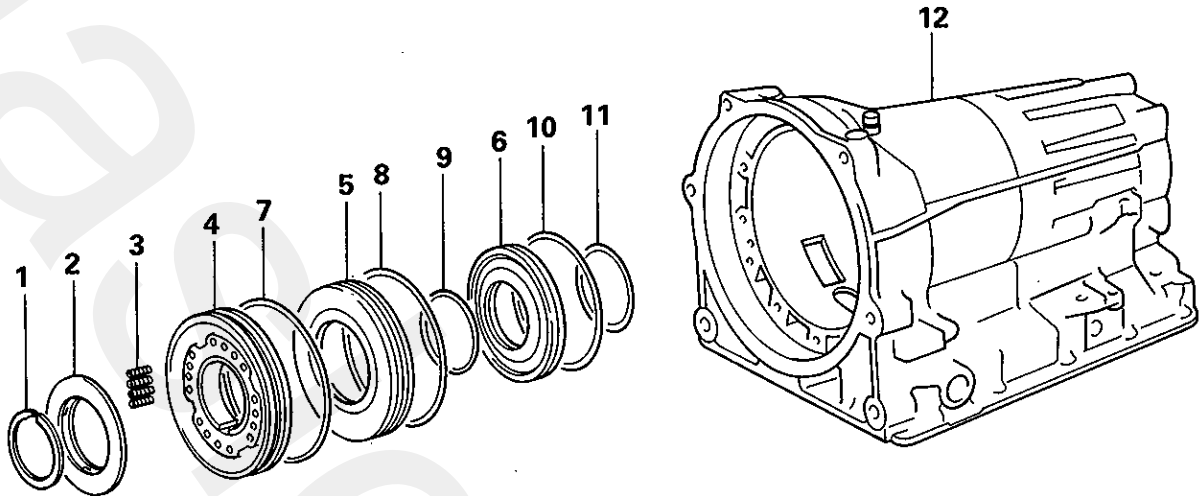

**Disassembly steps**

- |  |  |
|--|--|
| <p>(A) (A) 1. Snap ring<br/>2. Spring retainer<br/>3. Spring</p> <p>(B) 4. Brake No. 3 primary piston<br/>(B) 5. Reaction sleeve<br/>(B) 6. Brake No. 3 secondary piston</p> | <p>7. O-ring<br/>8. O-ring<br/>9. O-ring<br/>10. O-ring<br/>11. O-ring<br/>12. Transmission case</p> |
|--|--|

**NOTE:**  
Depending on the model and year model, the spring retainer (2) may be integrated with spring (3).

3720353

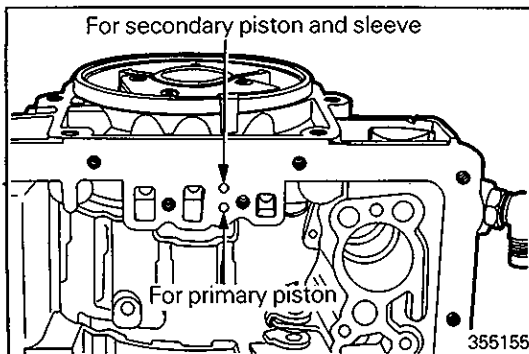
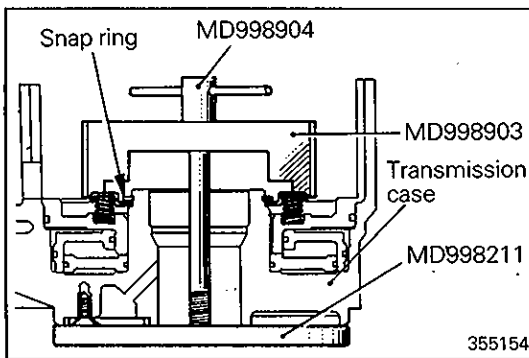

**SERVICE POINT OF DISASSEMBLY**

**(A) REMOVAL OF SNAP RING**

- (1) Compress the spring and remove the snap ring by using the special tools.

**(B) REMOVAL OF PRIMARY PISTON, REACTION SLEEVE AND SECONDARY PISTON**

- (1) With the front end down, place the transmission case on a workbench. Place several clean shop rags under the case to catch the piston and sleeve. Apply compressed air to the primary and secondary piston oil holes to force the piston and sleeve out.

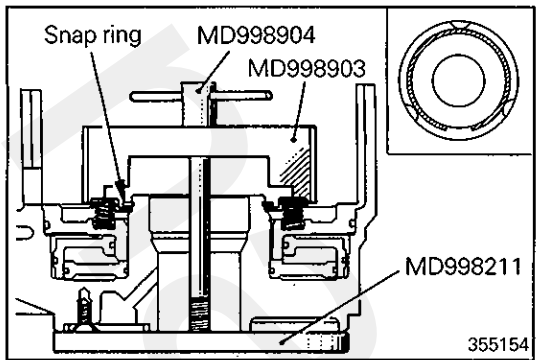

## SERVICE POINT OF REASSEMBLY

### **A** INSTALLATION OF SNAP RING

- (1) Compress the springs and fit the snap ring by using the special tools.
- (2) Push the snap ring by hand into place. Visually check to make sure it is fully seated and centered by the three lugs on the spring retainer.

**14. GOVERNOR****DISASSEMBLY AND REASSEMBLY****Disassembly steps**

1. E-ring
  2. Governor weight
  3. Governor valve shaft
  4. Secondary weight
  5. Inner governor spring
  6. Outer governor spring
  7. Governor valve
  8. Governor retaining ring
  9. Governor body
- A B  
A

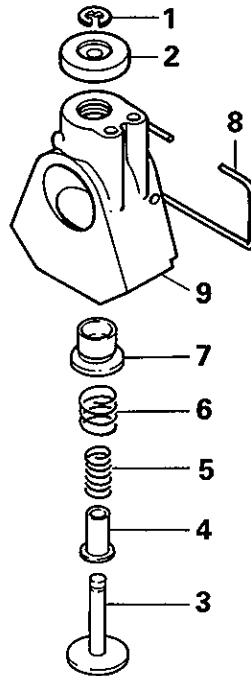

372066

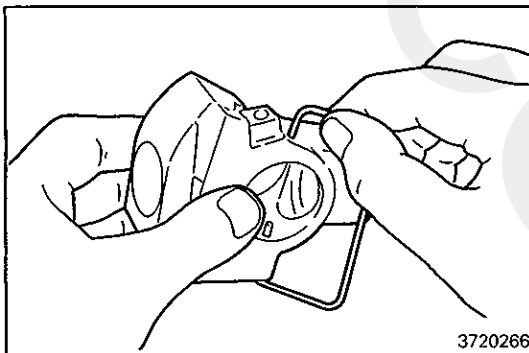

3720266

**SERVICE POINT OF DISASSEMBLY****A REMOVAL OF GOVERNOR RETAINING RING**

- (1) Remove the governor retaining ring with its end which is not through the governor body first. Use care not to damage the governor body.

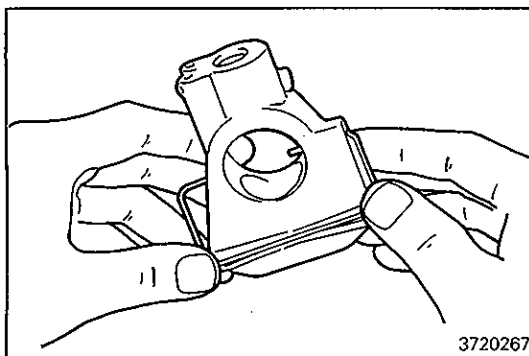

3720267

**SERVICE POINT OF REASSEMBLY****A INSTALLATION OF GOVERNOR RETAINING RING**

- (1) Fit the end of the governor retaining ring which goes through the governor body first.

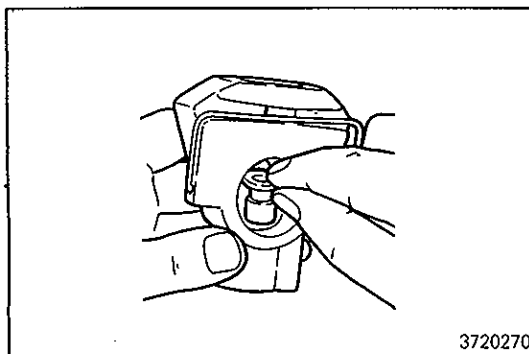

3720270

**B INSTALLATION OF GOVERNOR VALVE**

- (1) Insert the governor valve into the hole in the output shaft with care not to damage the governor valve.

University of Cambridge



# 15. VALVE BODY DISASSEMBLY AND REASSEMBLY

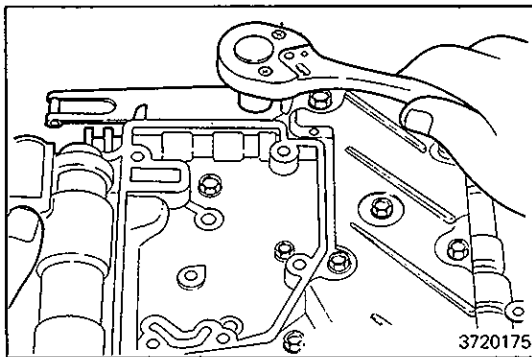
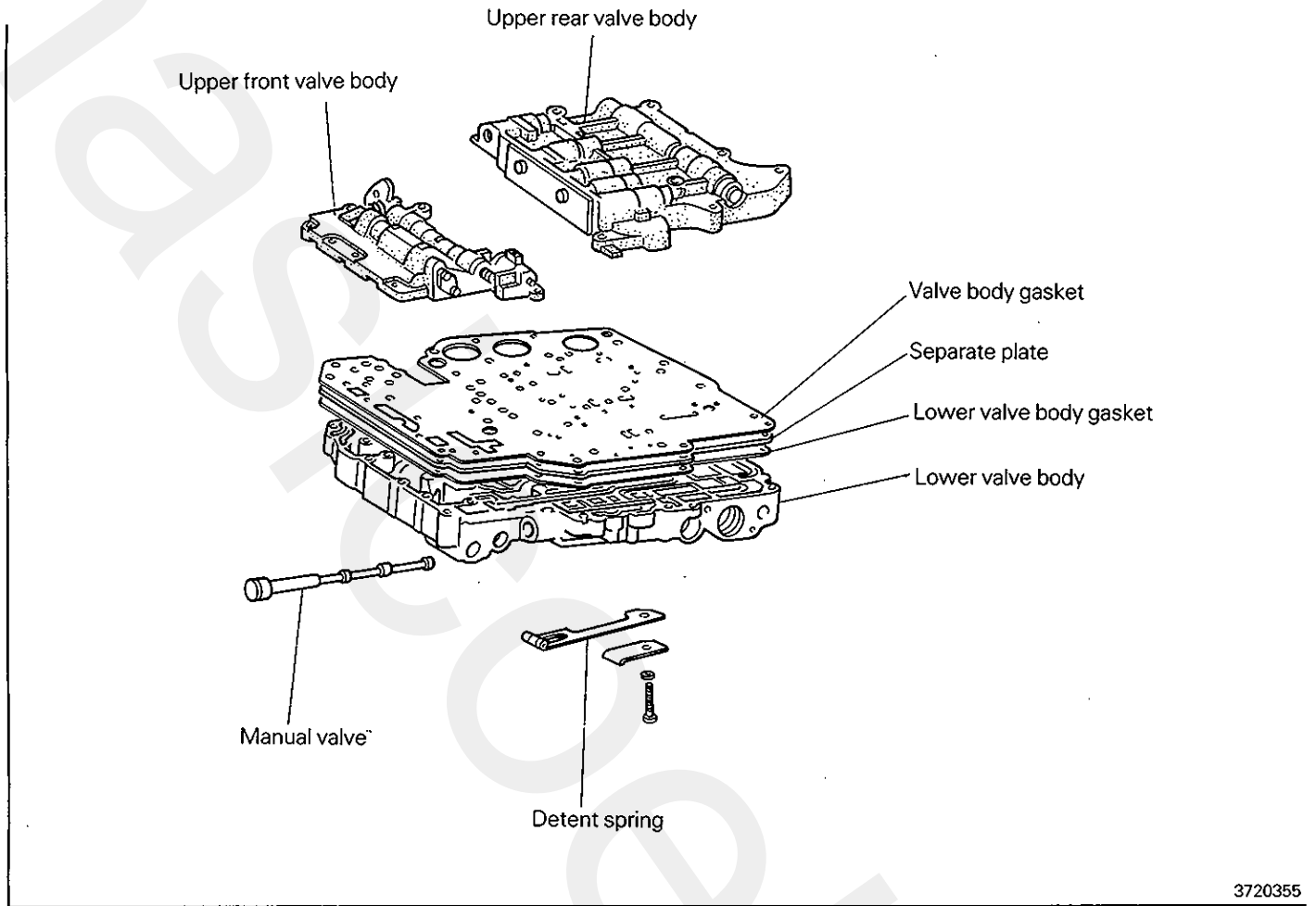

## DISASSEMBLY

- (1) Remove the detent spring.
- (2) Remove the manual valve.

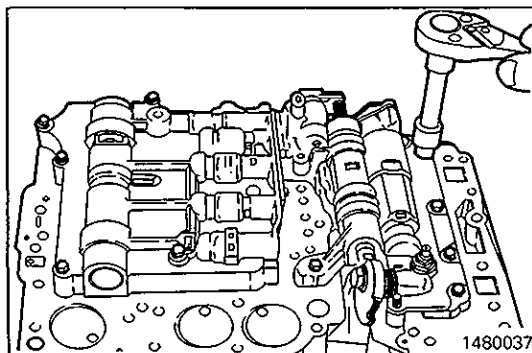

- (3) Turn the valve body assembly upside down and remove the 10 bolts from the upper front and upper rear valve bodies.

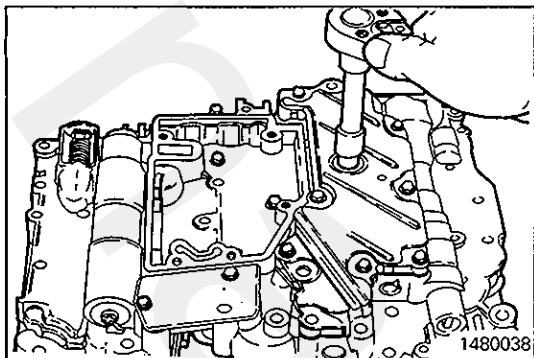

- (4) Turn over the assembly and remove the set bolts from the lower valve body.

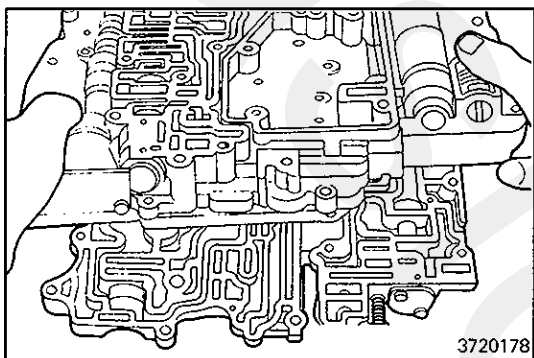

- (5) Remove the lower valve body and plate by lifting them up together.

**Caution**

- Use care not to drop the check valve and ball.

**DIFFERENCE BETWEEN TWO TYPES OF VALVE BODIES**

The valve body assembly of the transmission with lockup clutch differs from that of the transmission without lockup clutch as indicated by arrow in the following illustration.

**With lockup clutch**

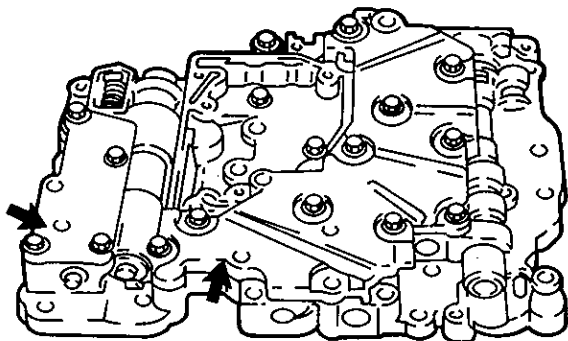

**Without lockup clutch**

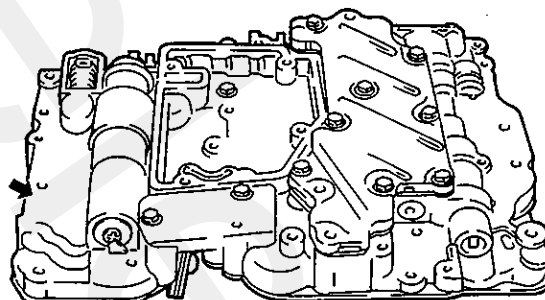

TRA0393

1480049

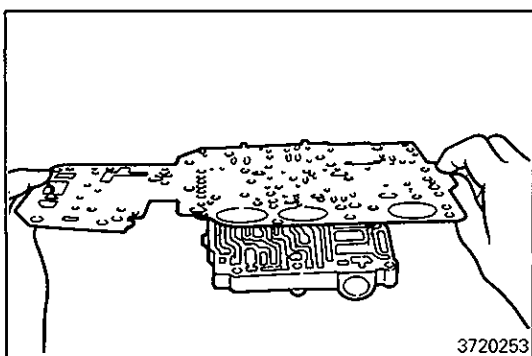

**REASSEMBLY**

- (1) Put a new gasket on the upper rear valve body. Before installations, make sure that the new gasket matches with the old gasket. Align the gasket with the lower right-hand corner.

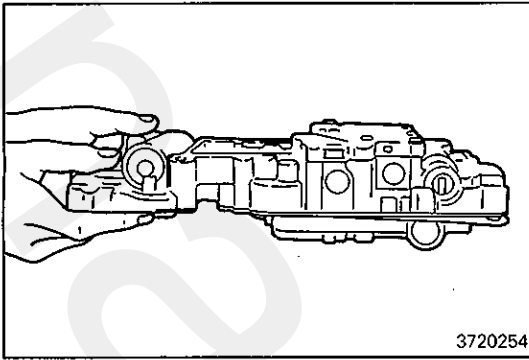

(2) Place the lower valve body with plate on the upper rear valve body with the R.H. side corners in alignment.

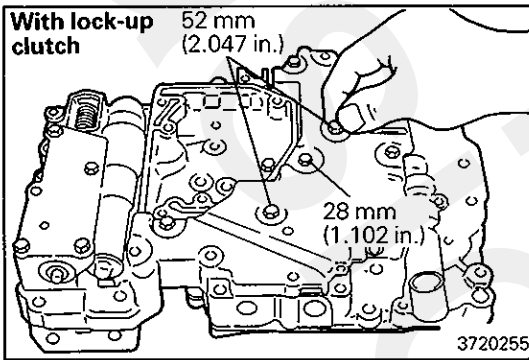

(3) Use three bolts to loosely tighten the upper rear valve body to the lower valve body.

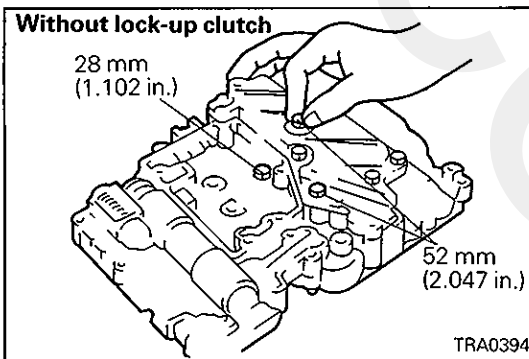

(4) Turn the valve body assembly upside down, check the gasket for alignment and then tighten the five bolts in the upper rear valve body.

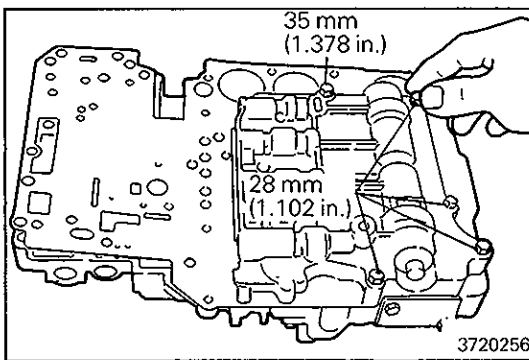

(5) Remove the loosely tightened bolt from the plate.

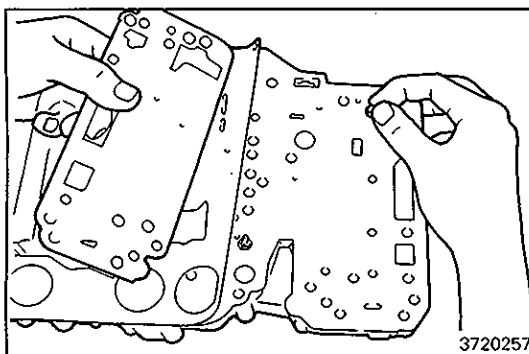

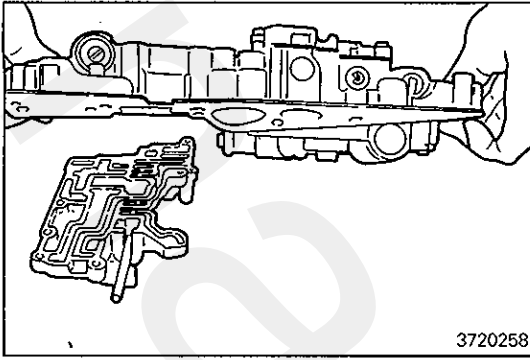

- (6) Put the lower and upper rear valve body assemblies on the upper front valve body.

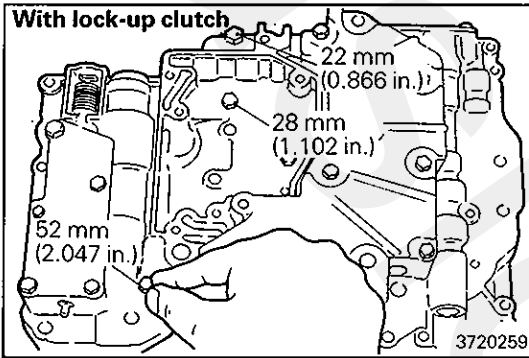

- (7) Tighten the lower valve body set bolts by hand to secure the upper front valve body.

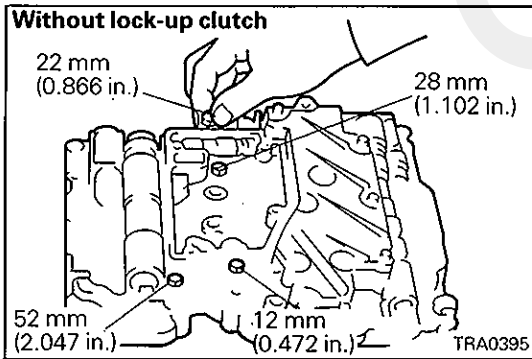

- (8) Turn the valve body assembly upside down and tighten the five bolts in the upper front valve body by hand.

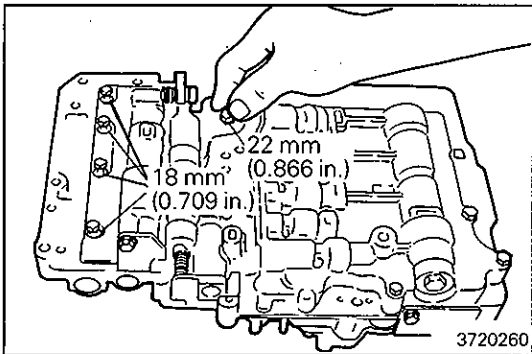

- (9) Make sure again that the gaskets are in alignment. Tighten the upper front valve body and upper rear valve body bolts to specified torque.

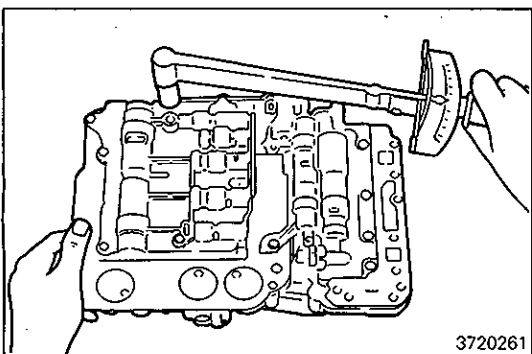

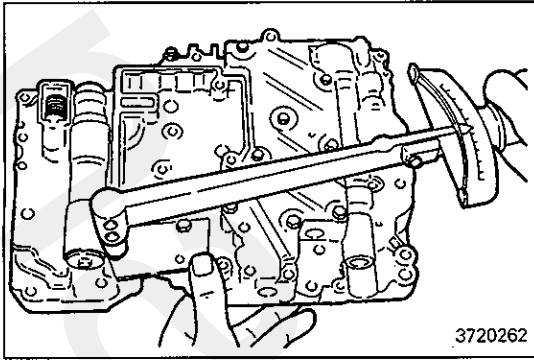

(10) Turn over the assembly and tighten the lower valve body bolts to specified torque.

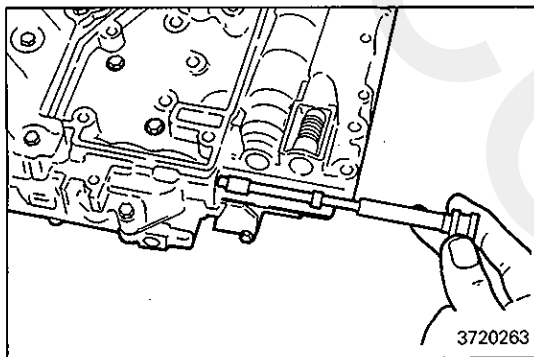
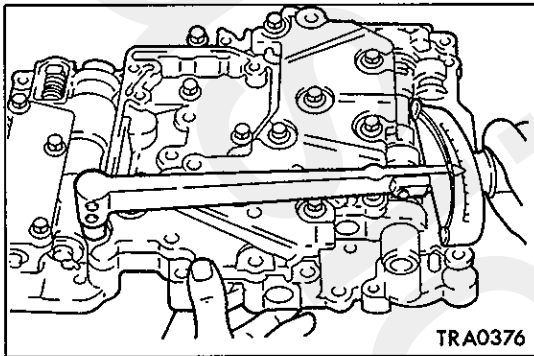

(11) Insert the manual valve in the valve body.

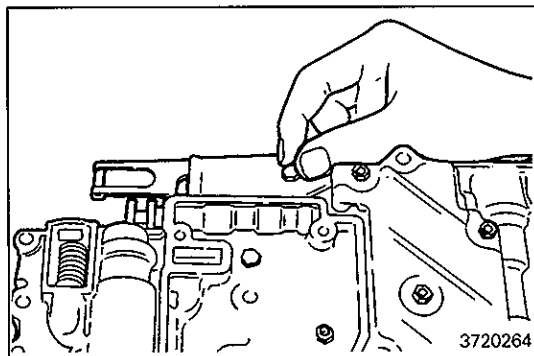

(12) Install the detent spring and tighten the bolts to specified torque.

**LOWER VALVE BODY  
DISASSEMBLY AND REASSEMBLY**

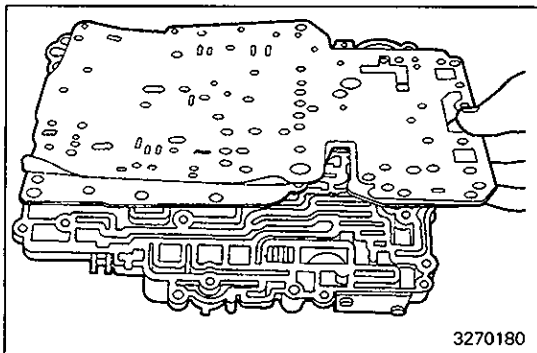
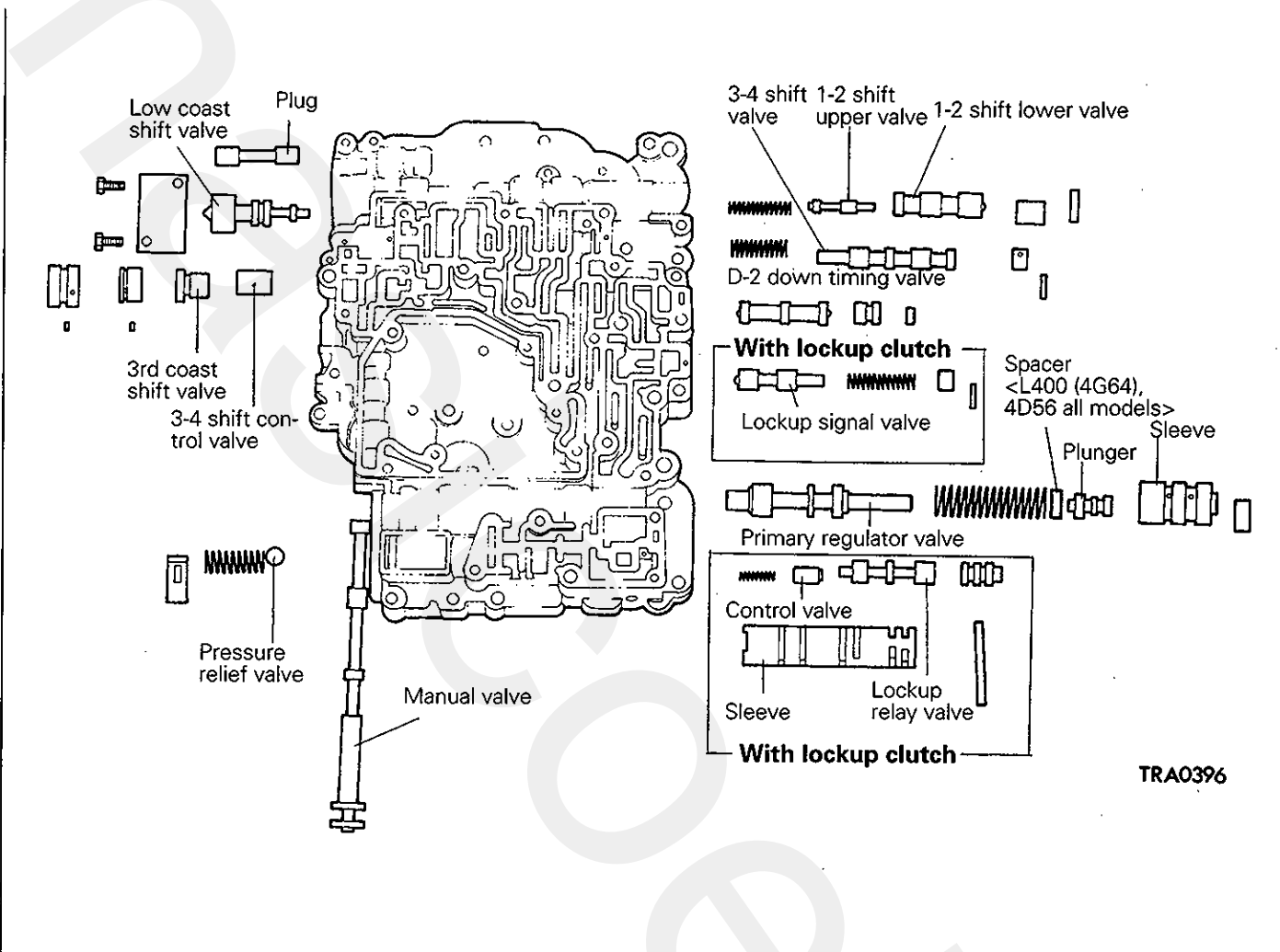

**DISASSEMBLY**

(1) Remove the lower valve body plate and gaskets.

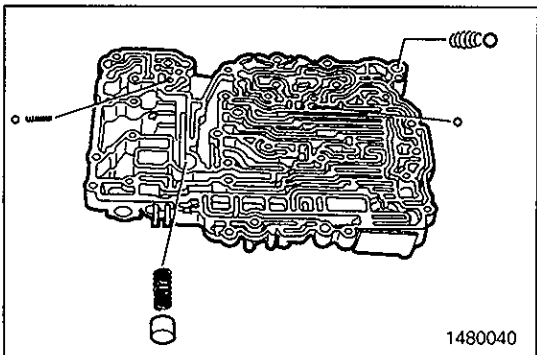

(2) Remove the check balls, damping check ball, spring, oil cooler return ball, spring, oil cooler bypass valve and spring.

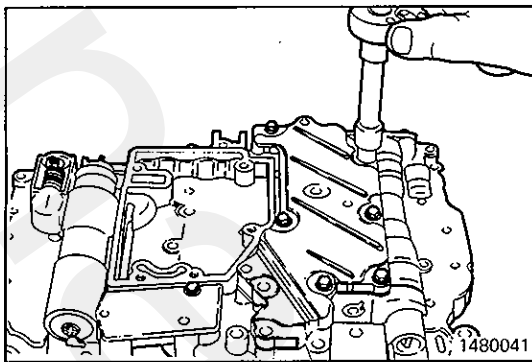

- (3) Turn the assembly upside down, remove the set bolts and remove the lower valve body cover, plate and gasket.

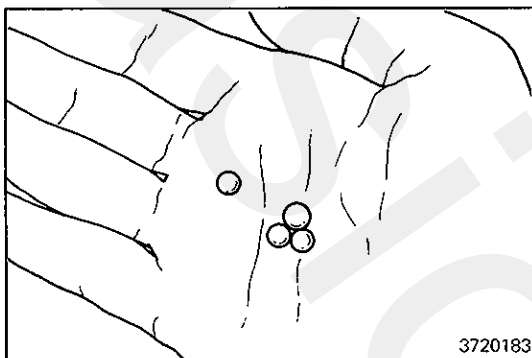

- (4) Remove the four check balls, using care not to damage the grooves. Store the balls together so as not to lose any of them.

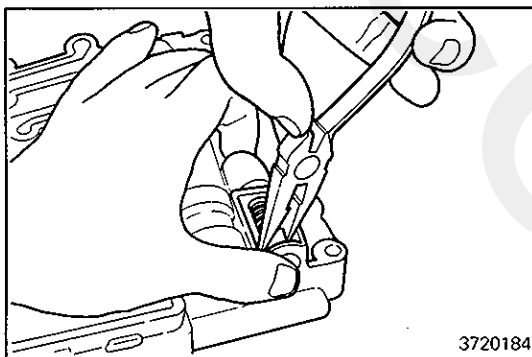

- (5) Remove the retainer from the pressure relief valve assembly.

**Caution**

- **Cover the spring with a hand. Then, use long nose pliers to pull out the spring seat while exercising care not to bend the spring.**

- (6) Remove the pressure relief valve spring and ball.

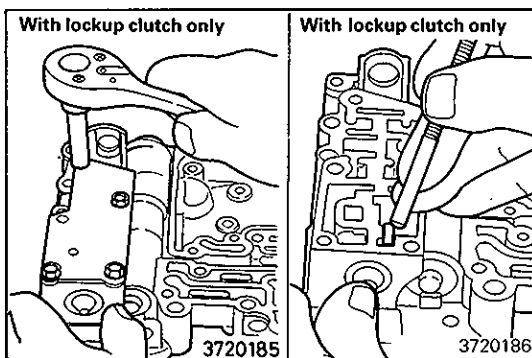

- (7) Remove the plate and gasket. (With lockup clutch only)

- (8) Remove the lockup relay valve. (With lockup clutch only)

- (a) Remove the plug retainer and plug.

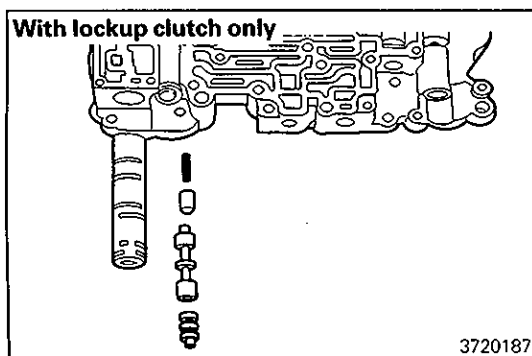

- (b) Remove the sleeve together with the lockup relay valve, control valve and spring.

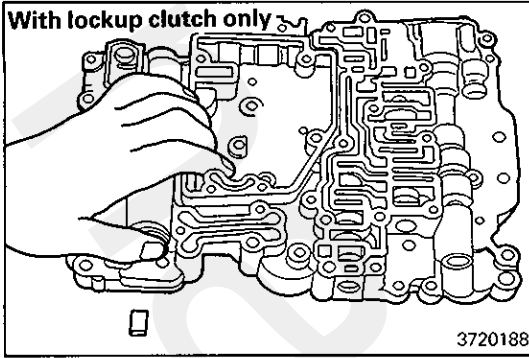

- (9) Remove the valve retainer from the primary regulator valve. (With lockup clutch only)

**Caution**

- Since the primary regulator valve contains a fully compressed spring, do not bring your face close to it.

To remove the retainer, hold the primary regulator valve with its valve body side surface down. Then press in the valve sleeve, and the retainer will drop off. Release the spring slowly.

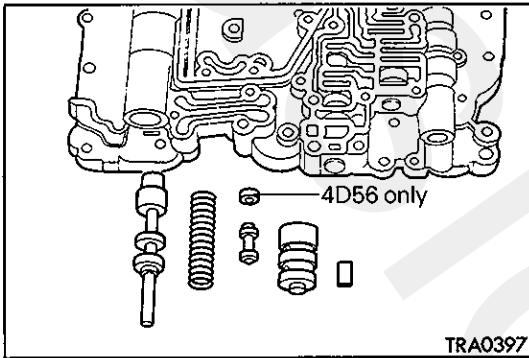

- (10) Remove the sleeve, plunger, spring and primary regulator valve.

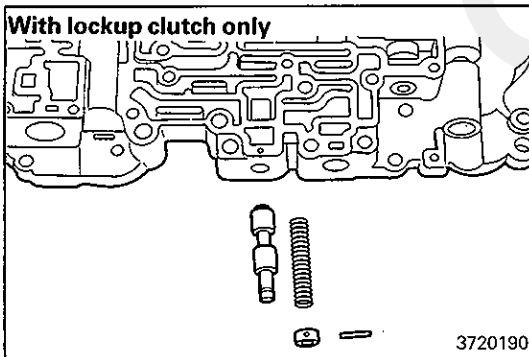

- (11) Remove the locating pin from the lockup signal valve. (With lockup clutch only)

- (12) Remove the plug, spring and lockup signal valve. (With lockup clutch only)

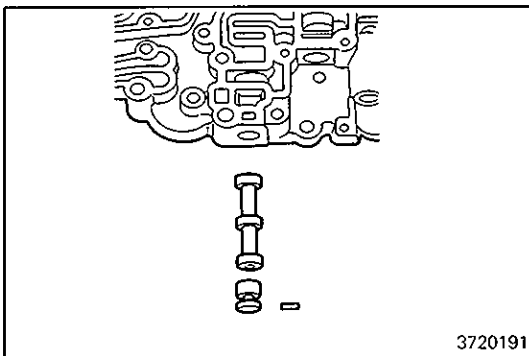

- (13) Remove the valve retainer from the D-2 down timing valve.

- (14) Remove the plug and D-2 down timing valve.

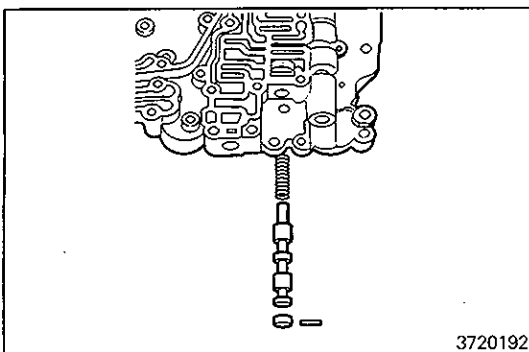

- (15) Remove the locating pin from the 3-4 shift valve.

- (16) Remove the plug, 3-4 shift valve and spring.



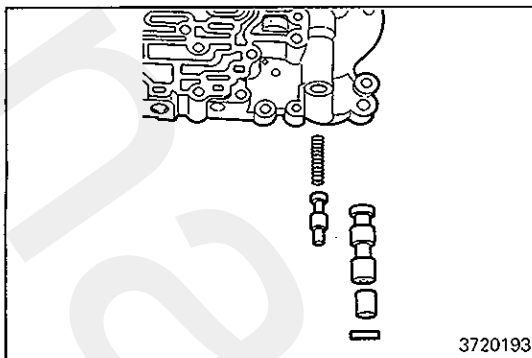

- (17) Remove the valve retainer from the 1-2 shift valve.
- (18) Remove the plug, 1-2 shift valve and spring.

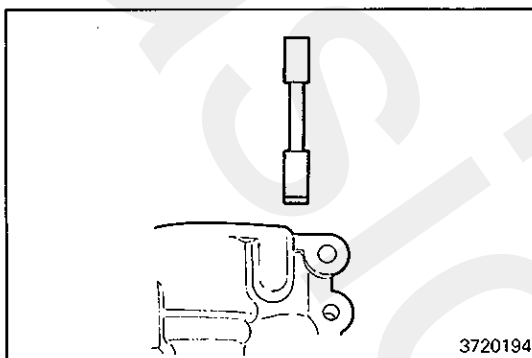

- (19) Remove the cover plate.
- (20) Remove the plug.

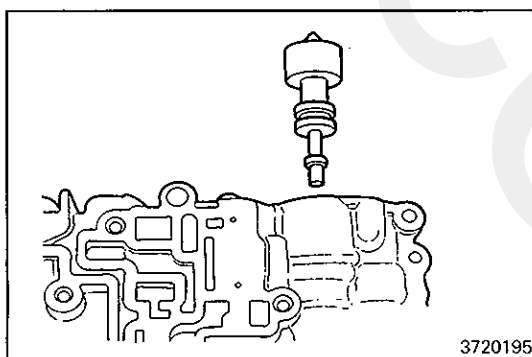

- (21) Remove the low-coast shift valve.

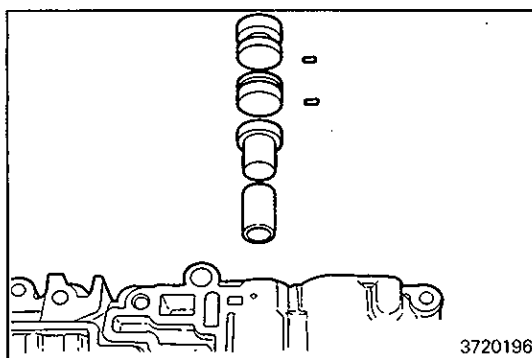

- (22) Remove the locating pins from the 3rd-coast shift valve.
- (23) Remove the two plugs, 3rd-coast shift valve and 3-4 shift control valve.

**INSPECTION  
VALVE SPRING**

Check the spring for damage, rust and permanent set. Measure the free length of the spring. If it is below the standard value, replace the spring. (Refer to Spring Identification Table.)

**REASSEMBLY**

(1) Install the plug.

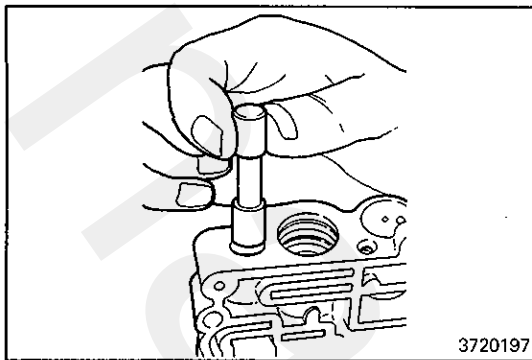

(2) Insert the low-coast shift valve carefully with its small end down.

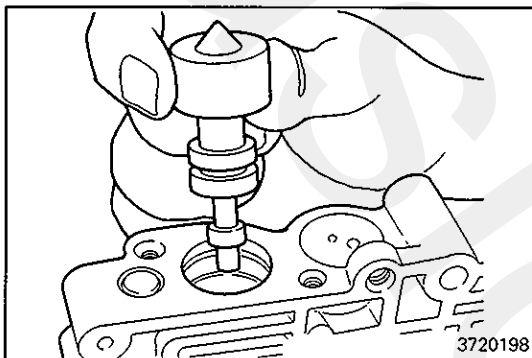

(3) Install the 3-4 shift control valve and 3rd-coast shift valve as follows:

- (a) Insert the 3-4 shift control valve with its cup side down.
- (b) Insert the 3rd-coast shift valve with its small end down.

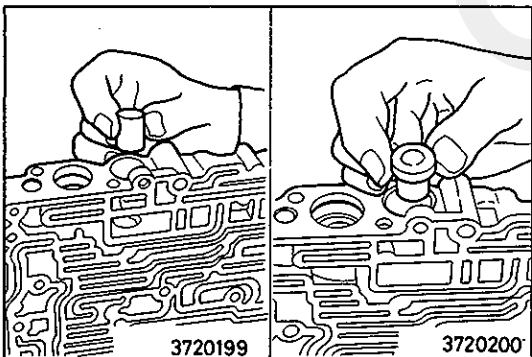

(4) Insert two plugs and locating pins.

- (a) Insert the 3rd-coast shift valve inside plug with its thick face side down.
- (b) Use long nose pliers to insert the locating pin.
- (c) Insert the outside plug and then the locating pin.

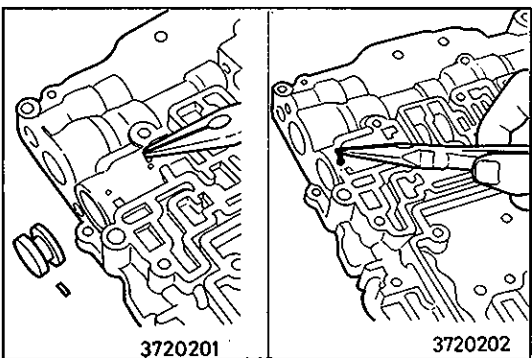

(5) Install the low-coast shift valve cover.

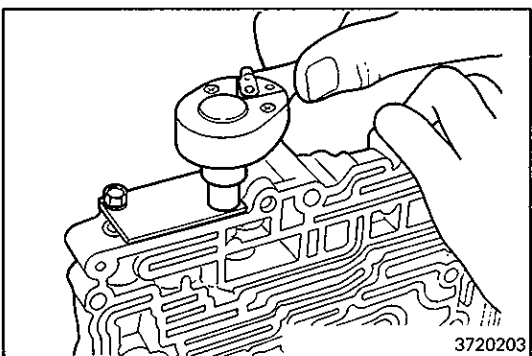

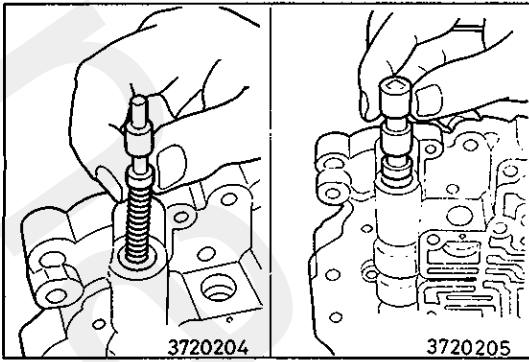

- (6) With the valve body held vertically, insert the spring, 1-2 upper and lower shift valves and plug in the valve body.
- (7) Install the valve retainer to the 1-2 shift valve.

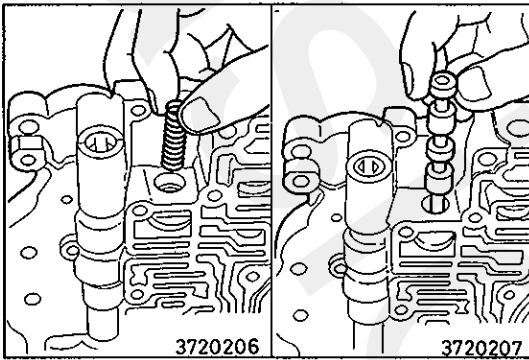

- (8) With the valve body held vertically, insert the spring, 3-4 shift valve (with the small end held down) and plug carefully.
- (9) Install the 3-4 shift valve locating pin.

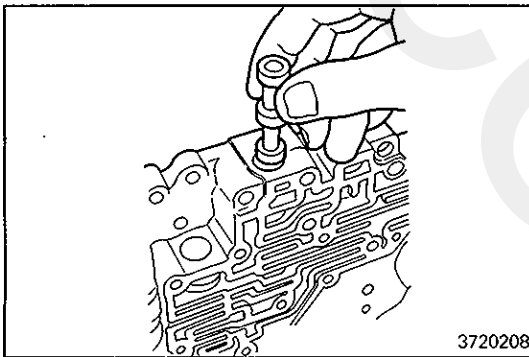

- (10) Insert the small end of the D-2 down timing valve first. Then insert it in the big end of the plug.
- (11) Install the valve retainer to the D-2 down timing valve.

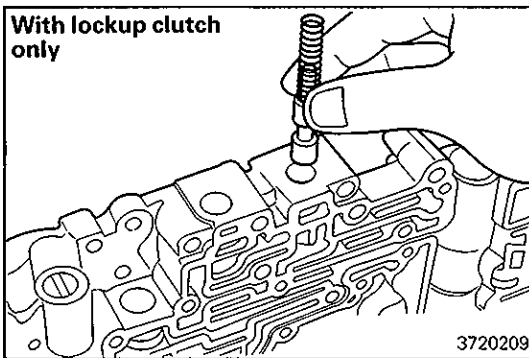

- (12) Install the lockup signal valve (with its big end down), spring and plug (with its small end down). (With lockup clutch only)
- (13) Install the lockup signal valve locating pin. (With lockup clutch only)

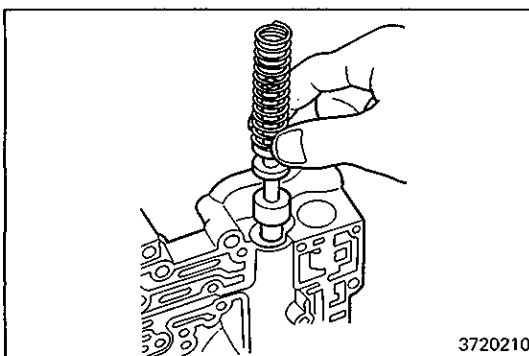

- (14) Insert the primary regulator valve and spring.

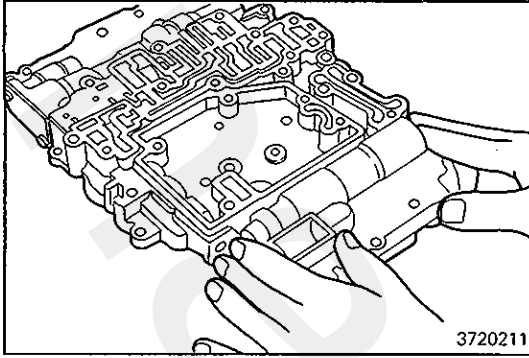

3720211

(15) Make sure that the valve is properly located.

## NOTE

Be sure to see that the primary regulator valve surface is flush with the valve body surface.

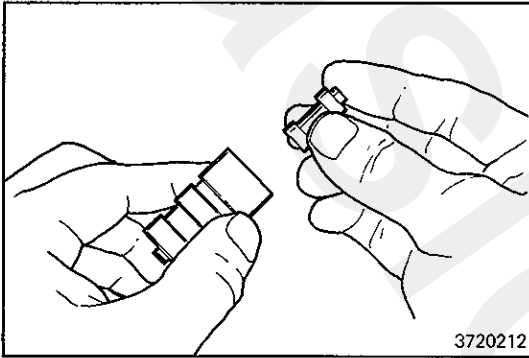

3720212

(16) Insert the primary regulator valve plunger in the sleeve.  
Be sure to insert the rounded end first and make sure that the plunger is fully inserted until it is drawn into the sleeve.

(17) Insert the sleeve together with the plunger.

(18) Install the valve retainer.

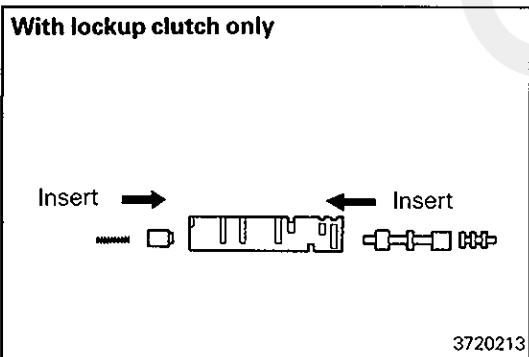

3720213

(19) Insert the lockup relay valve as follows:

(With lockup clutch only)

(a) Assemble the spring, lockup relay control valve, lockup relay valve and plug to the sleeve.

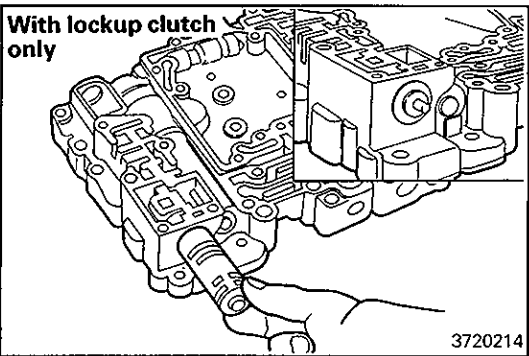

3720214

(b) Insert the sleeve in the hole.

## NOTE

Be sure to insert the sleeve with its smaller void up as shown in the illustration.

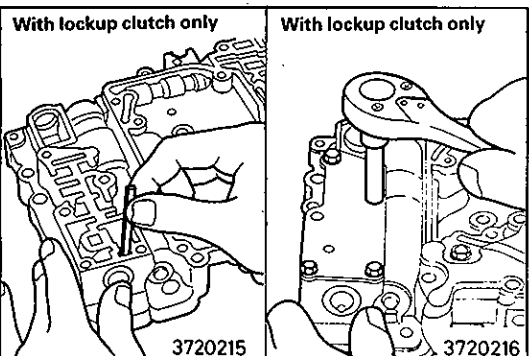

3720215

3720216

(c) Install the plug retainer.

(20) Install the plate together with the gasket and tighten the four bolts. (With lockup clutch only)

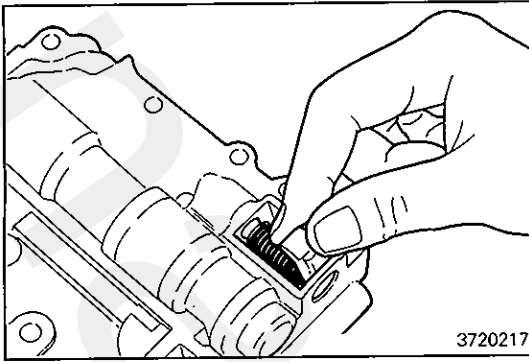

(21) Install the pressure relief valve, spring and retainer.

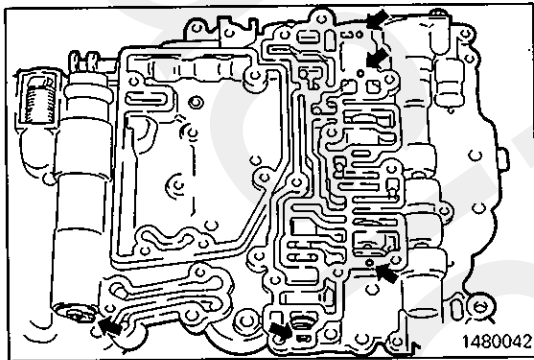

(22) Check the retainer and locating pin to make sure that the retainer and pin are properly installed.

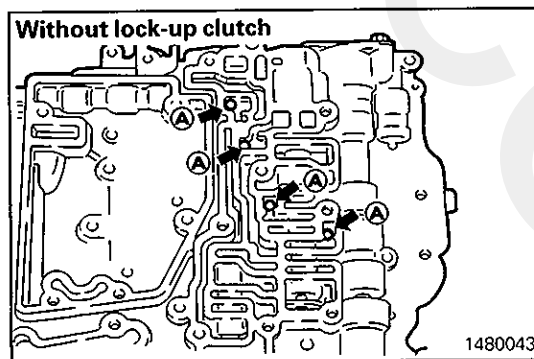

(23) Install the three or four check balls.

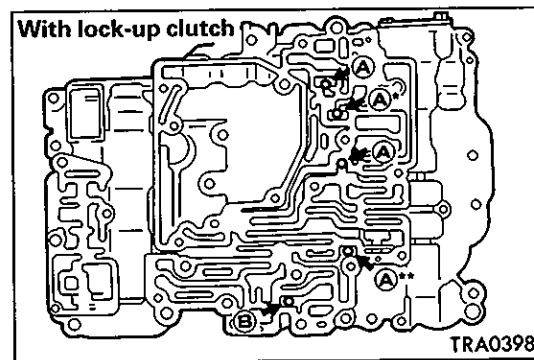

Check ball **A**: Diameter 5.5 mm (0.216 in.)

Check ball **B**: Diameter 6.4 mm (0.252 in.)

\*: Pajero/Montero, L300 for EXP, AUS

\*\* : 6G72 for EC

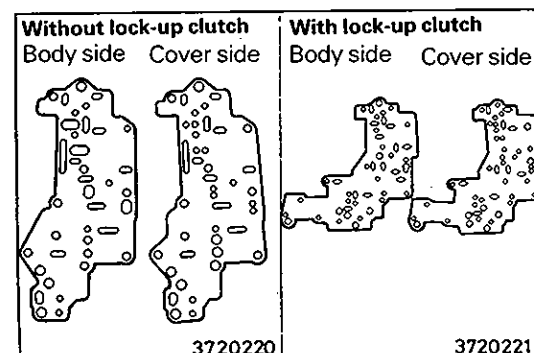

(24) Install the lower valve body cover by the following sequence.

Gasket (body side) → plate → gasket (cover side) → cover

NOTE

The upper gasket is not interchangeable with the lower gasket.

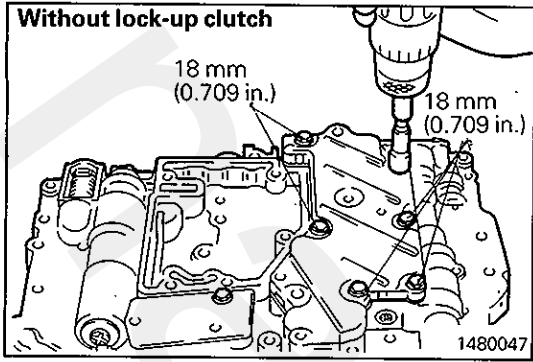

(25) Install the lower valve body cover set bolts.

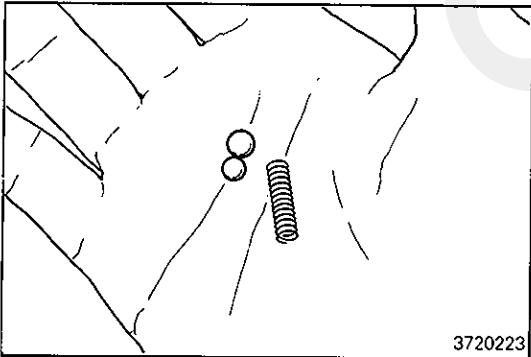
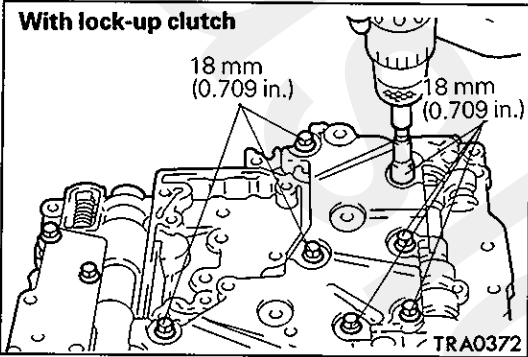

(26) Identify the check balls and springs.  
Note that the two rubber check balls differ in size. A larger ball is installed on the damping side of the spring.

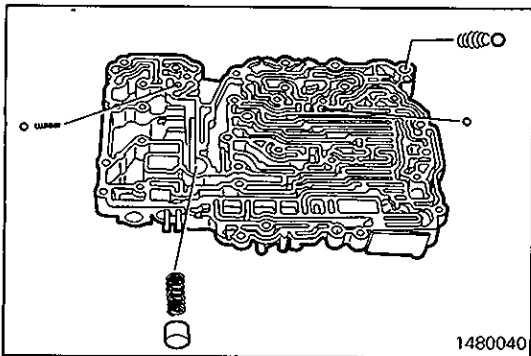

(27) Install the check ball, damping check ball, spring, oil cooler return ball, spring, oil cooler bypass valve and spring.

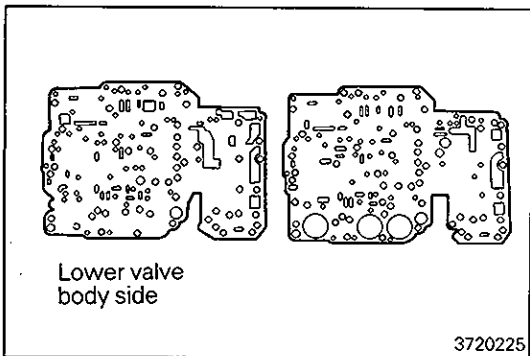

(28) Install the valve body gaskets.  
The two gaskets are not interchangeable with each other.

**Caution**

- When replacing the gasket, make sure that a new gasket matches with the old gasket.

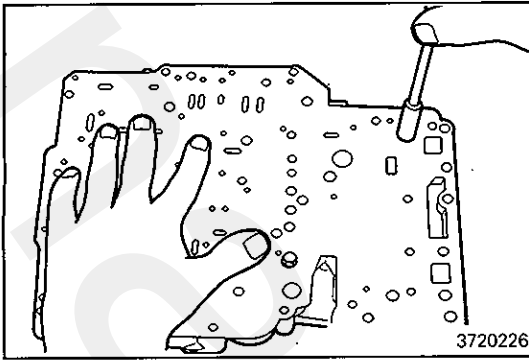

- (29) Install the separator plate.  
 Set the plate in the specified location.  
 Finger tighten the two oil strainer mounting bolts so that the check valve floated by spring force may be held by the plate.

**UPPER FRONT VALVE BODY  
 DISASSEMBLY AND REASSEMBLY**

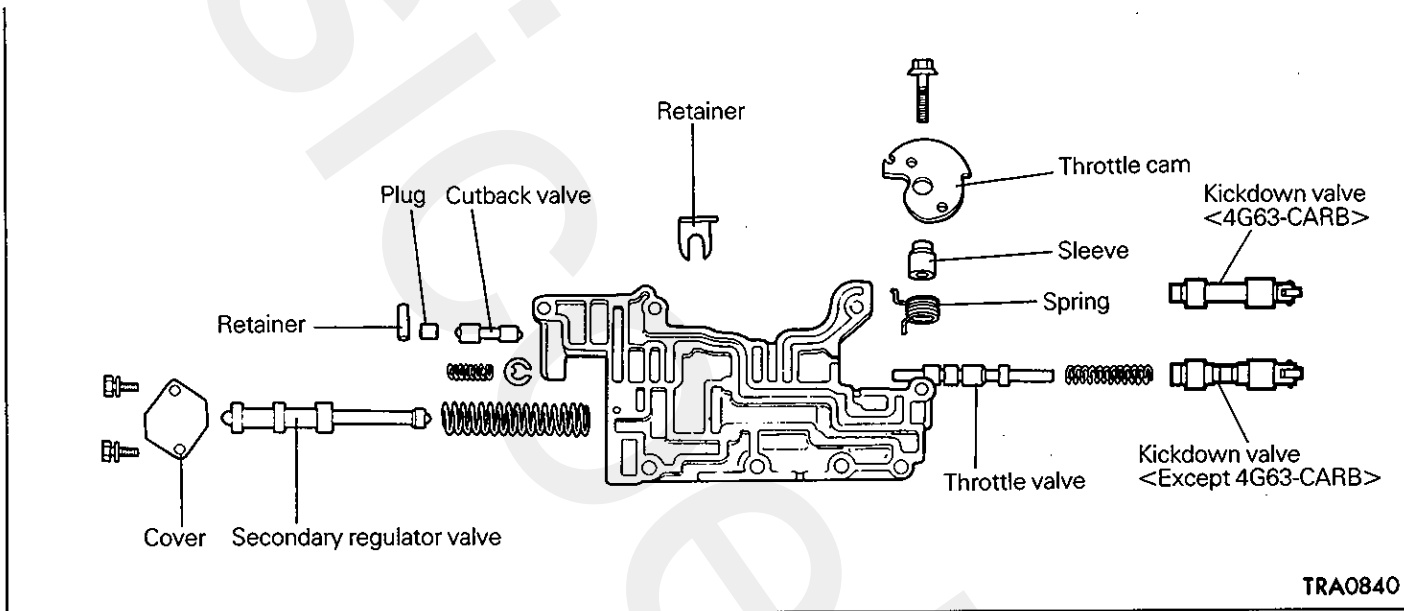

TRA0840

**DISASSEMBLY**

- (1) Remove the retainer, plug and cutback valve.

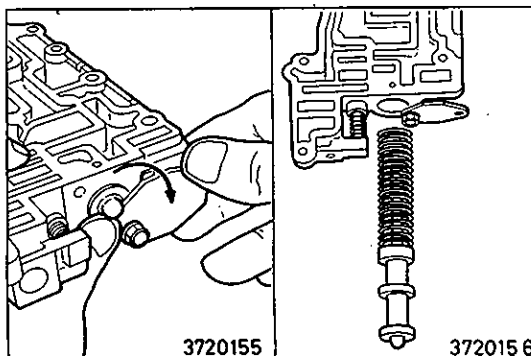
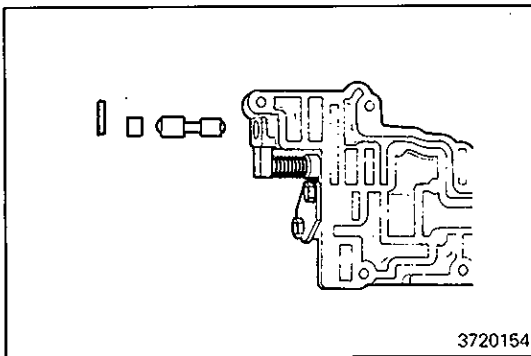

- (2) Remove the secondary regulator valve and spring as follows:

- (a) Remove one cover mounting bolt and loose the other bolt slightly. Rotate the cover slowly until the valve is visible, and hold with a finger.

**Caution**

- As the spring has a strong force, be sure to prevent the valve from jumping out.

- (b) Remove the valve and spring.  
 (c) Remove the bolt and cover.

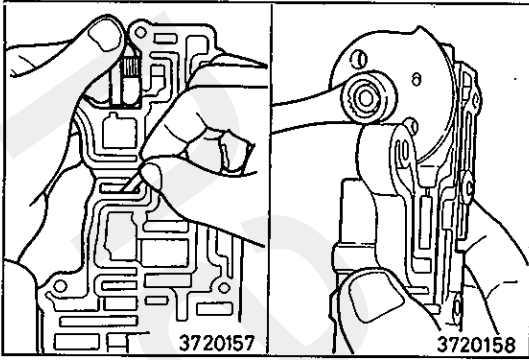

- (3) Rotate the throttle cam, press-fit the downshift plug into the valve body, insert the cutback valve plug retainer in the illustrated position and hold the throttle valve.
- (4) Remove the throttle cam spring.

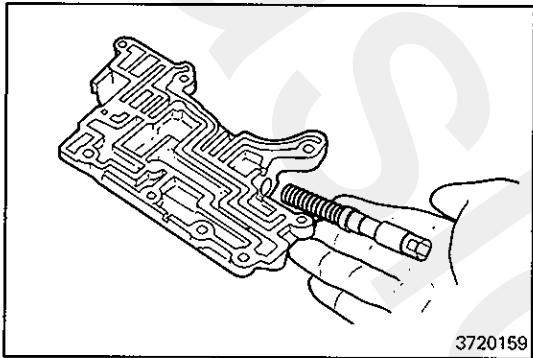

- (5) Pull out the retainer inserted in (3) above and remove the downshift plug and spring.

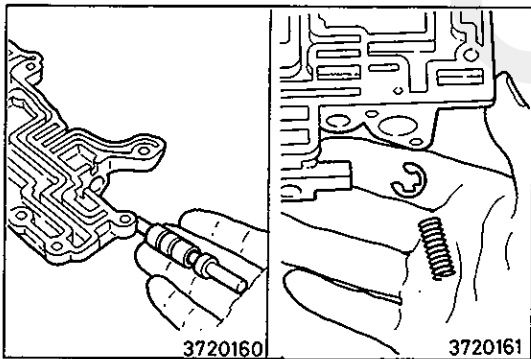

- (6) Pull out the throttle valve retainer and remove the throttle valve and spring.

### INSPECTION

- (1) Check the valve spring for damage, rust and permanent set. Measure the free length of the spring. If it is below the standard value, replace the spring. (Refer to Spring Identification Table.)

### REASSEMBLY

- (1) Insert the throttle valve fully in the hole made in the valve body.
- (2) Coat the throttle valve retainer with petrolatum and insert it in the illustrated position.

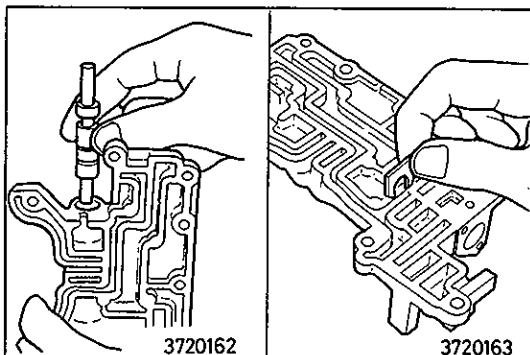



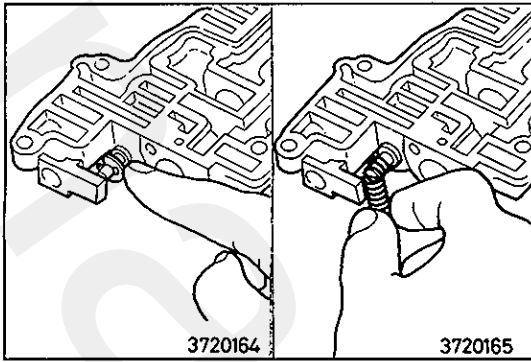

(3) Install the spring to the end of the throttle valve.

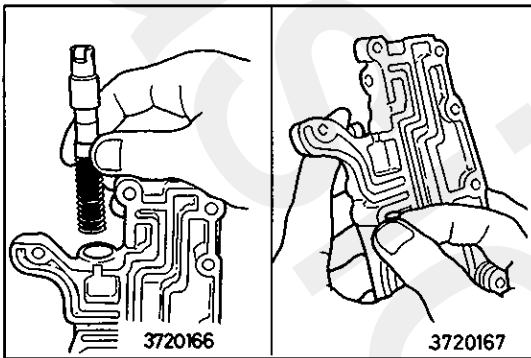

(4) Install the spring and downshift plug.  
 (5) Press-fit the downshift plug and insert the cutback valve plug retainer in the illustrated location.

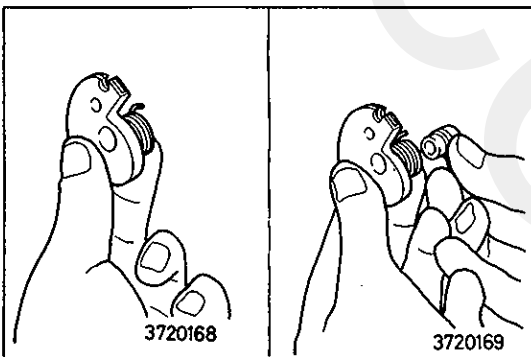

(6) Install the spring with its end hooked to the hole made in the throttle cam.  
 (7) Insert the sleeve.

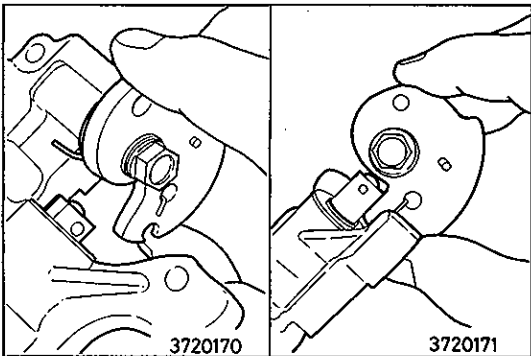

(8) Install the throttle cam to the valve body. Make sure that the spring end is properly hooked.  
 (9) Remove the valve plug retainer inserted in (5) above.

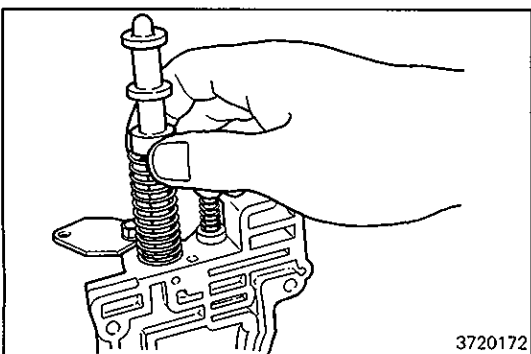

(10) Install the secondary regulator valve as follows:  
 (a) Use one bolt to install the cover.  
 (b) Install the spring and secondary regulator valve.  
 (c) Press-fit the valve and rotate the cover to close.  
 (d) Install the other bolt and tighten to specified torque.

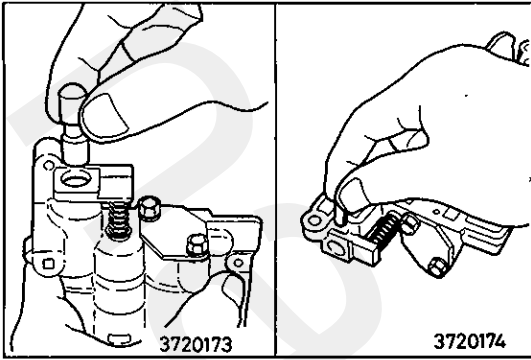

- (11) Insert the cutback valve and plug.
- (12) Coat the retainer with petrolatum and insert it in the illustrated location.

**UPPER REAR VALVE BODY  
DISASSEMBLY AND REASSEMBLY**

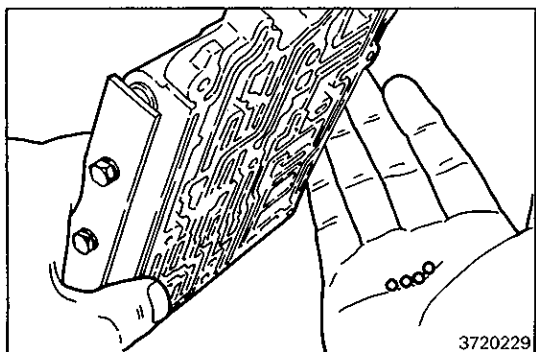
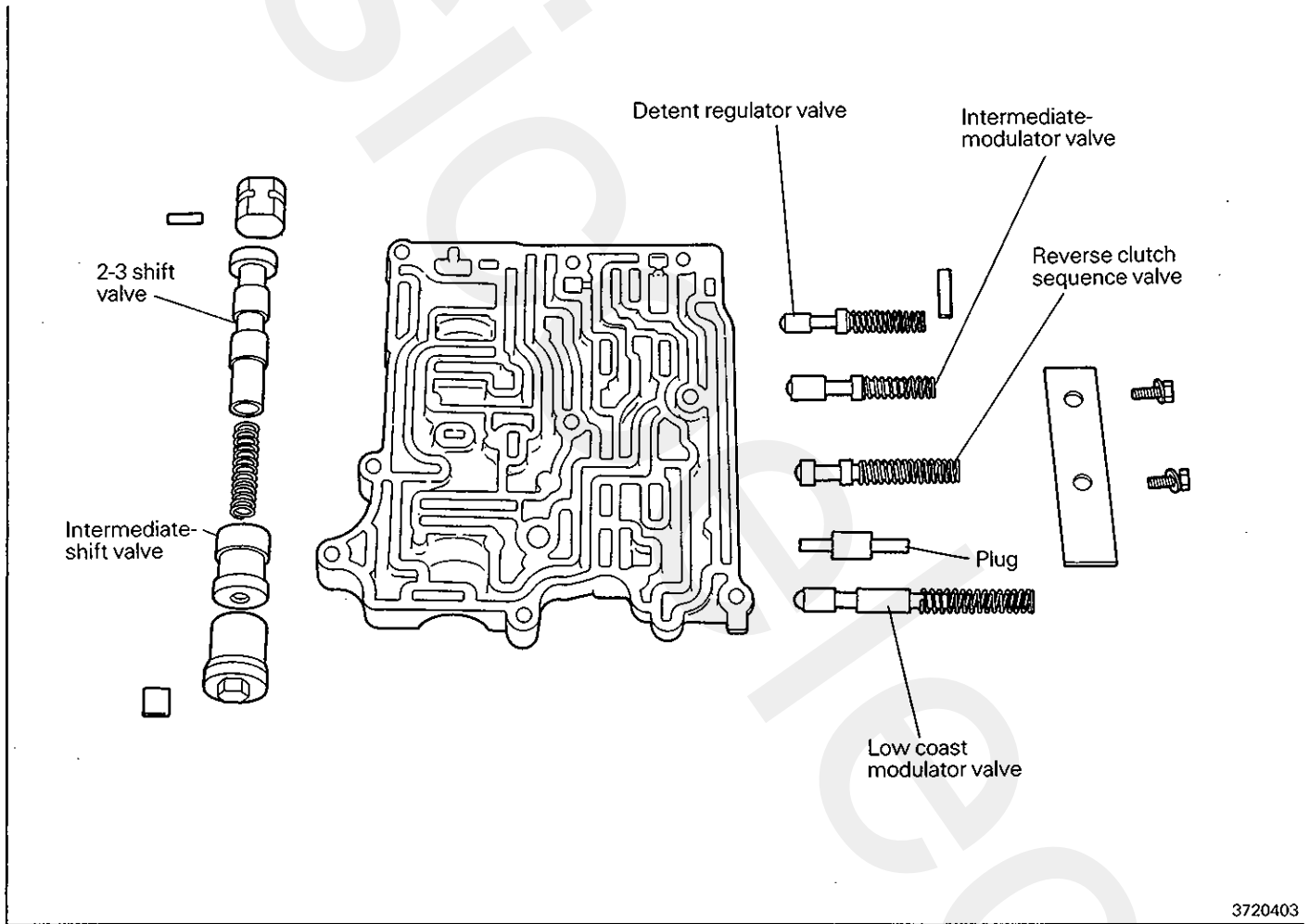

**DISASSEMBLY**

- (1) Use tweezers to remove the check balls (three rubber balls and one steel ball).

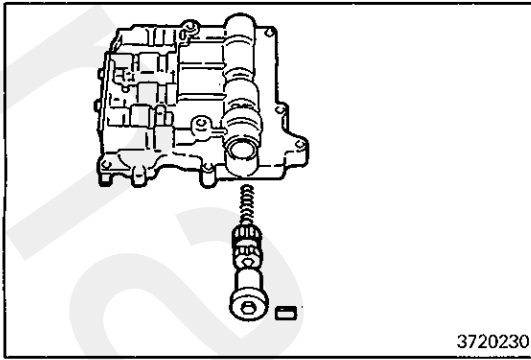

- (2) Remove the valve retainer from the intermediate-coast shift valve.
- (3) Remove the plug, intermediate-coast shift valve and spring.

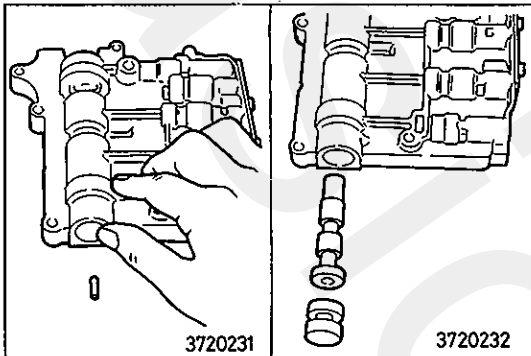

- (4) Remove the 2-3 shift valve as follows:
  - (a) Remove the valve retainer from the 2-3 shift valve.
  - (b) Remove the plug and 2-3 shift valve.

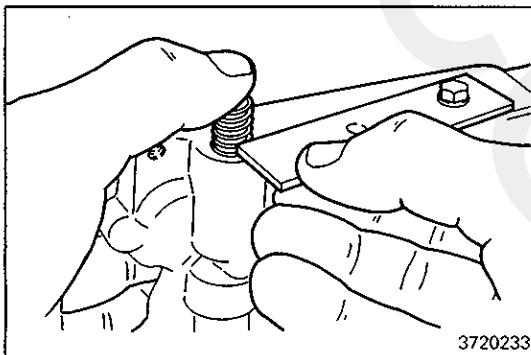

- (5) Of the two bolts, remove the one which is installed on the low-coast modulator valve side, from the rear valve cover.
- (6) Slide the cover slightly to remove the low-coast modulator valve only.

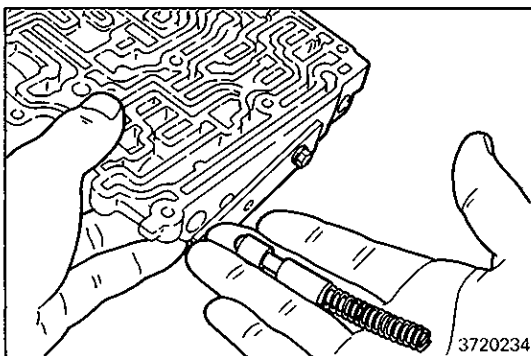

- (7) Remove the spring and low-coast modulator valve.

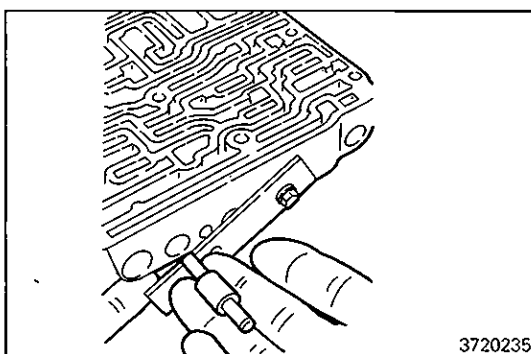

- (8) Slide the cover further to remove the plug.

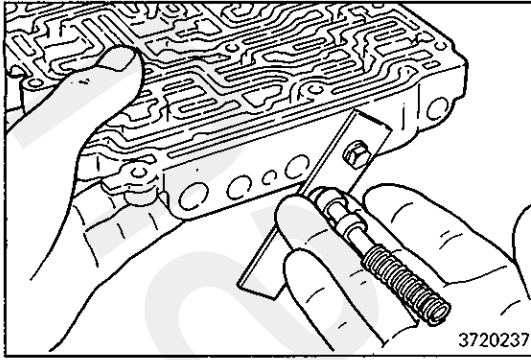

- (9) Rotate the cover still further to remove the spring and reverse clutch sequence valve.

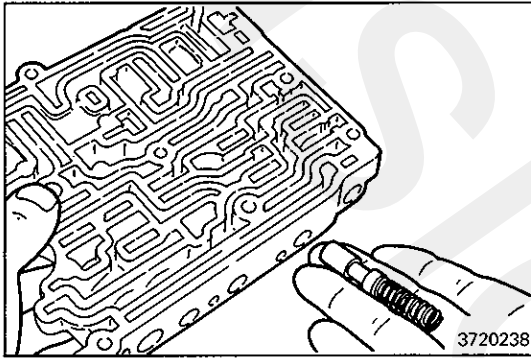

- (10) Remove the rear cover, spring and intermediate modulator valve.

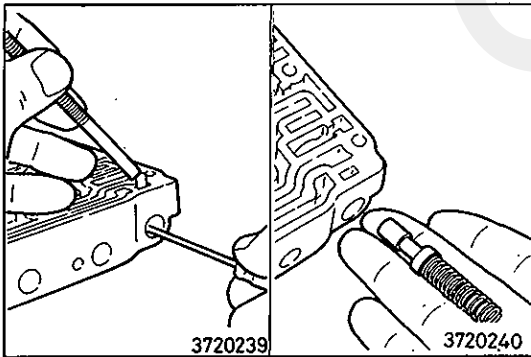

- (11) Remove the valve retainer from the detent regulator valve.  
 (12) Remove the spring and detent regulator valve.

## INSPECTION

- (1) Check the valve spring for damage, rust and permanent set. Measure the free length of the spring. If it is below the standard value, replace the spring. (Refer to Spring Identification Table.)

## REASSEMBLY

- (1) Install the detent regulator valve, spring and retainer as follows:  
 Insert the valve (with its rounded end down) and spring in the hole. Fit a large screwdriver on the spring end. Then compress the spring to install the retainer in the specified location.

### NOTE

Make sure that the retainer is installed over the entire end of the spring.

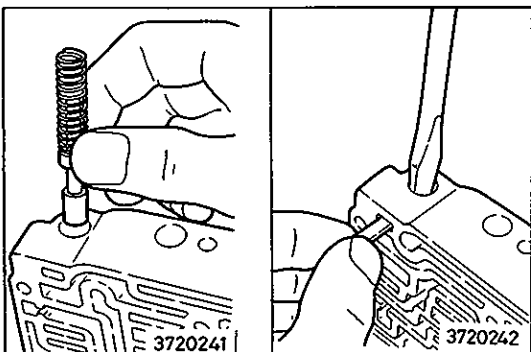

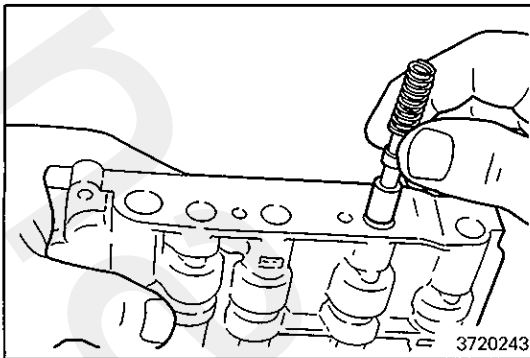

- (2) Insert the intermediate modulator valve and spring. Be sure to insert the valve with its rounded end down.

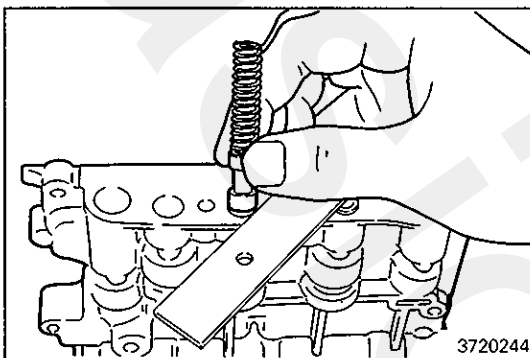

- (3) Put the rear valve cover in place and loosely tighten the bolt on the intermediate modulator valve side.  
 (4) Insert the reverse clutch sequence valve and spring. Be sure to insert the valve with its rounded end down.

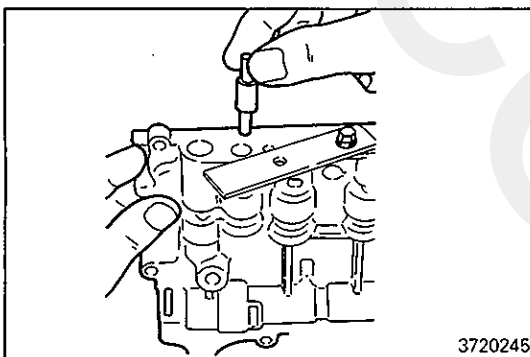

- (5) Insert the plug.

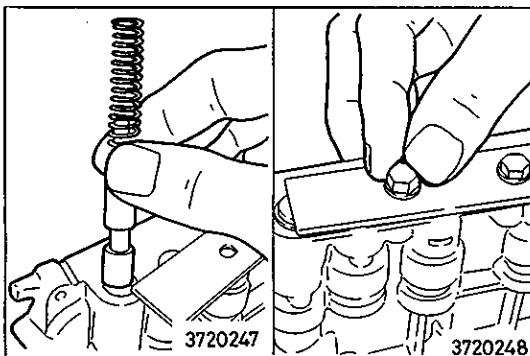

- (6) Insert the low-coast modulator valve and spring. Be sure to insert the valve with its rounded end down.

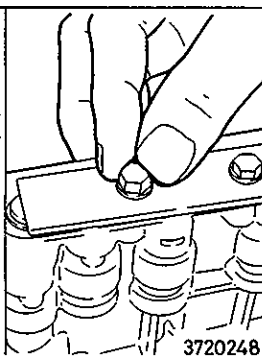

- (7) Install the other rear valve cover bolt and tighten both bolts.

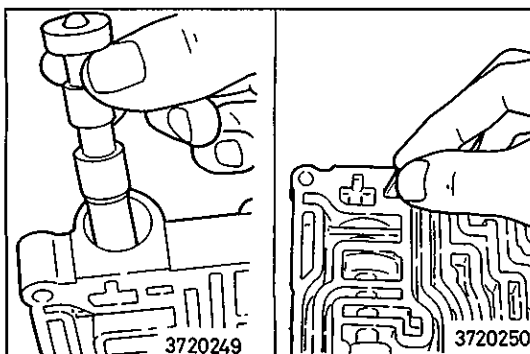

- (8) Insert the 2-3 shift valve as follows:  
 (a) Insert the 2-3 shift valve with its small end down. Then, insert the plug.

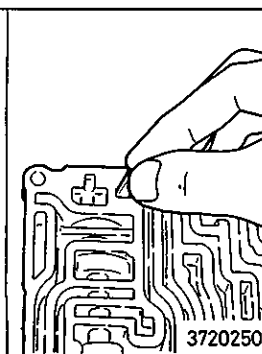

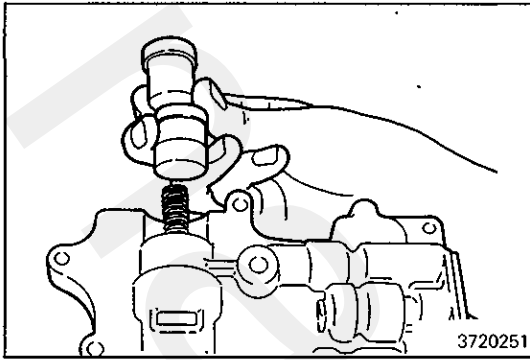

- (9) Insert the spring and intermediate-coast shift valve in the hole. Be sure to install the valve with its rounded end down.  
(10) Insert the valve and retainer.

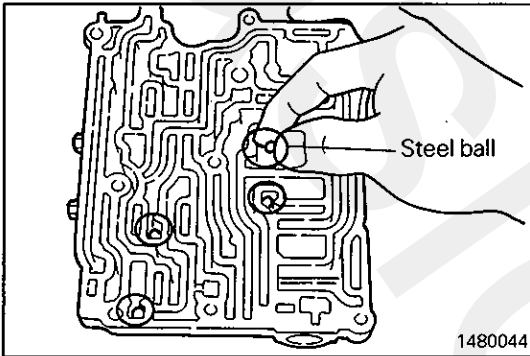

- (11) Install the steel ball in the location shown in the illustration. The three rubber balls are identical and may be installed in any location.

16. TRANSFER

V4AW2-1

DISASSEMBLY AND REASSEMBLY

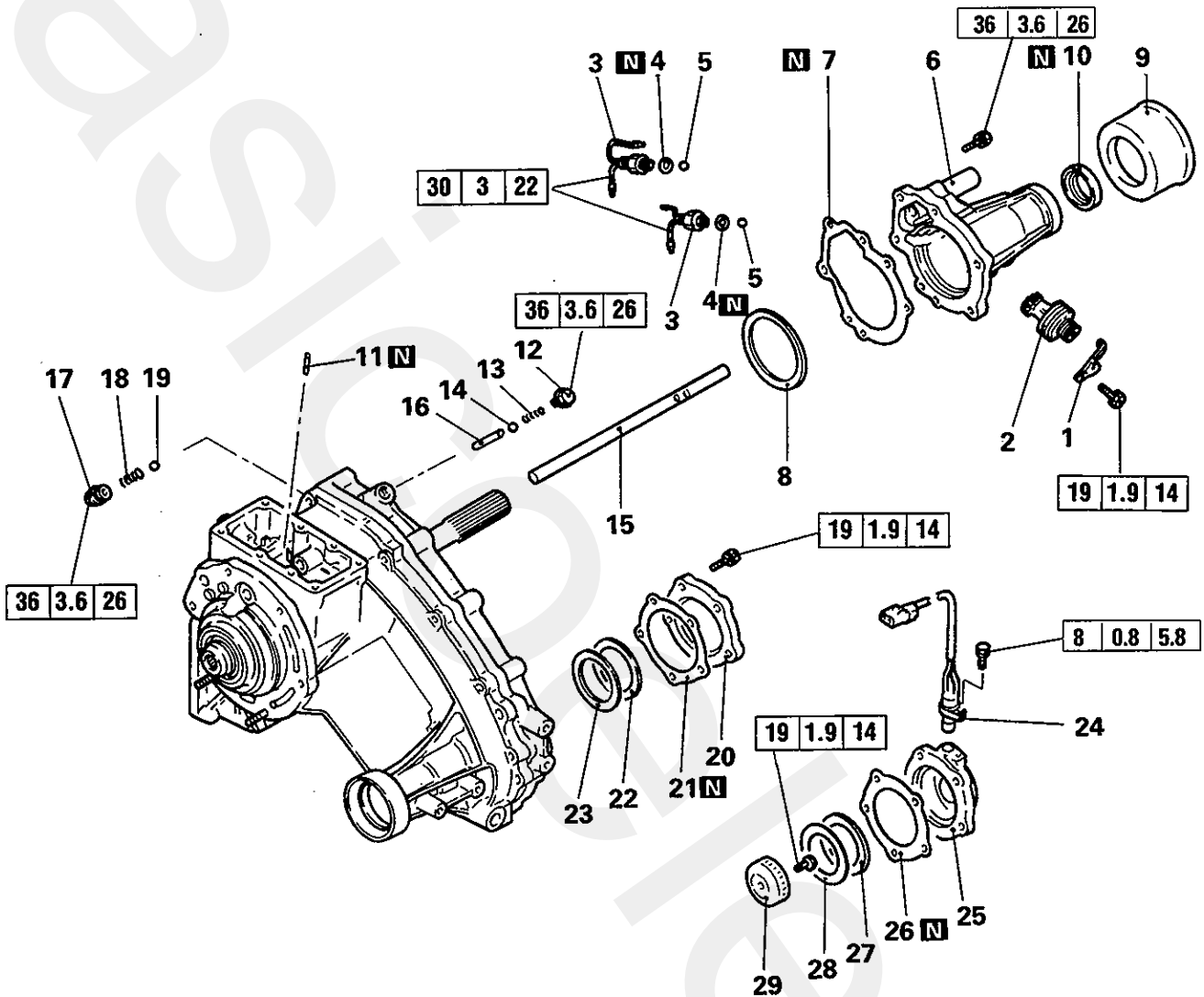

Disassembly steps

- 1. Sleeve clamp
- W 2. Speedometer gear
- 3. 4WD indicator light switch
- 4. Gasket
- 5. Steel ball
- V 6. Rear cover
- V 7. Rear cover gasket
- V 8. Spacer
- 9. Dust seal guard
- T 10. Oil seal
- O 11. Spring pin
- 12. Seal plug
- 13. Poppet spring
- 14. Steel ball
- A N 15. H-L shift rail

- 16. Interlock plunger
- 17. Seal plug
- 18. Poppet spring
- 19. Steel ball
- Q 20. Cover
- Q 21. Cover gasket
- 22. Spacer
- 23. Wave spring
- 24. Pulse generator
- Q 25. Cover
- Q 26. Cover gasket
- 27. Spacer
- 28. Wave spring
- 29. Pulse rotor

} Vehicles with pulse generator only

TRA0187

## V4AW2-1

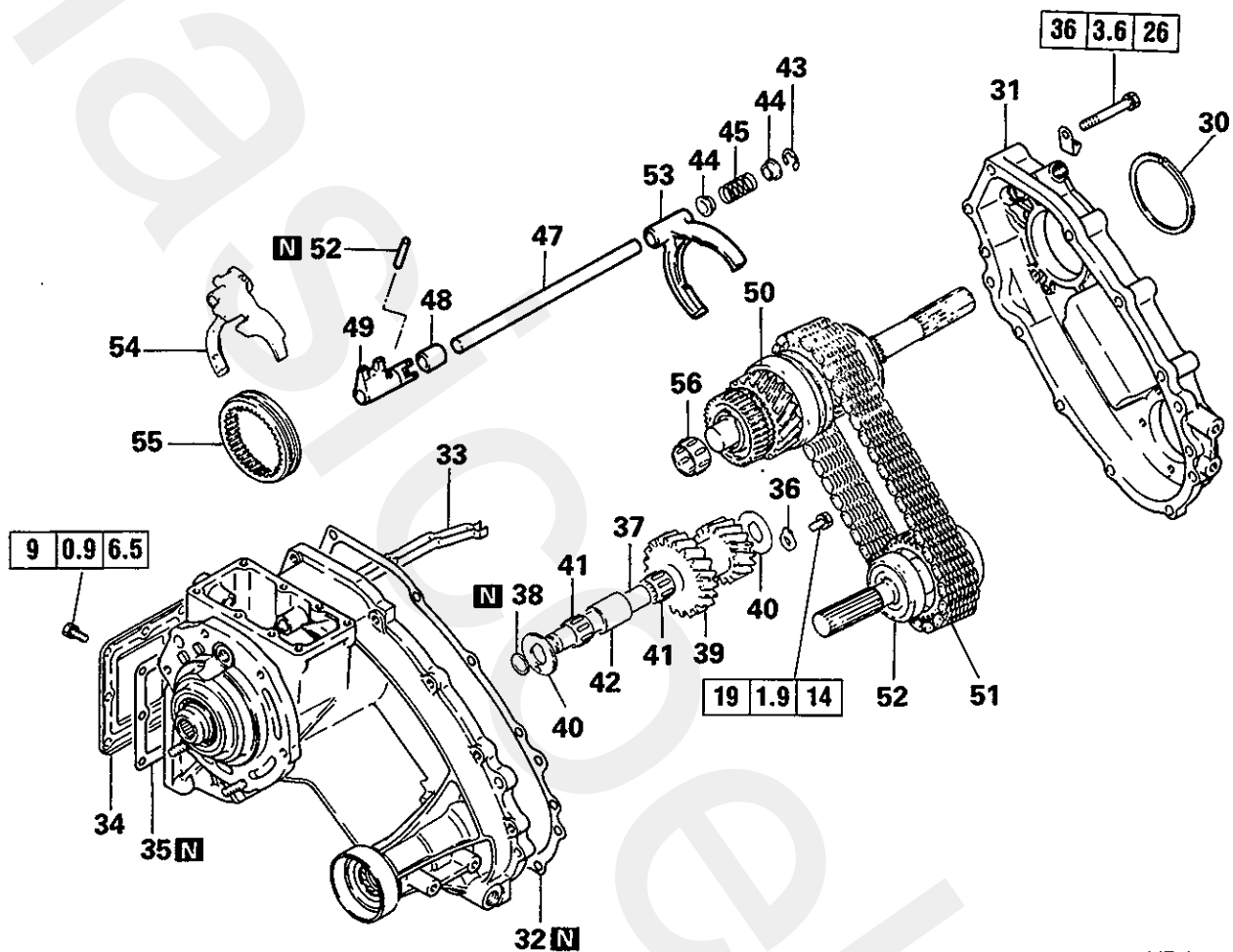

MT10021

## Disassembly steps

- 30. Snap ring
- ▶L▶ 31. Chain cover
- ▶K▶ 32. Chain cover gasket
- 33. Oil guide
- 34. Side cover
- 35. Side cover gasket
- 36. Lock plate
- 37. Counter gear shaft
- 38. O-ring
- 39. Counter gear
- ▶E▶ 40. Thrust washer
- 41. Needle bearing
- 42. Bearing spacer
- 43. Snap ring
- 44. Spring retainer
- 45. Spring
- ▶a▶ 46. Spring pin
- 47. 2-4WD shift rail
- 48. Distance piece
- 49. 2-4WD shift lug
- ◊C◊ ▶J▶ 50. Rear output shaft
- ◊C◊ ▶J▶ 51. Chain
- ◊C◊ ▶J▶ 52. Front output shaft
- 53. 2-4WD shift fork
- 54. H-L shift fork
- 55. H-L clutch sleeve
- 56. Needle bearing



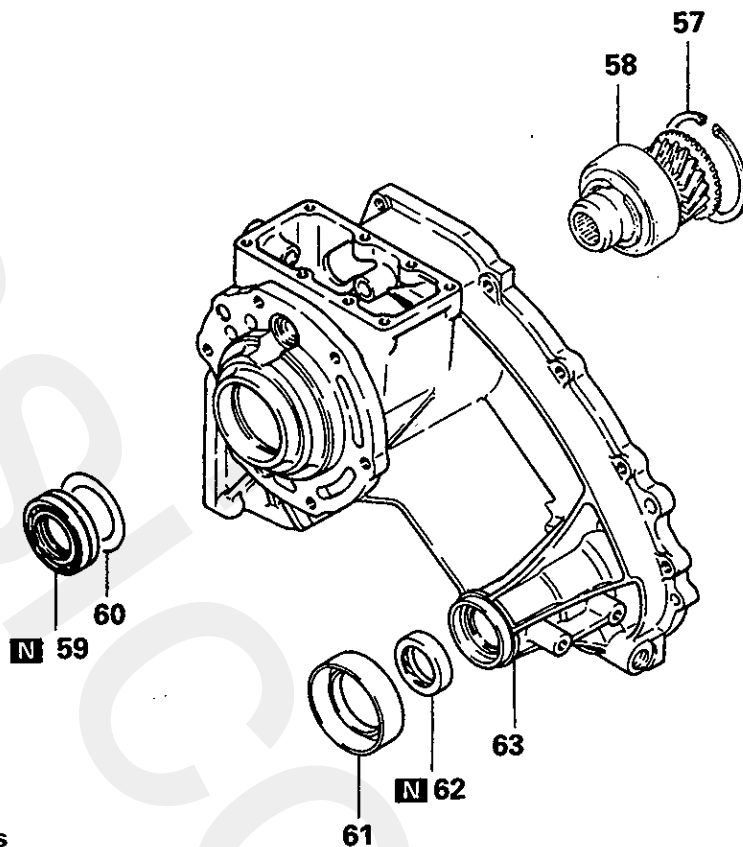

**Disassembly steps**

- ▶D 57. Snap ring
- 58. Input gear
- ▶B 59. Oil seal (Input gear)
- 60. Baffle plate
- 61. Dust seal guide
- ▶A 62. Oil seal (Front output shaft)
- 63. Transfer case

145084

**V4AW2-3, 7 (SUPER SELECT 4WD) • LHD**

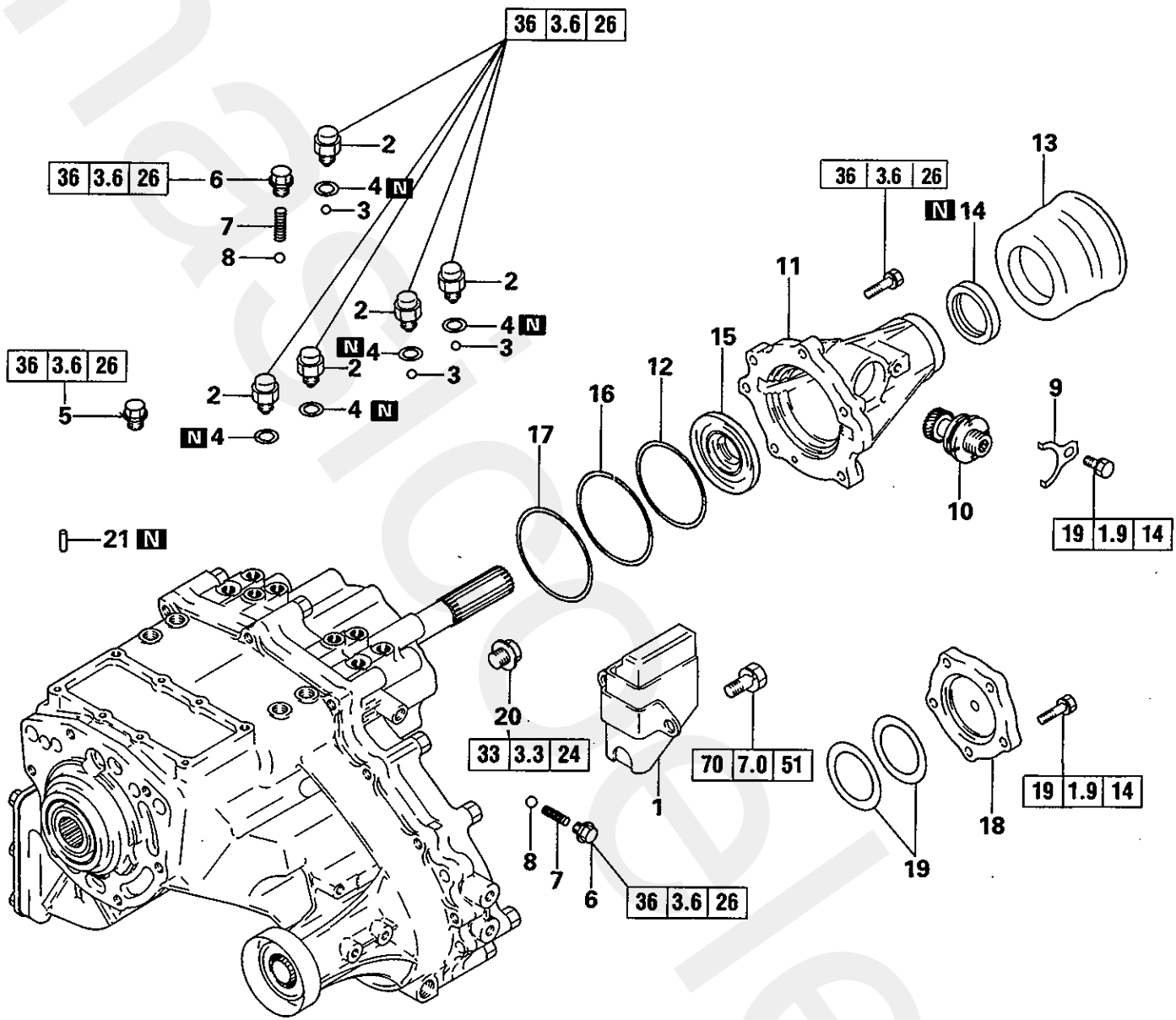

**Disassembly steps**

- 1. Dynamic damper (6G72 engine only)
- ◆Z◆ 2. Detection switch
- 3. Steel ball
- 4. Gasket
- ◆Y◆ 5. Plug
- ◆X◆ 6. Poppet plug
- 7. Poppet spring
- 8. Steel ball
- 9. Sleeve damp
- ◆W◆ 10. Speedometer gear
- ◆U◆ 11. Rear cover

- ◆U◆ 12. Spacer
- 13. Dust seal guard
- ◆T◆ 14. Oil seal
- ◆S◆ 15. Oil seal
- ◆R◆ 16. Snap ring } (Up to November 1992)
- ◆R◆ 17. Spacer
- ◆P◆ 18. Cover
- ◆P◆ 19. Wave spring (Spacer)
- 20. H-L shift rail plug
- ◆O◆ 21. Spring pin (H-L shift fork)

TRM0259

V4AW2-3, 7 (SUPER SELECT 4WD) • LHD

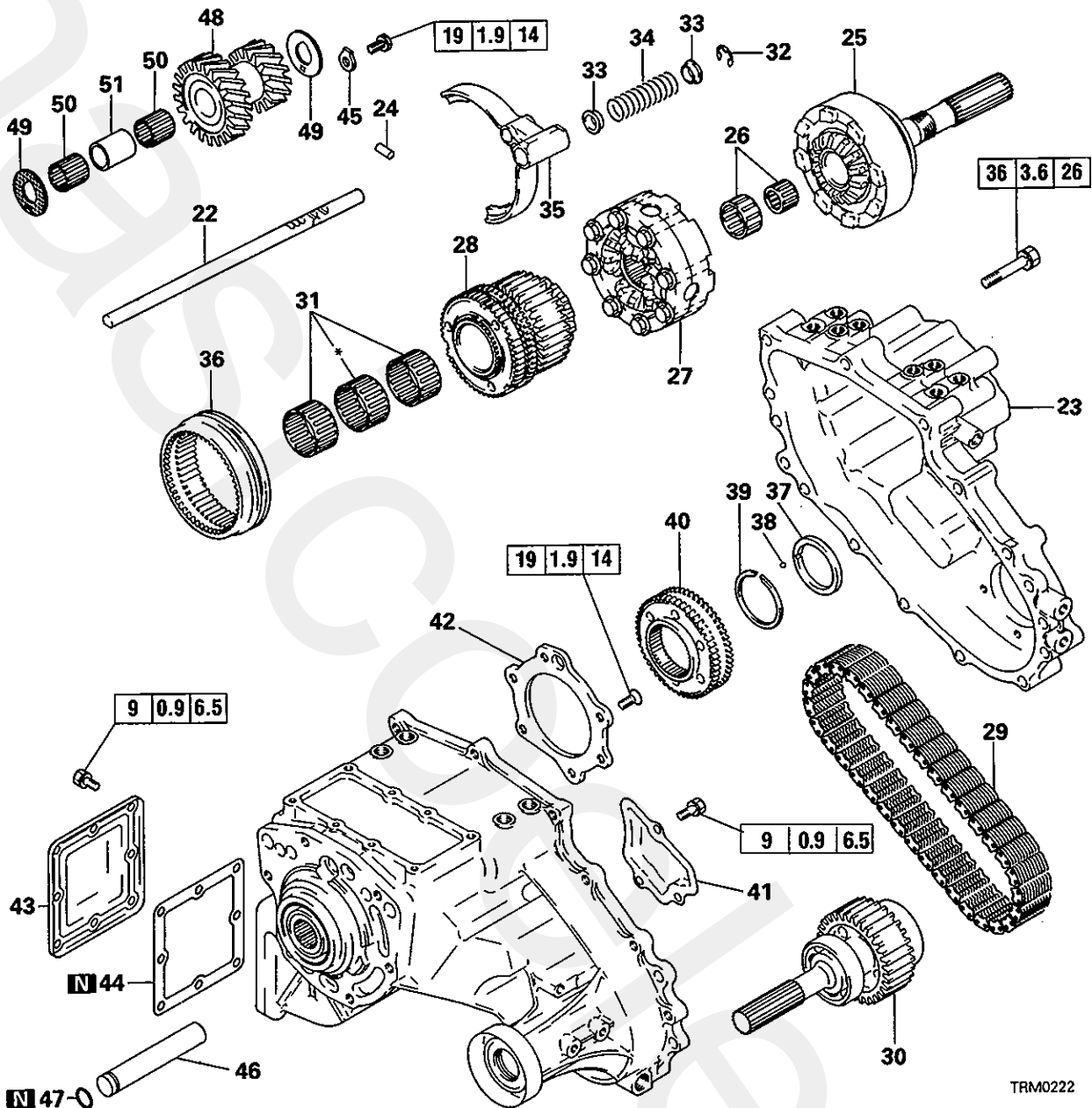

**Disassembly steps**

- ◇B◇ ▶O◇ 22.H-L shift rail
- ◇B◇ ▶M◇ 23.Chain cover
- ▶M◇ 24.Interlock plunger
- 25.Rear output shaft
- 26.Needle bearing
- 27.Center differential case
- ◇D◇ ▶I◇ 28.2-4WD synchronizer
- ◇D◇ ▶I◇ 29.Chain
- ◇D◇ ▶I◇ 30.Front output shaft
- 31.Needle bearing
- 32.Snap ring (2-4WD shift rail)
- 33.Spring seat
- 34.Spring
- 35.2-4WD shift fork
- 36.2-4WD synchronizer sleeve

- 37.Sleeve
- 38.Steel ball
- ▶H◇ 39.Snap ring
- 40.Differential lock hub
- 41.Oil dam cover
- ▶G◇ 42.Bearing retainer
- 43.Side cover
- 44.Side cover gasket
- 45.Lock plate
- ◇Et◇ ▶F◇ 46.Counter gear shaft
- 47.O-ring
- 48.Counter gear
- ▶E◇ 49.Thrust washer
- 50.Needle bearing
- 51.Bearing spacer

**NOTE**

\* One needle bearing disused (From December 1992)

TRM0222

## V4AW2-3, 7 (SUPER SELECT 4WD) • LHD

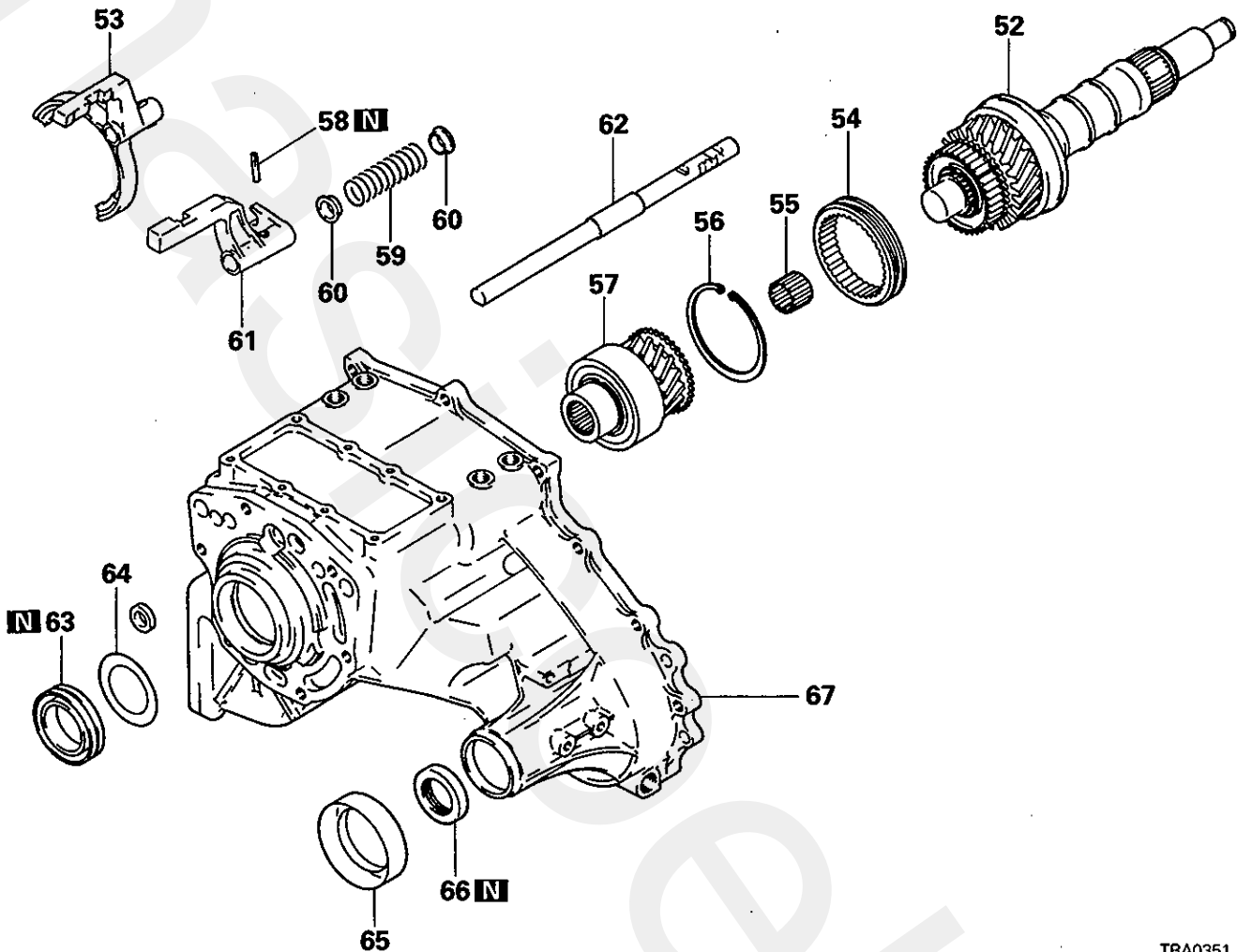

TRA0351

**Disassembly steps**

- 52. Drive shaft
- 53. H-L shift fork
- 54. H-L clutch sleeve
- 55. Needle bearing
- ▶D▶ 56. Snap ring
- 57. Input gear
- ▶C▶ 58. Spring pin (2-4WD shift lug)
- ▶C▶ 59. Spring
- ▶C▶ 60. Spring retainer
- ▶C▶ 61. 2-4WD shift lug
- ▶C▶ 62. 2-4WD shift rail
- ▶B▶ 63. Oil seal (Input gear)
- 64. Baffle plate
- 65. Dust seal guard
- ▶A▶ 66. Oil seal (Front output shaft)
- 67. Transfer case

V4AW2-3, 7 (SUPER SELECT 4WD) • RHD

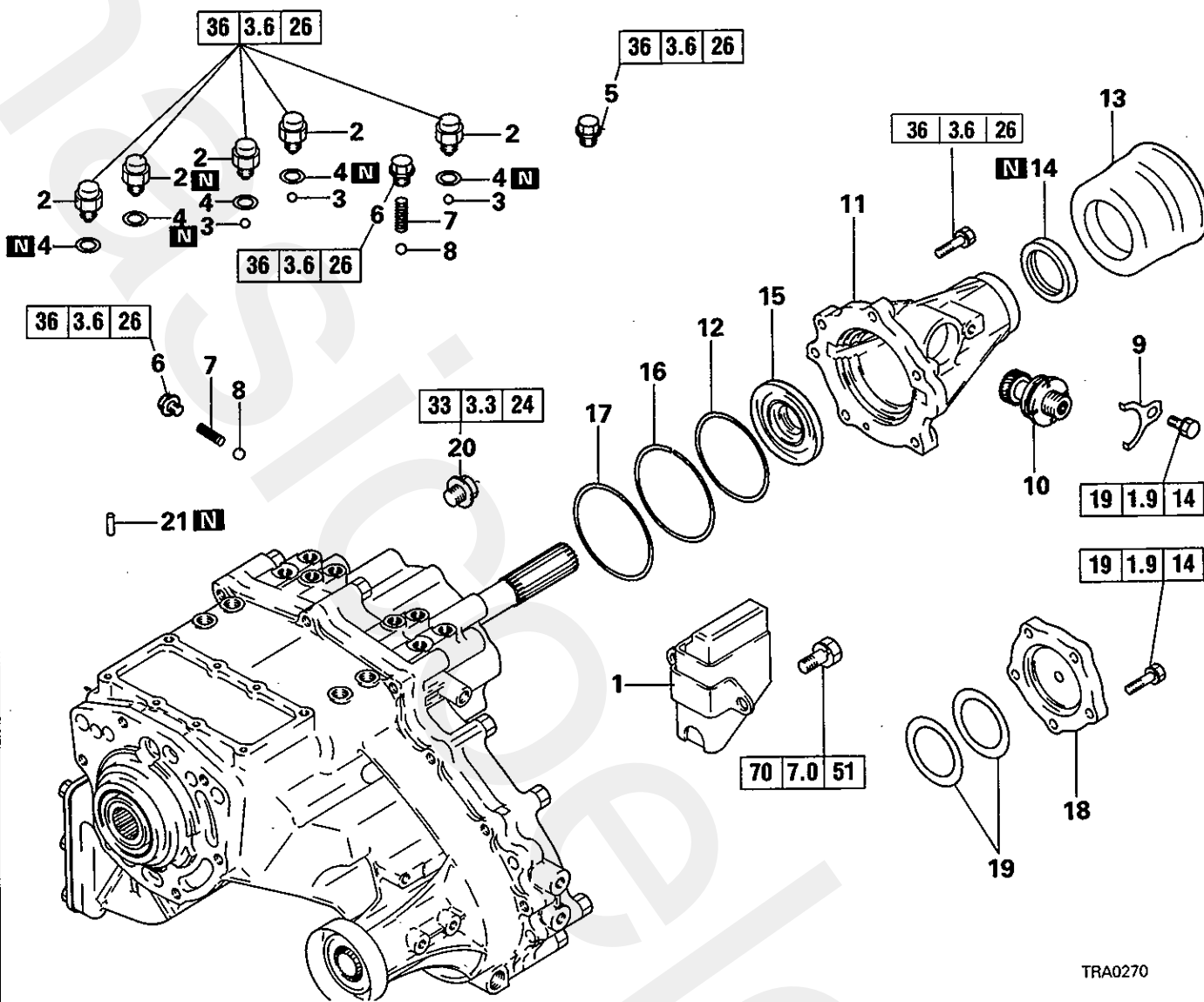

TRA0270

**Disassembly steps**

- 1. Dynamic damper (6G72 engine only)
- Z 2. Detection switch
- 3. Steel ball
- 4. Gasket
- Y 5. Plug
- X 6. Poppet plug
- 7. Poppet spring
- 8. Steel ball
- 9. Sleeve damp
- W 10. Speedometer gear
- U 11. Rear cover
- U 12. Spacer
- 13. Dust seal guard
- T 14. Oil seal
- S 15. Oil seal
- R 16. Snap ring } (Up to November 1992)
- R 17. Spacer }
- P 18. Cover
- P 19. Wave spring (Spacer)
- 20. H-L shift rail plug
- O 21. Spring pin (H-L shift fork)

## V4AW2-3, 7 (SUPER SELECT 4WD) • RHD

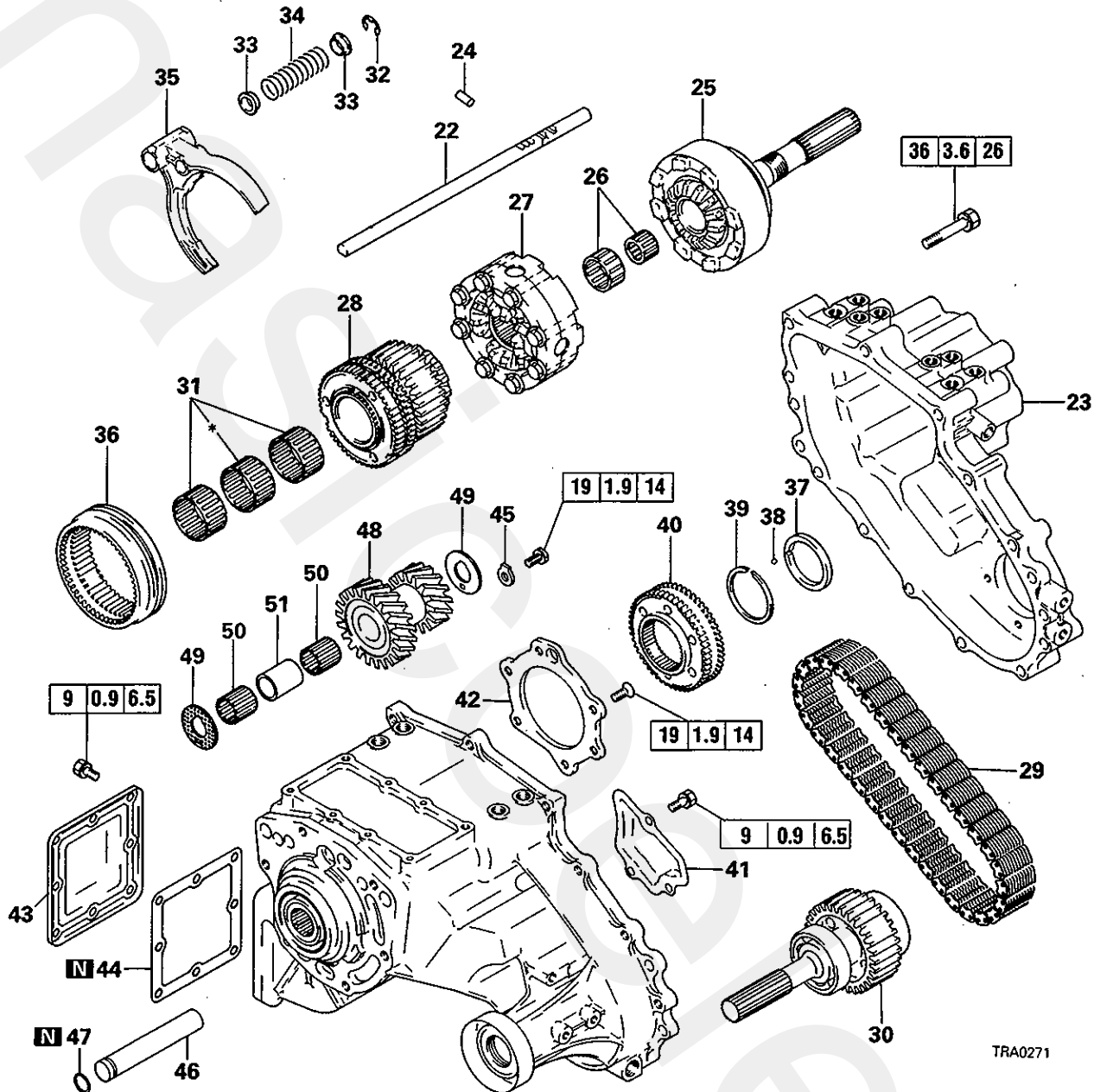

TRA0271

## NOTE

\*One needle bearing disused (From December 1992)

## Disassembly steps

- ◊B◊ ◯ 22. H-L shift rail
- ◊B◊ ◯M 23. Chain cover
- ◯M 24. Interlock plunger
- 25. Rear output shaft
- 26. Needle bearing
- 27. Center differential case
- ◊D◊ ◯I 28. 2-4WD synchronizer
- ◊D◊ ◯I 29. Chain
- ◊D◊ ◯I 30. Front output shaft
- ◊D◊ ◯I 31. Needle bearing
- 32. Snap ring (2-4WD shift rail)
- 33. Spring seat
- 34. Spring
- 35. 2-4WD shift fork
- 36. 2-4WD synchronizer sleeve

- 37. Sleeve
- 38. Steel ball
- ◯H 39. Snap ring
- 40. Differential lock hub
- 41. Oil dam cover
- ◯G 42. Bearing retainer
- 43. Side cover
- 44. Side cover gasket
- 45. Lock plate
- ◊E◊ ◯F 46. Counter gear shaft
- 47. O-ring
- 48. Counter gear
- ◯E 49. Thrust washer
- 50. Needle bearing
- 51. Bearing spacer

V4AW2-3, 7 (SUPER SELECT 4WD) • RHD

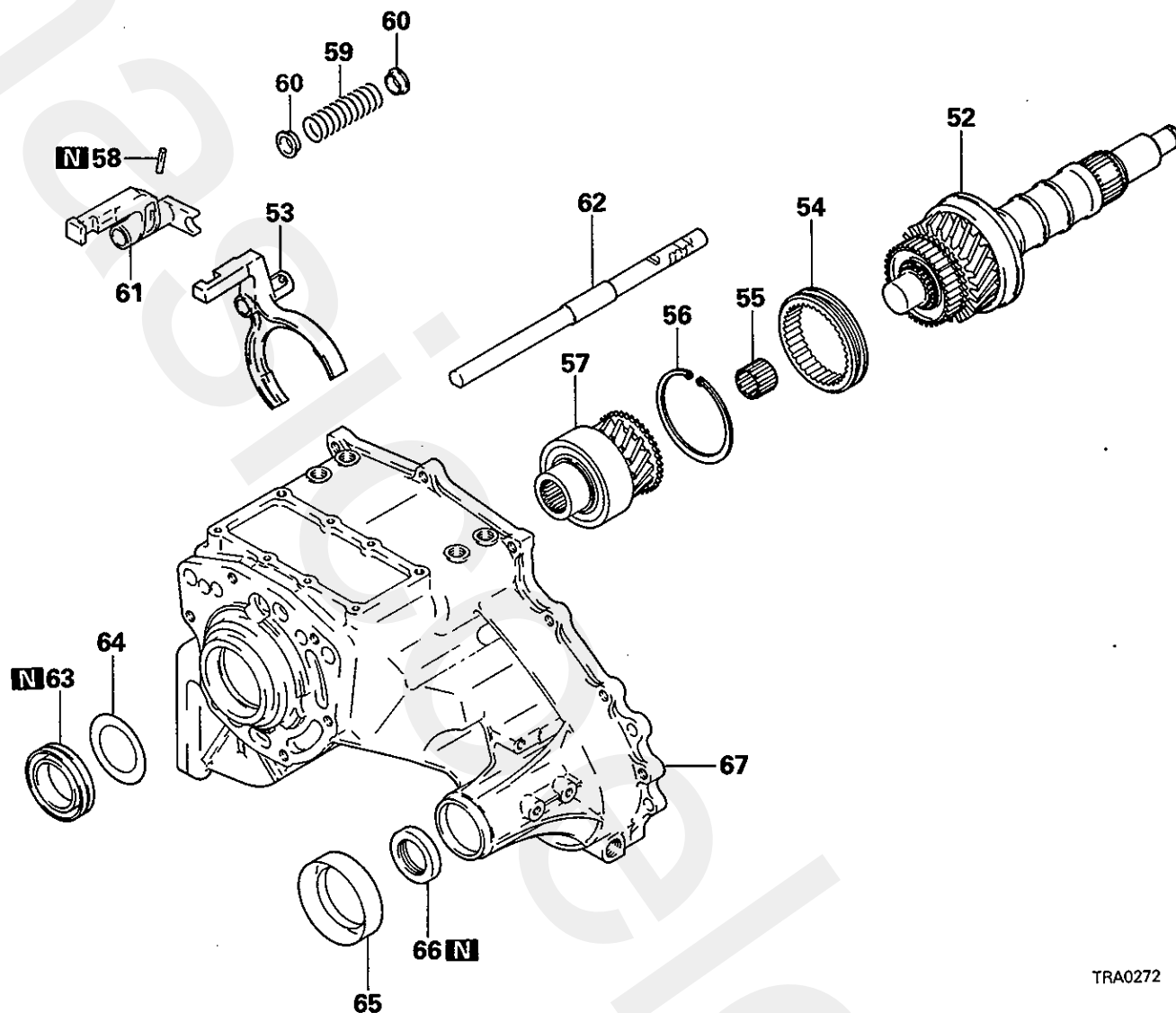

TRA0272

**Disassembly steps**

- 52. Drive shaft
- 53. H-L shift fork
- 54. H-L clutch sleeve
- 55. Needle bearing
- ▶D▶ 56. Snap ring
- 57. Input gear
- ▶C▶ 58. Spring pin (2-4WD shift lug)
- ▶C▶ 59. Spring
- ▶C▶ 60. Spring retainer
- ▶C▶ 61. 2-4WD shift lug
- ▶C▶ 62. 2-4WD shift rail
- ▶B▶ 63. Oil seal
- 64. Baffle plate
- 65. Dust seal guard
- ▶A▶ 66. Oil seal
- 67. Transfer case

## V4AW2-3, 7 (PART TIME 4WD)

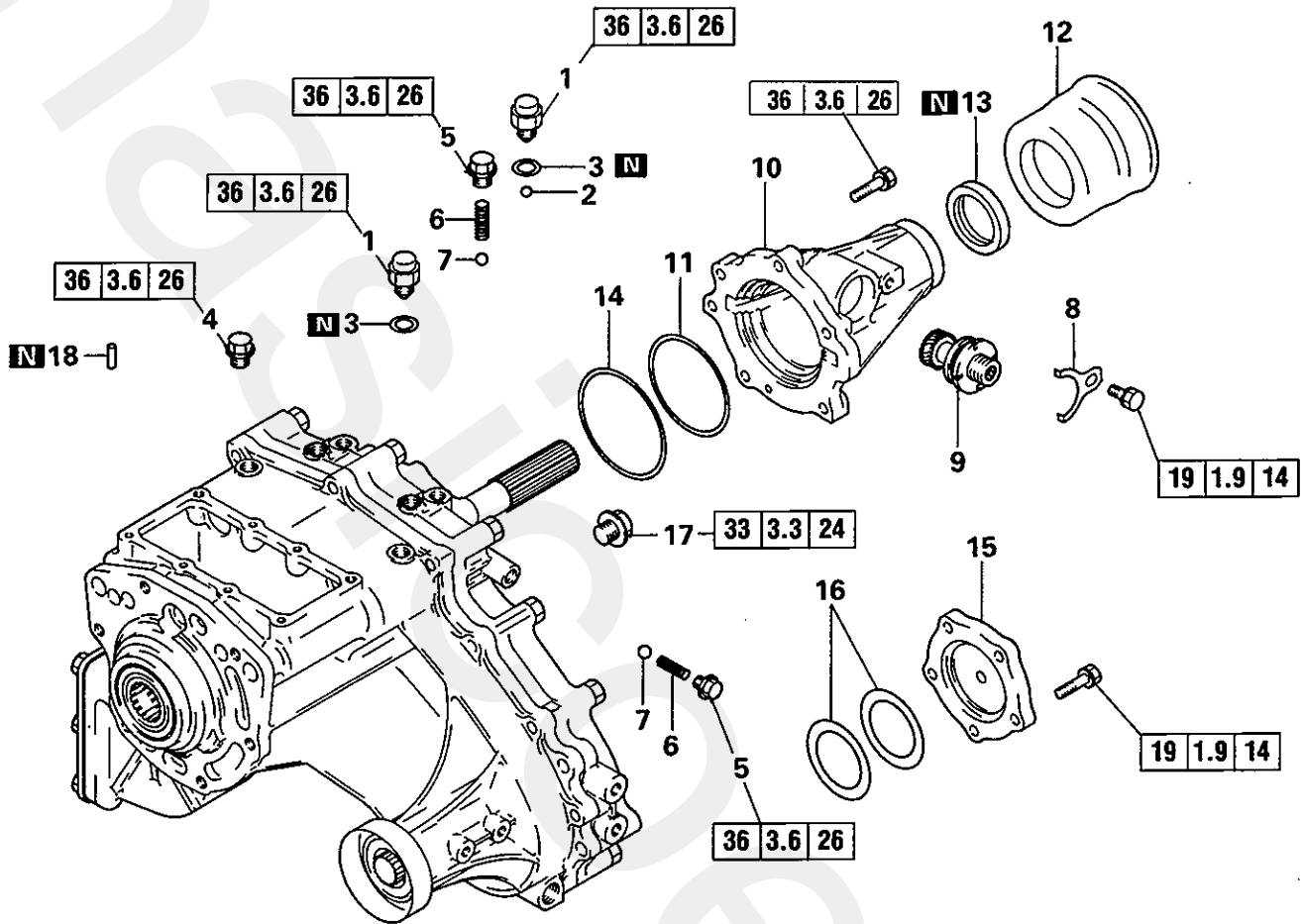

TRA0257

## Disassembly steps

- ◆Z◆ 1. Detection switch
- 2. Steel ball
- 3. Gasket
- ◆Y◆ 4. Plug
- ◆X◆ 5. Poppet plug
- 6. Poppet spring
- 7. Steel ball
- 8. Sleeve clamp
- ◆W◆ 9. Speedometer gear
- ◆U◆ 10. Rear cover
- ◆U◆ 11. Spacer
- 12. Dust seal guard
- ◆T◆ 13. Oil seal
- 14. Snap ring
- ◆P◆ 15. Cover
- ◆P◆ 16. Wave spring (Spacer)
- 17. H-L shift rail plug
- ◆O◆ 18. Spring pin (H-L shift fork)



V4AW2-3, 7 (PART TIME 4WD)

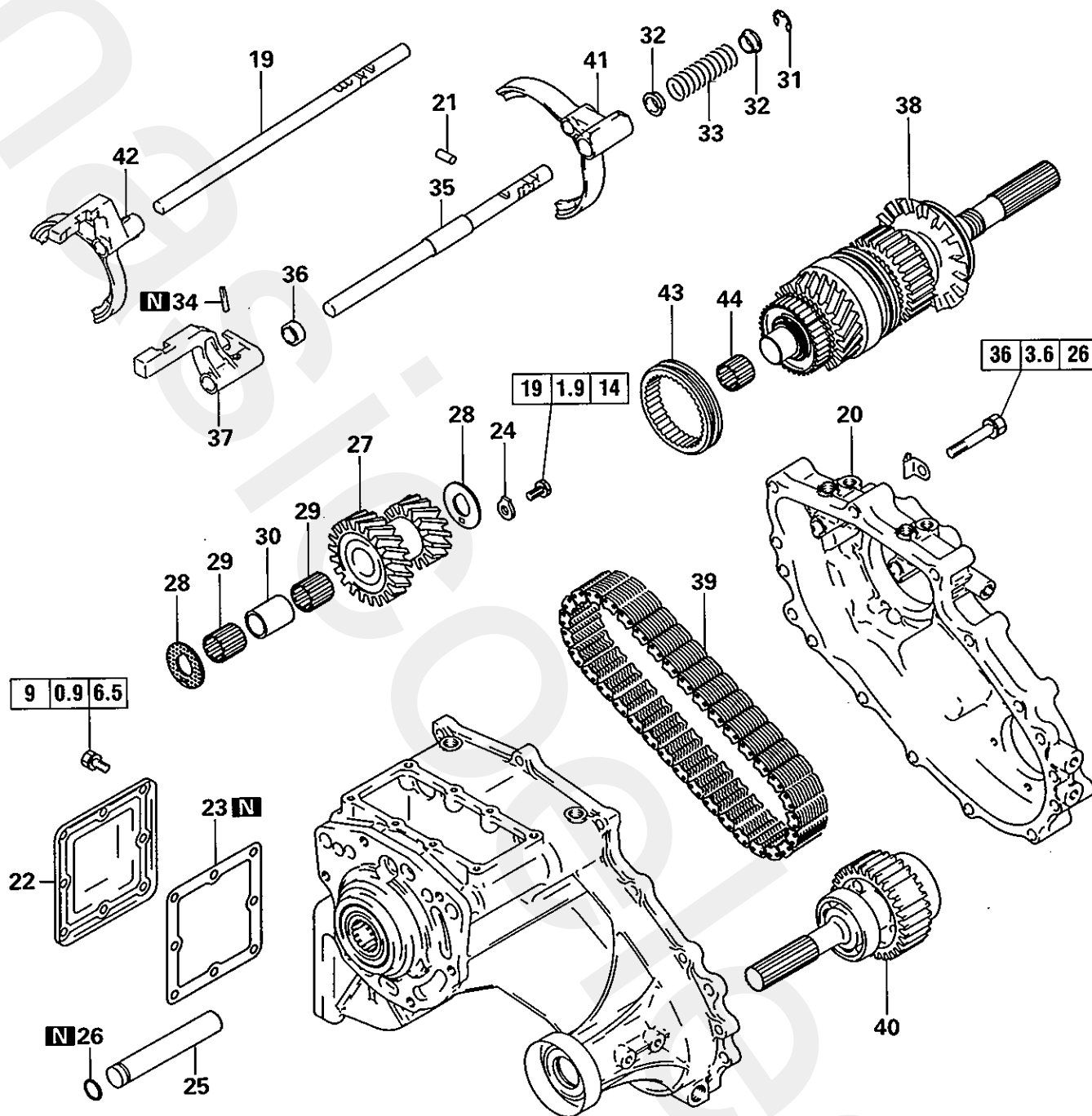

**Disassembly steps**

- ◊B◊ ◊O◊ 19. H-L shift rail
- ◊B◊ ◊M◊ 20. Chain cover
- ◊M◊ 21. Interlock plunger
- 22. Side cover
- 23. Side cover gasket
- 24. Lock plate
- ◊E◊ ◊F◊ 25. Counter gear shaft
- 26. O-ring
- ◊E◊ 27. Counter gear
- ◊E◊ 28. Thrust washer
- 29. Needle bearing
- 30. Bearing spacer
- 31. Snap ring (2-4WD shift rail)

- 32. Spring retainer
- 33. Spring
- ◊a◊ 34. Spring pin (2-4WD shift lug)
- 35. 2-4WD shift rail
- 36. Distance piece
- 37. 2-4WD shift lug
- ◊C◊ ◊J◊ 38. Rear output shaft
- ◊C◊ ◊J◊ 39. Chain
- ◊C◊ ◊J◊ 40. Front output shaft
- 41. 2-4WD shift fork
- 42. H-L shift fork
- 43. H-L clutch sleeve
- 44. Needle bearing

TRA0353

## V4AW2-3, 7 (PART TIME 4WD)

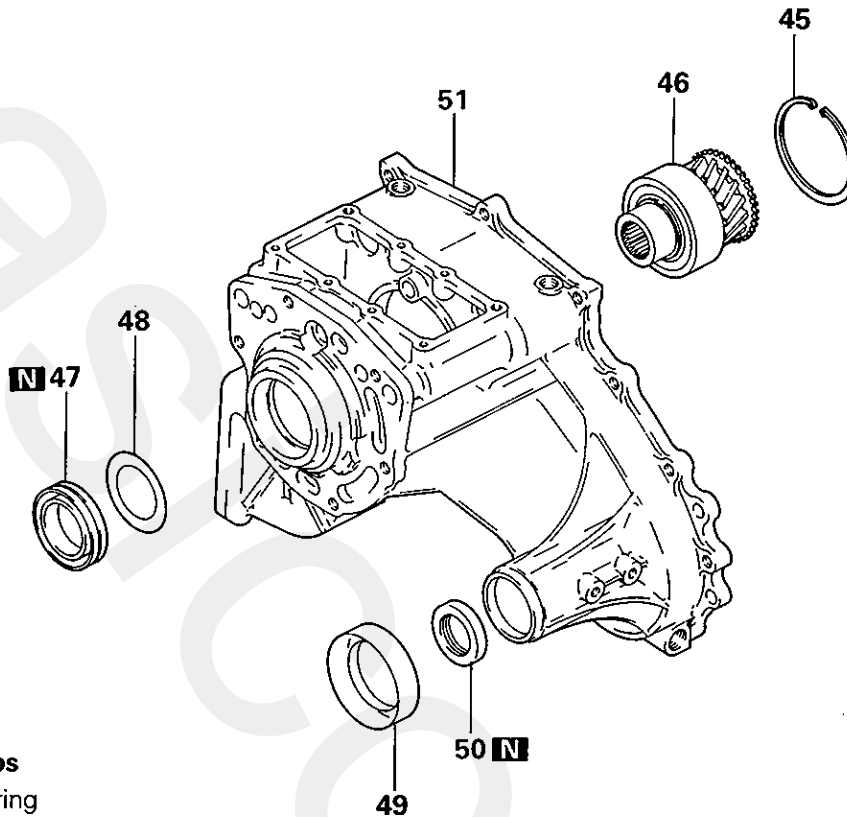

## Disassembly steps

- ◆D◆ 45. Snap ring
- ◆B◆ 46. Input gear
- ◆B◆ 47. Oil seal (Input gear)
- 48. Baffle plate
- 49. Dust seal guide
- ◆A◆ 50. Oil seal (Front output shaft)
- 51. Transfer case

TRA0275

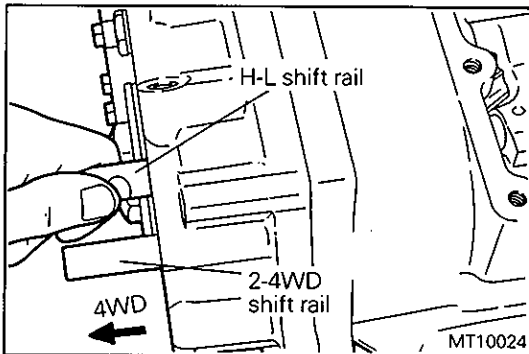

## SERVICE POINTS OF DISASSEMBLY

## ◁A▷ REMOVAL OF H-L SHIFT RAIL

- (1) Shift the 2-4WD shift rail to the 4WD position.

## NOTE

If the 2-4WD shift rail is left in the 2WD position, the interlock is actuated, preventing removal of the H-L shift rail.

- (2) Remove the H-L shift rail.

## ◁B▷ REMOVAL OF H-L SHIFT RAIL, CHAIN COVER

- (1) Fix the H-L shift rail at the High side, using the poppet spring.
- (2) Place the 2-4WD shift rail at the 4WD position.

## NOTE

If the 2-4WD shift rail is placed at the 2WD position, the chain cover cannot be removed because of interlocking.

- (3) Remove the chain cover and remove the H-L shift rail.

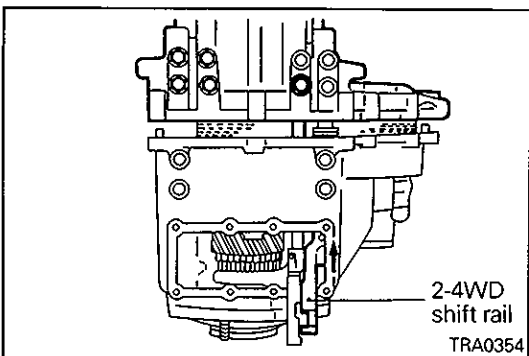

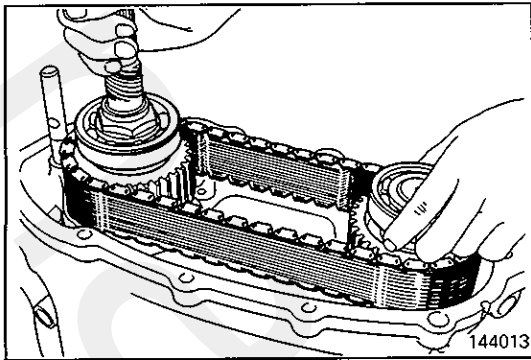

**◁C▷ REMOVAL OF REAR OUTPUT SHAFT, CHAIN, FRONT OUTPUT SHAFT**

- (1) Remove the front output shaft, rear output shaft and chain together.

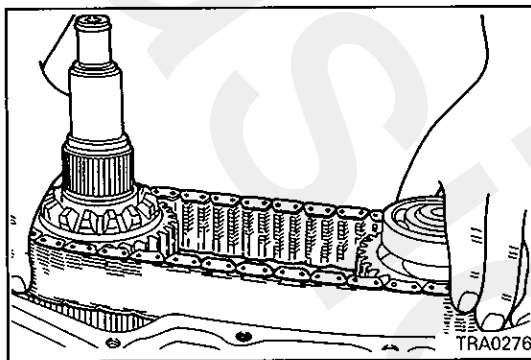

**◁D▷ REMOVAL OF 2-4WD SYNCHRONIZER, CHAIN FRONT OUTPUT SHAFT**

- (1) Remove the 2-4WD Synchronizer, front output shaft and chain together.

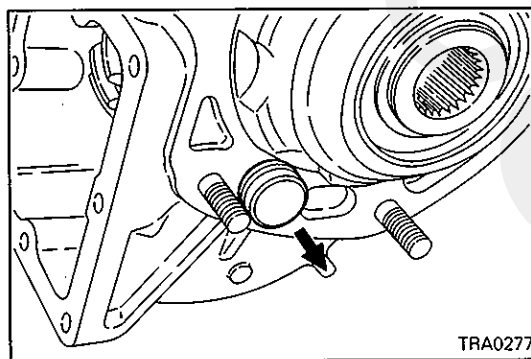

**◁E▷ REMOVAL OF COUNTER GEAR SHAFT**

- (1) Remove the counter gear shaft toward the transmission case.

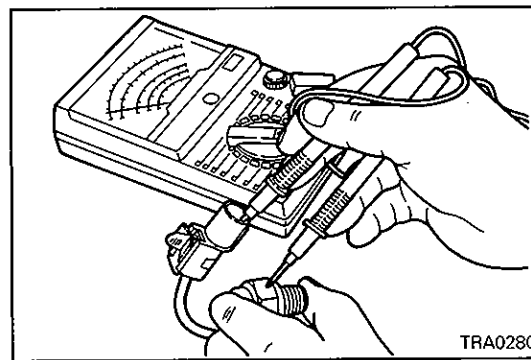

**INSPECTION**

**INSPECTION OF DETECTION SWITCH**

- (1) Check for continuity across the connector terminal and switch body.

Switch state	Continuity
Switch end pressed	No
Switch end released	Yes

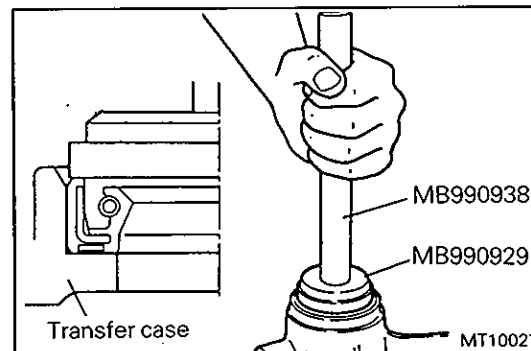

**SERVICE POINTS OF REASSEMBLY**

**▶A▶ INSTALLATION OF OIL SEAL (FRONT OUTPUT SHAFT)**

- (1) Apply transmission oil to the lip of the oil seal before press-fitting.

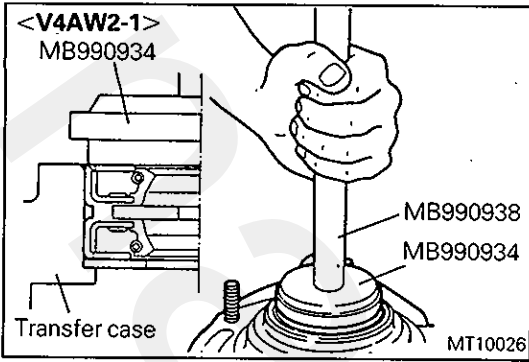

**▶B▶ INSTALLATION OF OIL SEAL (INPUT GEAR)**

- (1) Apply transmission oil to the lip of the oil seal before press-fitting.

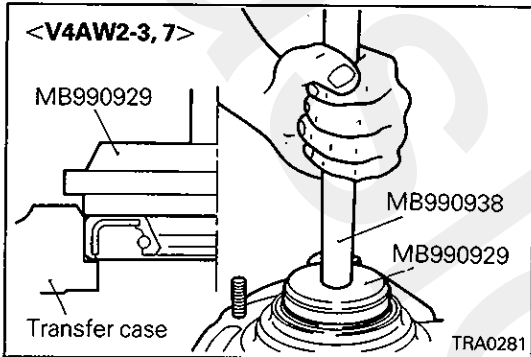

**▶C▶ INSTALLATION OF 2-4WD SHIFT RAIL, 2-4WD SHIFT LUG, SPRING RETAINER, SPRING, SPRING PIN FOR 2-4WD SHIFT LUG**

- (1) Mount the spring retainer and spring in the shift rail and set with the shift lug in the transfer case.
- (2) While paying attention to the direction of the shift rail, line up the shift lug and shift rail spring pin hole.
- (3) While pressing the rail, install the spring pin in such a way that the slit of the spring pin will face the axial center of the shift rail.

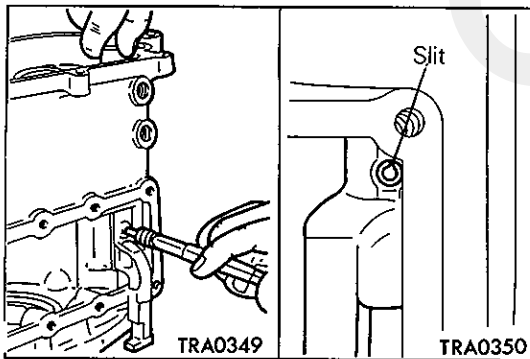

**▶D▶ INSTALLATION OF SNAP RING**

- (1) Select the thickest snap ring that will fit into the groove and install it.

**Standard value: 0 – 0.06 mm (0 – 0.0024 in.)**

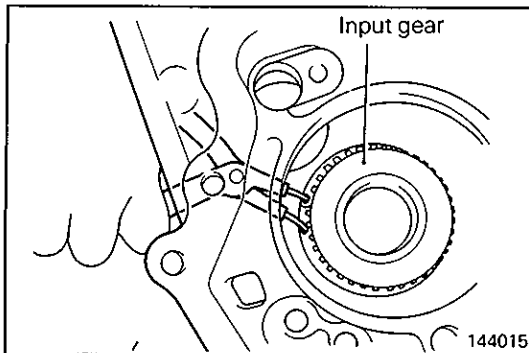

**▶E▶ INSTALLATION OF THRUST WASHER**

- (1) Install the thrust washer so that the tab will fit in the groove of the case.

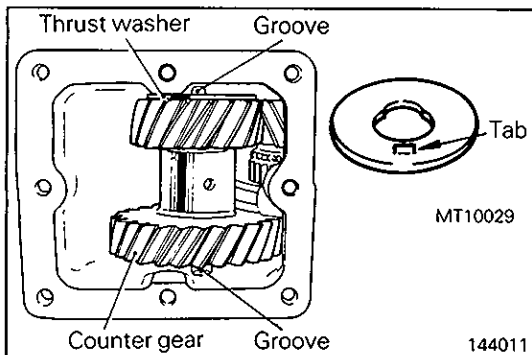

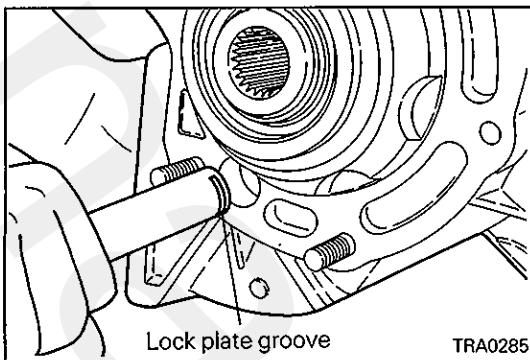

**◆F◆ INSTALLATION OF COUNTER GEAR SHAFT**

- (1) Insert the transfer counter gear shaft from the transmission case side, while paying attention to the lock plate groove position.

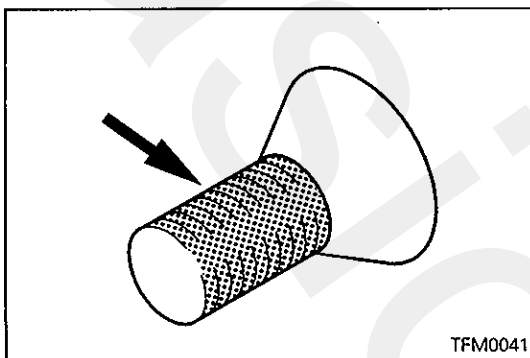

**◆G◆ INSTALLATION OF BEARING RETAINER**

- (1) The bearing retainer screw is a precoated bolt. When it is to be reused, apply a sealant beforehand.

**Specified adhesive:**

**3M STUD Locking No. 4170 or equivalent**

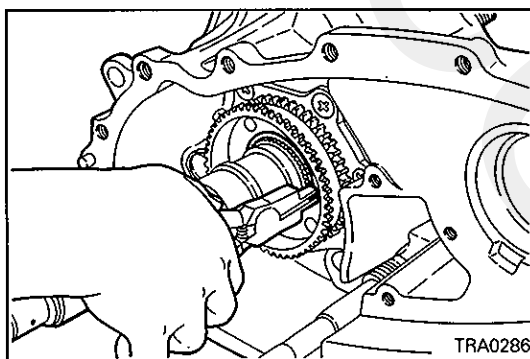

**◆H◆ INSTALLATION OF SNAP RING**

- (1) Select and install the thickest snap ring that can fit in the groove.

**Standard value: 0 – 0.08 mm (0 – 0.003 in.)**

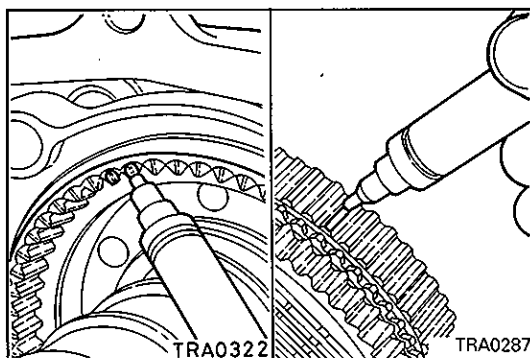

**◆I◆ INSTALLATION OF 2-4WD SYNCHRONIZER, CHAIN, FRONT OUTPUT SHAFT**

- (1) Make a white paint mark on the deep groove portions (three places) of the 2-4WD synchronizer.
- (2) Make a white paint mark on the projections (three places) of the 2-4WD synchronizer sleeve splines.

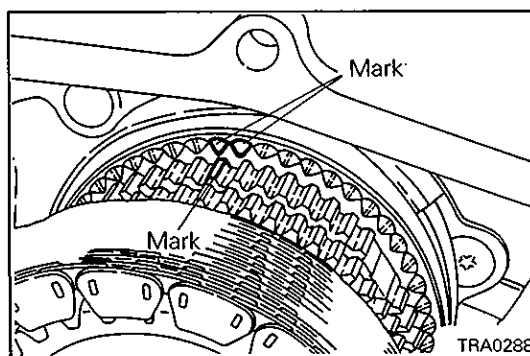

- (3) Place the chain in tight mesh with the 2-4WD synchronizer and front output shaft sprockets.
- (4) With both sprockets spaced the farthest apart, install them on the transfer case simultaneously.

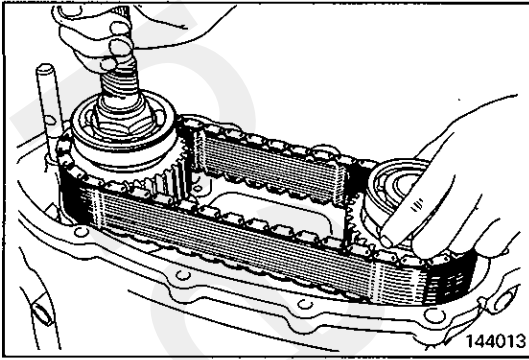

### ◆J◆ INSTALLATION OF REAR OUTPUT SHAFT, CHAIN, FRONT OUTPUT SHAFT

- (1) Engage the chain precisely with the sprockets of the rear output shaft and the front output shaft.
- (2) Install the 2-4WD shift fork on the 2-4WD clutch sleeve. While passing them along the 2-4WD shift rail, install the rear and front output shaft and chain.

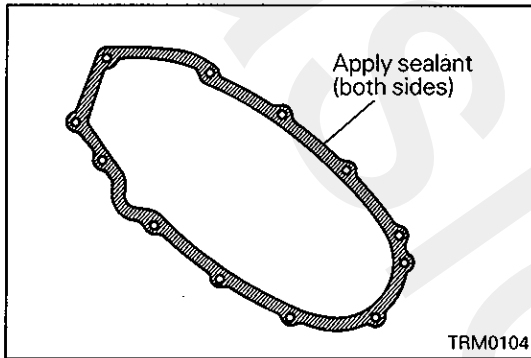

### ◆K◆ APPLICATION OF SEALANT TO CHAIN COVER GASKET

#### Specified sealant:

**Mitsubishi genuine sealant Part No. 997740 or equivalent**

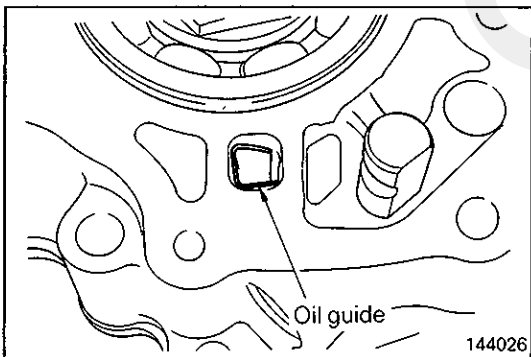

### ◆L◆ INSTALLATION OF CHAIN COVER

- (1) Install the chain cover so that the end of the oil guide may enter the hole shown in the illustration.

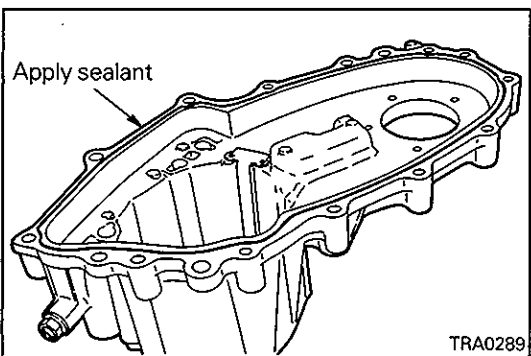

### ◆M◆ INSTALLATION OF CHAIN COVER, INTERLOCK PLUNGER

- (1) Insert the interlock plunger into a position where it does not interfere with the 2-4WD shift rail.
- (2) Apply a sealant to the chain cover before installing it.

#### Specified sealant:

**Mitsubishi genuine sealant Part No. 997740 or equivalent**

#### Caution

- Squeeze the sealant out evenly to make sure that it is not broken or excessively supplied.

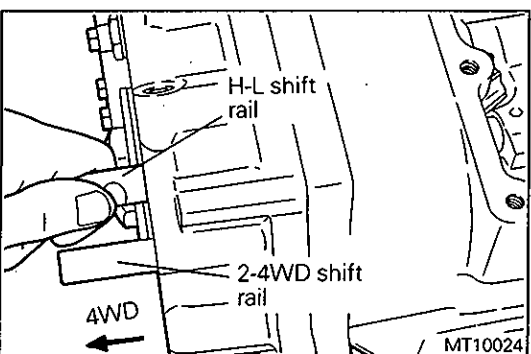

### ◆N◆ INSTALLATION OF H-L SHIFT RAIL

- (1) Shift the 2-4WD shift rail to the 4WD position.
- (2) Insert the H-L shift rail from the case and pass the rail through the shift fork.

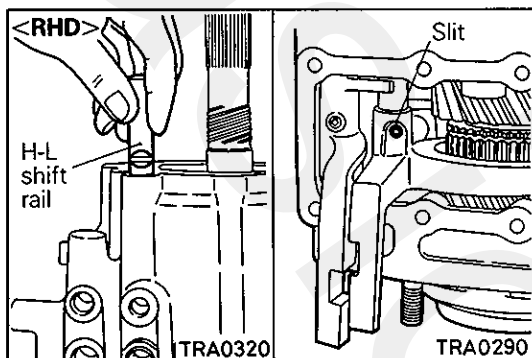
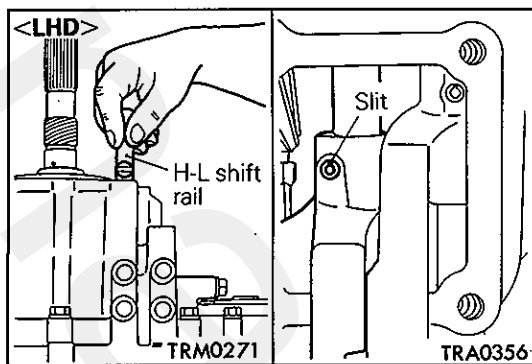

**0** INSTALLATION OF H-L SHIFT RAIL, SPRING PIN FOR H-L SHIFT FORK

- (1) Insert the H-L shift rail from the H-L shift rail plug hole, while paying attention to its direction.
- (2) Line up the shift rail and shift fork spring pin hole and install the spring pin so that the slit of the spring pin will face the axial center of the shift rail.

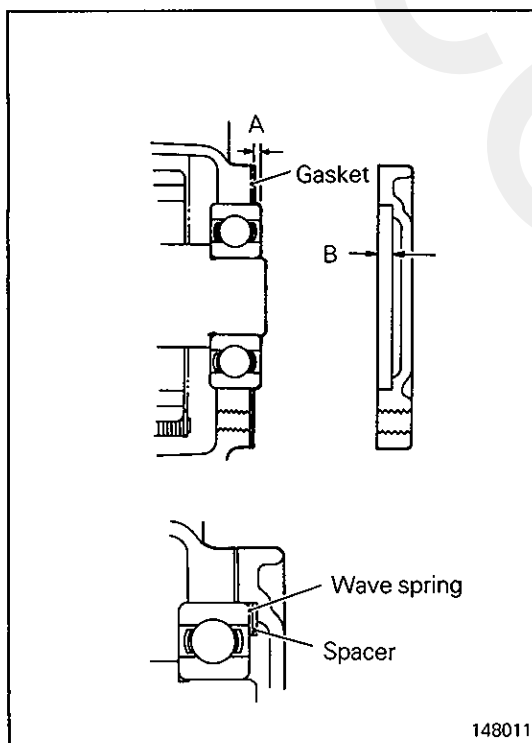

**P** INSTALLATION OF COVER, WAVE SPRING (SPACER)

- (1) Measure projection "A" of the front output shaft rear bearing and depth "B" of the cover.  
If subtraction of A from B makes more than 2 mm, add a spacer between the wave spring and cover.  
If the subtracted value is 2 mm or less, the wave spring only is enough.
- (2) Apply a sealant to the cover and mounting bolt thread before installation.

**Specified sealant:**

**Mitsubishi genuine sealant Part No. 997740 or equivalent** ..... **Cover**  
**3M STUD Locking No. 4170 or equivalent** ..... **Bolt**

**Caution**

- Squeeze the sealant out evenly to make sure that it is not broken or excessively supplied.

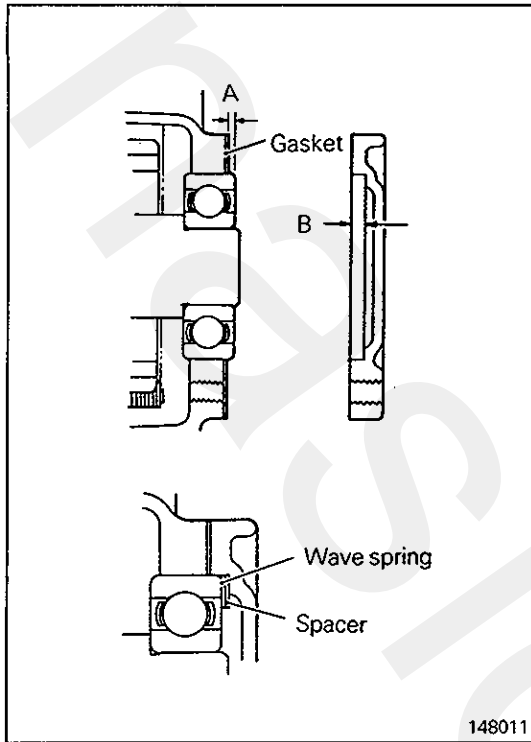

### ◆Q◆ INSTALLATION OF COVER GASKET, COVER

- (1) Measure the projection (A) of the rear bearing from the end of the front output shaft and the depth (B) of indentation in the cover.

If the clearance (a difference between A and B) exceeds 2 mm, insert a spacer between the cover and the wave spring. If the clearance is 2 mm or less, use the wave spring alone.

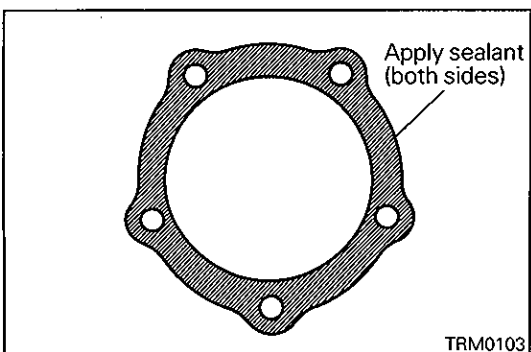
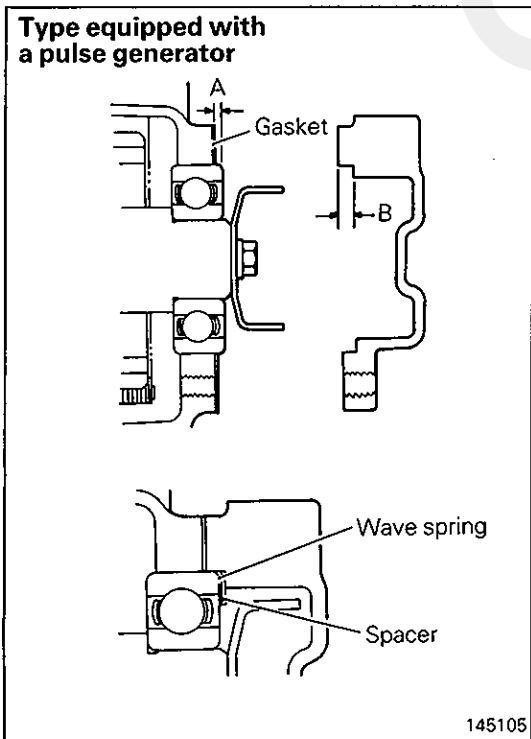

- (2) Apply specified sealant to both sides of the cover gasket.

#### Specified sealant:

**Mitsubishi genuine sealant Part No. 997740 or equivalent**



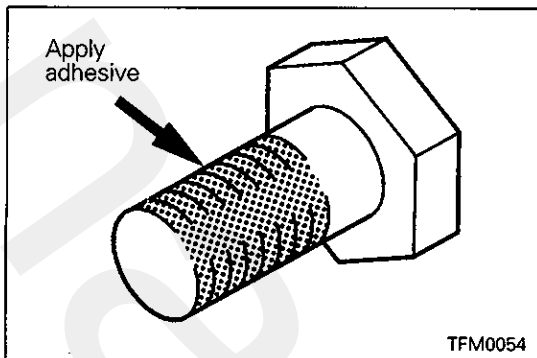

- (3) Install the cover.
- (4) Apply the specified adhesive to the threaded part of the cover installation bolt.

**Specified adhesive:**  
**3M STUD Locking No. 4170 or equivalent**

- (5) Tighten the cover installation bolt at the specified torque.

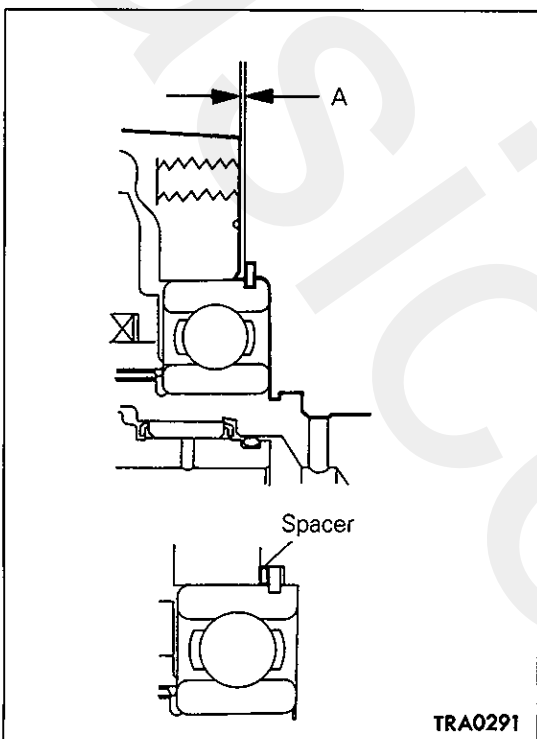

**▶R◀ INSTALLATION OF SNAP RING, SPACER (Up to November 1992)**

- (1) Measure clearance "A" between the ball bearing snap ring and the chain cover. Select a spacer of the thickness equivalent to the sum of measured value "A" and the following value.

**Standard value: 0.025 – 0.150 mm ( 0.00098 – 0.00591 in.)**

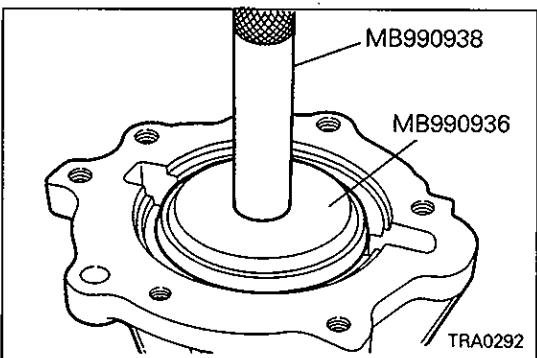

**▶S◀ INSTALLATION OF OIL SEAL**

- (1) Apply transmission oil to the lip of the oil seal before press-fitting.

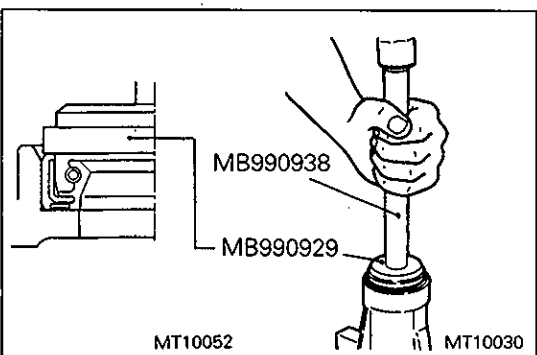

**▶T◀ INSTALLATION OF OIL SEAL**

- (1) Apply transmission oil to the lip of the oil seal before press-fitting.

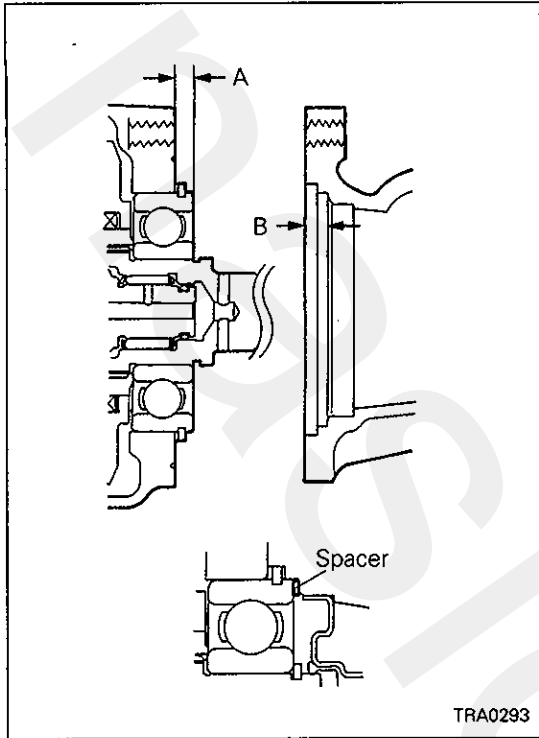

**U INSTALLATION OF SPACER, REAR COVER**

- (1) Measure projection "A" of the rear output shaft bearing and depth "B" of the second stage of the rear cover. Subtract A from B and let the answer be C. Subtract the thickness of the spacer from C, and select a spacer so that the subtracted value will be the standard value shown below.

**Standard value: 0 – 0.1 mm (0 – 0.0039 in.)**

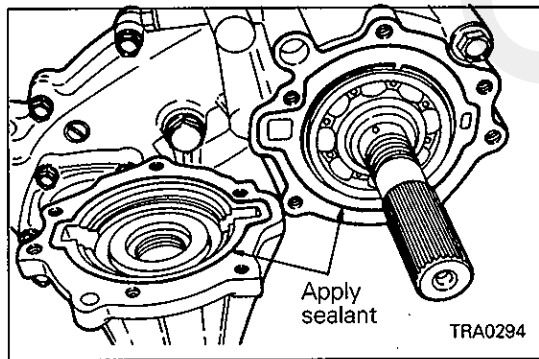

- (2) Apply a sealant to the rear cover and mounting bolt thread (case through bolts only) before installation.

**Specified sealant:**

**Mitsubishi genuine sealant Part No. 997740 or equivalent** ..... Cover  
**3M STUD Locking No. 4170 or equivalent** .... Bolts

**Caution**

- Squeeze the sealant out evenly to make sure that it is not broken or excessively supplied.

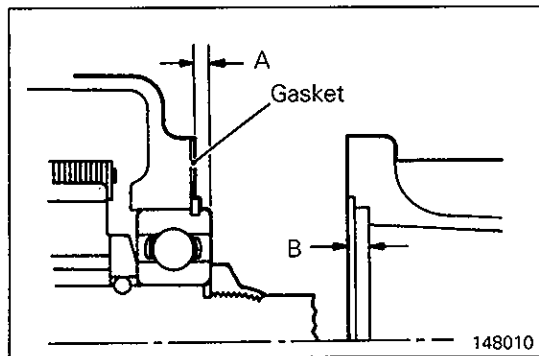

**V INSTALLATION OF SPACER, REAR COVER GASKET, REAR COVER**

- (1) Measure the amount of protrusion of the rear output shaft rear bearing "A" and the amount of inset in the cover "B". Select a spacer which adjusts the end play to the standard value.

**Standard value: 0 – 0.1 mm (0 – 0.0039 in.)**

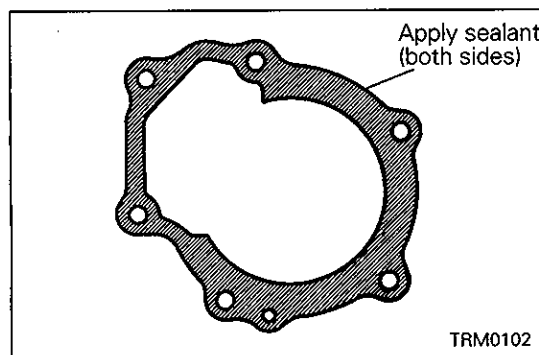

- (2) Apply sealant to both sides of the rear cover gasket.

**Specified sealant:**

**Mitsubishi genuine sealant Part No. 997740 or equivalent**

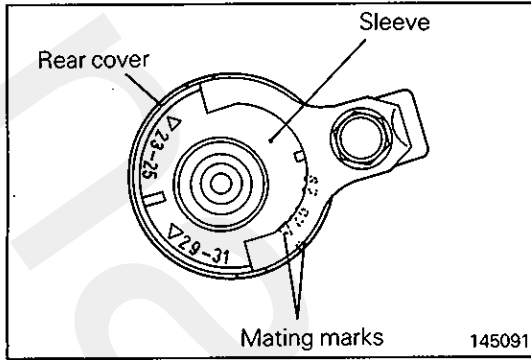

**W INSTALLATION OF SPEEDOMETER GEAR**

(1) Match the mating marks to the number of teeth.

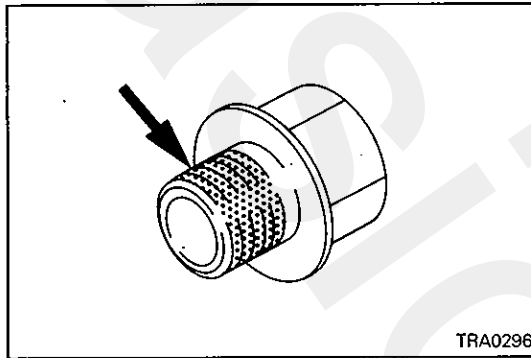

**X INSTALLATION OF POPPET PLUG**

(1) Apply a sealant to the poppet plug before installation.

**Specified sealant:**

**3M ATD Part No. 8660 or equivalent**

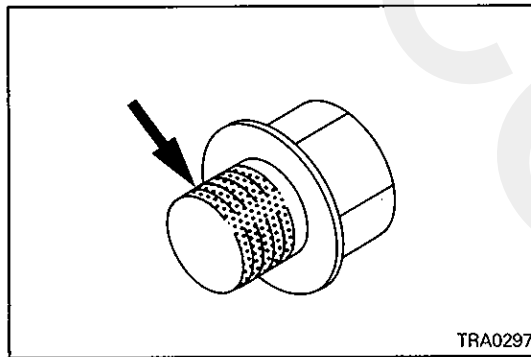

**Y INSTALLATION OF PLUG**

(1) The plug is a precoated one. When it is to be reused, apply a sealant to the plug beforehand.

**Specified sealant:**

**3M ATD Part No. 8660 or equivalent**

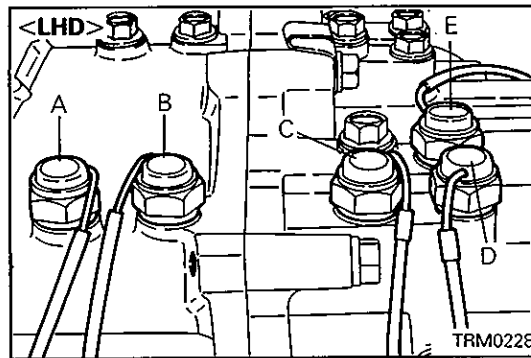

**Z INSTALLATION OF DETECTION SWITCH**

(1) Mount detection switch in the right positions, while using care to prevent confusion.

V4AW2-3, 7 (SUPER SELECT 4WD)

A: Ball built in, connector brown

B: Ball built in, connector black

C: Ball separate, connector brown

D: Ball separate, connector black

E: Ball separate, connector white

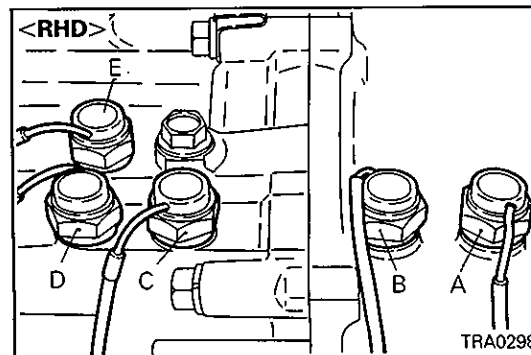

V4AW2-3, 7 (PART TIME 4WD)

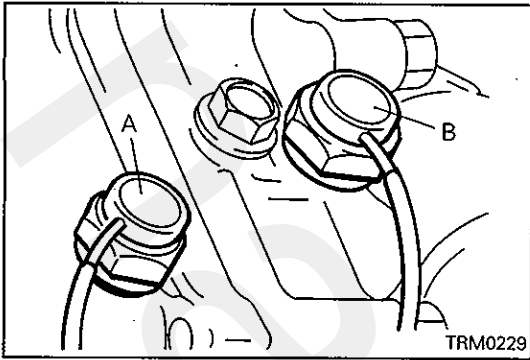
A: Ball built-in  
B: Ball separate

## ▶◀ INSTALLATION OF SPRING PIN

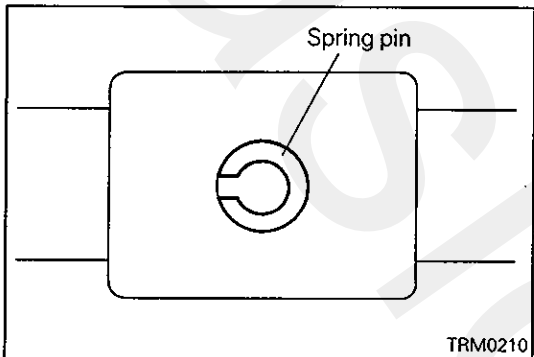

**17. REAR OUTPUT SHAFT <V4AW2-1, V4AW2-3, 7 (PART TIME 4WD)>**

**DISASSEMBLY AND REASSEMBLY**

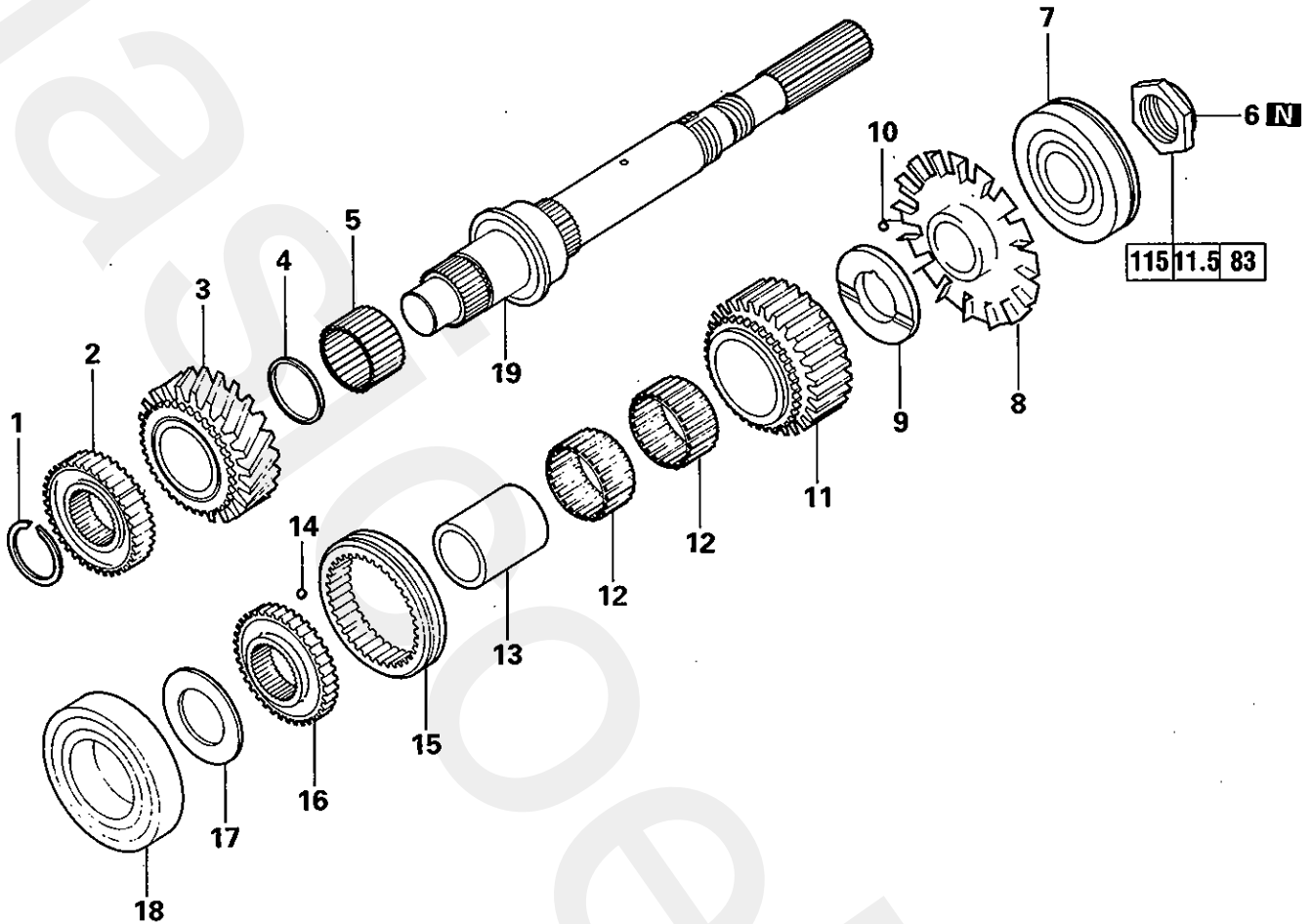

**Disassembly steps**

- |         |  |                         |                       |
|---------|--|-------------------------|-----------------------|
| ◆F◆     | 1. Snap ring                                   | 11. Drive sprocket      |                       |
| ◁A▷ ◆E◆ | 2. H-L clutch hub                              | 12. Needle bearing      |                       |
|         | 3. Low speed gear                              | 13. Sprocket sleeve     |                       |
|         | 4. Bearing spacer                              | 14. Steel ball          |                       |
|         | 5. Needle bearing                              | 15. 2-4WD clutch sleeve |                       |
| ◁B▷ ◆D◆ | 6. Lock nut                                    | ◁D▷ ◆B◆                 | 16. 2-4WD clutch hub  |
| ◁C▷ ◆C◆ | 7. Radial ball bearing                         | ◁D▷ ◆A◆                 | 17. Stopper plate     |
|         | 8. Oil guide <V4AW2-3, 7 (Part Time 4WD) only> | ◁D▷ ◆A◆                 | 18. Ball bearing      |
|         | 9. Sprocket spacer                             |                         | 19. Rear output shaft |
|         | 10. Steel ball                                 |                         |                       |

TRA0315

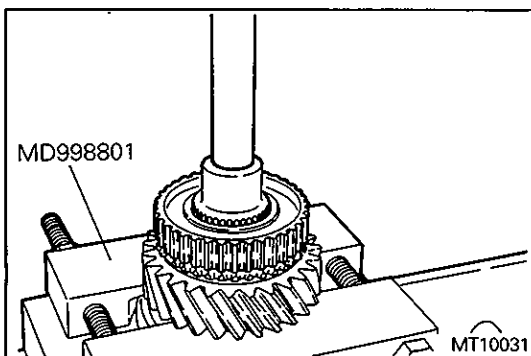

**SERVICE POINTS OF DISASSEMBLY**

**◁A▷ REMOVAL OF H-L CLUTCH HUB**

- (1) Set a special tool in such a way that the load will be placed on the low speed gear.
- (2) Press the rear output shaft front end with a press and remove the hub and gear.

**NOTE:**

The hub is loosely coupled with the shaft and may be removable without use of a press.

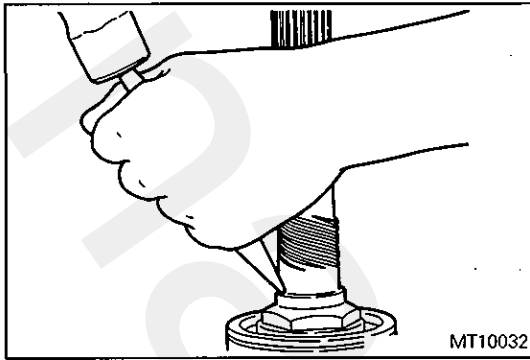

**◁B▷ REMOVAL OF LOCK NUT**

- (1) Hold the drive sprocket in a strapped vice.
- (2) Using a chisel, loosen the staked lock nut.

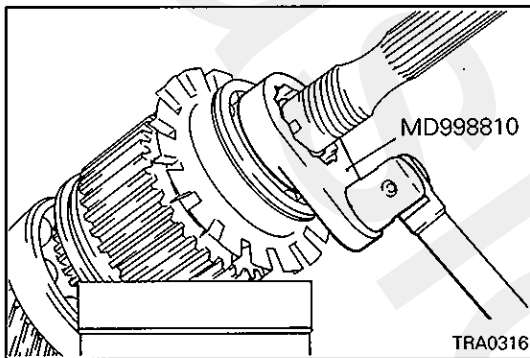

- (3) Place the clutch sleeve in mesh with the drive sprocket to prevent the rear output shaft from turning.
- (4) Using a special tool, remove the lock nut.

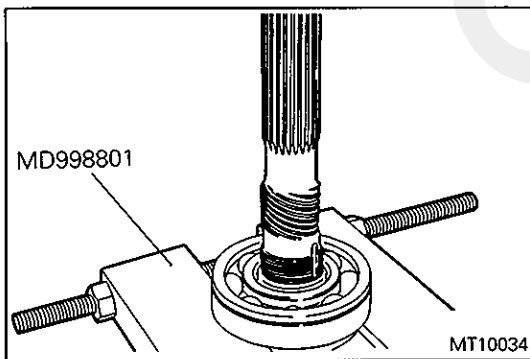

**◁C▷ REMOVAL OF RADIAL BALL BEARING**

**NOTE:**

The bearing is loosely coupled with the shaft and may be removable without use of a press.

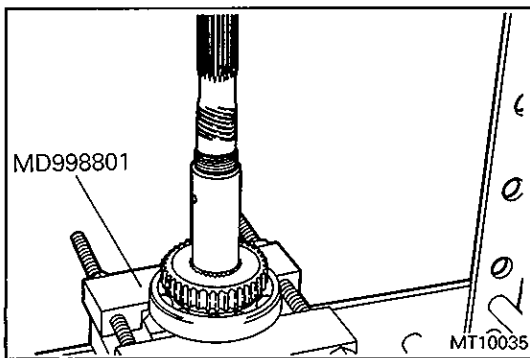

**◁D▷ REMOVAL OF 2-4WD CLUTCH HUB, STOPPER PLATE, BALL BEARING**

- (1) Set a special tool so that the load will be placed on the ball bearing.
- (2) Press the rear end of the rear output shaft with a press and remove the hub and bearing.

**NOTE:**

The hub is loosely coupled with the shaft and may be removal without use of a press.

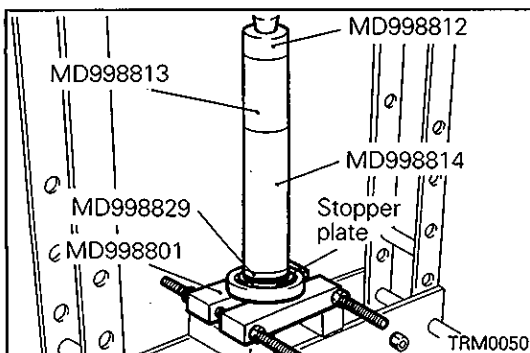

**SERVICE POINTS OF REASSEMBLY**

**▷A◁ INSTALLATION OF BALL BEARING, STOPPER PLATE**

- (1) Place the stopper plate on the ball bearing.
- (2) Using a special tool, install the ball bearing on the rear output shaft.

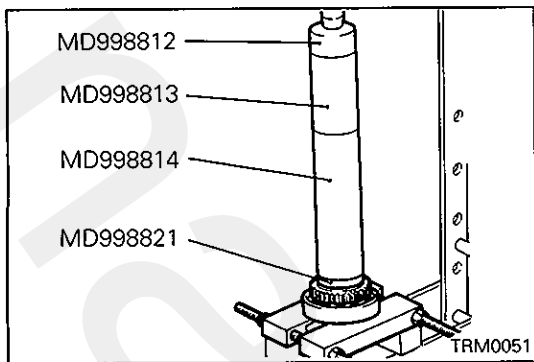

**▶B◀ INSTALLATION OF 2-4WD CLUTCH HUB**

- (1) Install the hub on the rear output shaft in the direction shown in the illustration.

**NOTE:**

The hub is loosely coupled with the shaft and may be mountable without use of a press.

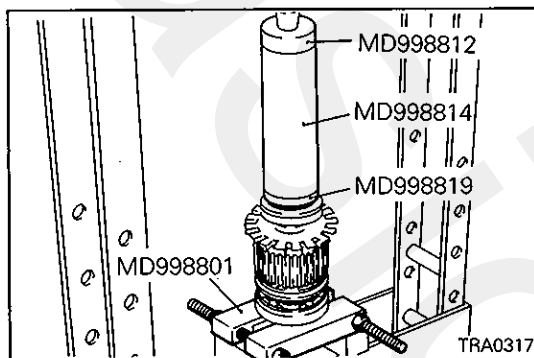

**▶C◀ INSTALLATION OF RADIAL BALL BEARING**

**NOTE:**

The hub is loosely coupled with the shaft and may be mountable without use of a press.

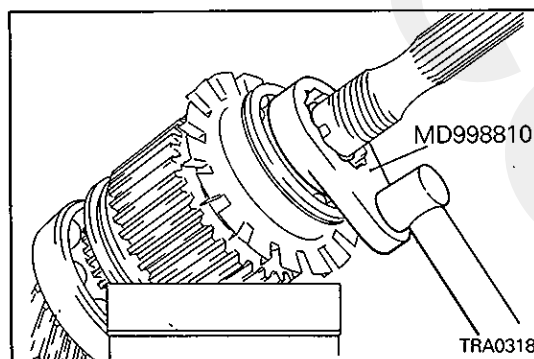

**▶D◀ INSTALLATION OF LOCK NUT**

- (1) Using a special tool and torque wrench, tighten the lock nut to the specified torque.
- (2) Using a punch, stake the lock nut in the groove of the rear output shaft.

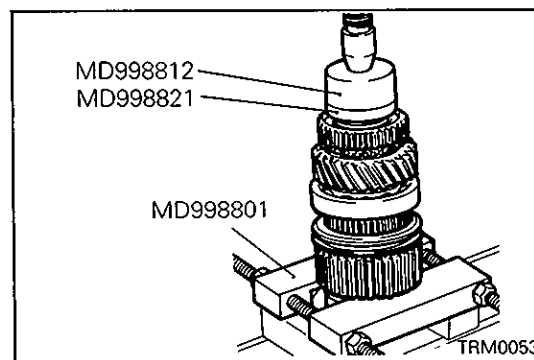

**▶E◀ INSTALLATION OF H-L CLUTCH HUB**

- (1) Install the hub on the rear output shaft in the direction shown in the illustration.

**NOTE:**

The hub is loosely coupled with the shaft and may be mountable without use of a press.

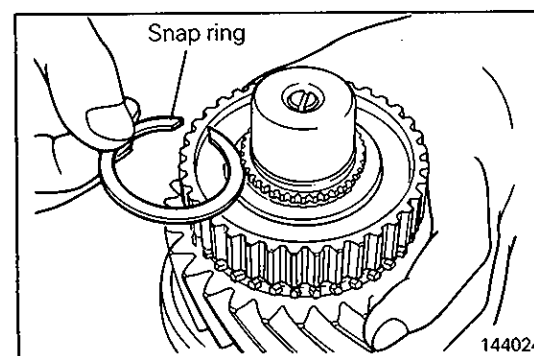

**▶F◀ INSTALLATION OF SNAP RING**

- (1) Select and mount the thickest snap ring that can fit in the groove.

**Standard value: 0 – 0.08 mm (0 – 0.003 in.)**

University of Cambridge



# 18. REAR OUTPUT SHAFT <V4AW2-3, 7 (SUPER SELECT 4WD)> DISASSEMBLY AND REASSEMBLY

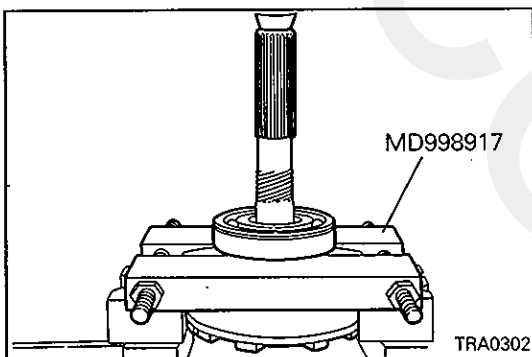
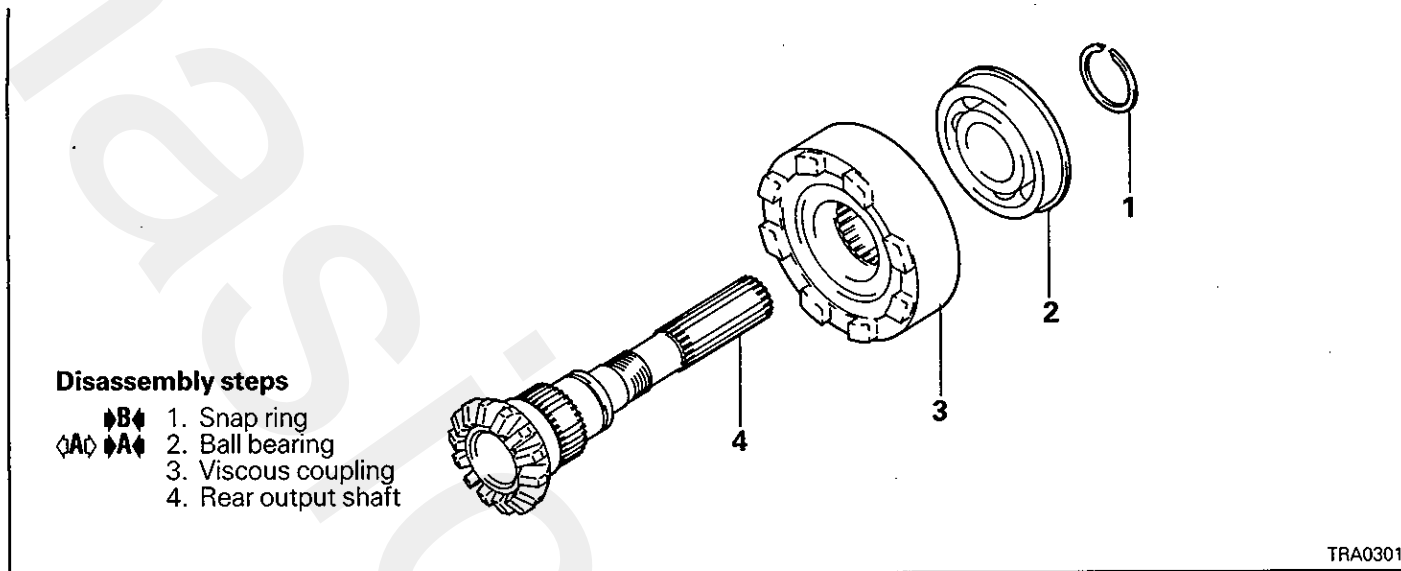

## SERVICE POINT OF DISASSEMBLY

◇A◇ REMOVAL OF BALL BEARING

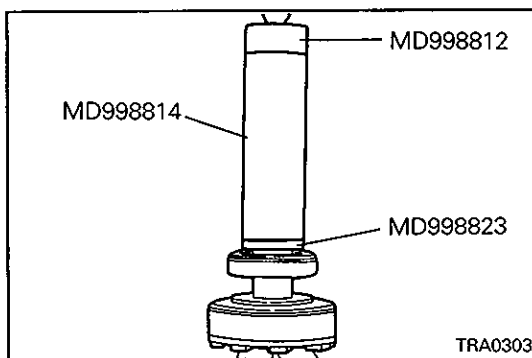

## SERVICE POINTS OF REASSEMBLY

◆A◆ INSTALLATION OF BALL BEARING

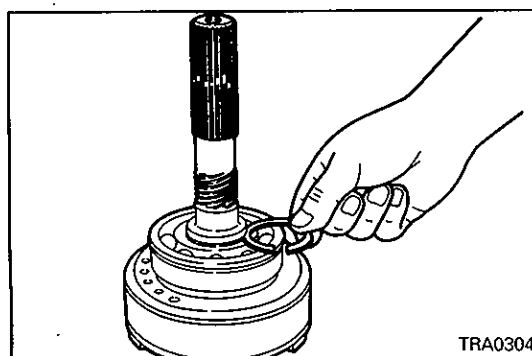

## ◆B◆ INSTALLATION OF SNAP RING

(1) Select and mount the thickest snap ring that can fit in the groove.

**Standard value: 0 – 0.08 mm (0 – 0.003 in.)**

University of Cambridge

# 19. CENTER DIFFERENTIAL CASE <V4AW2-3, 7 (SUPER SELECT 4WD) only>

## DISASSEMBLY AND REASSEMBLY

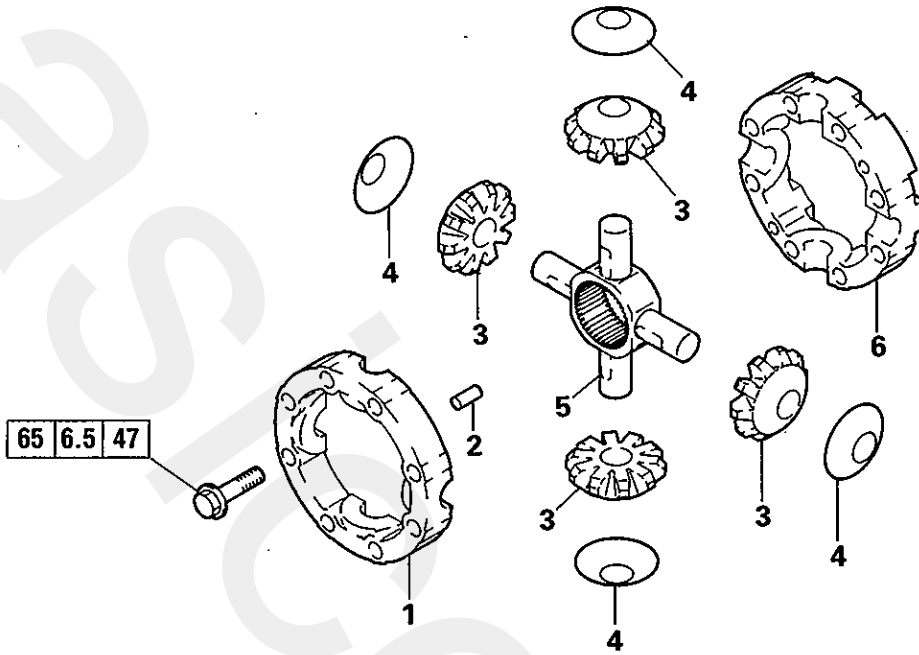

### Disassembly steps

- ◆◆ 1. Center differential case front
- 2. Dowel pin
- 3. Pinion
- 4. Thrust washer
- 5. Pinion shaft
- 6. Center differential case rear

TRA0305

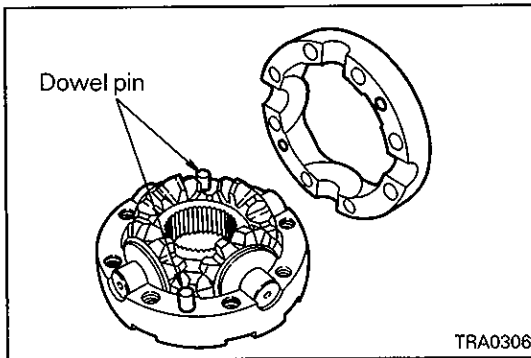

TRA0306

### SERVICE POINT OF REASSEMBLY

- ◆◆ **INSTALLATION OF CENTER DIFFERENTIAL CASE**
- (1) Pay attention to the positions of the dowel pins when reassembling, and make sure that the alignment marks on the outside circumference are in alignment.

University of Cambridge

## 20. 2-4WD SYNCHRONIZER <V4AW2-3, 7 (SUPER SELECT 4WD) only>

### DISASSEMBLY AND REASSEMBLY

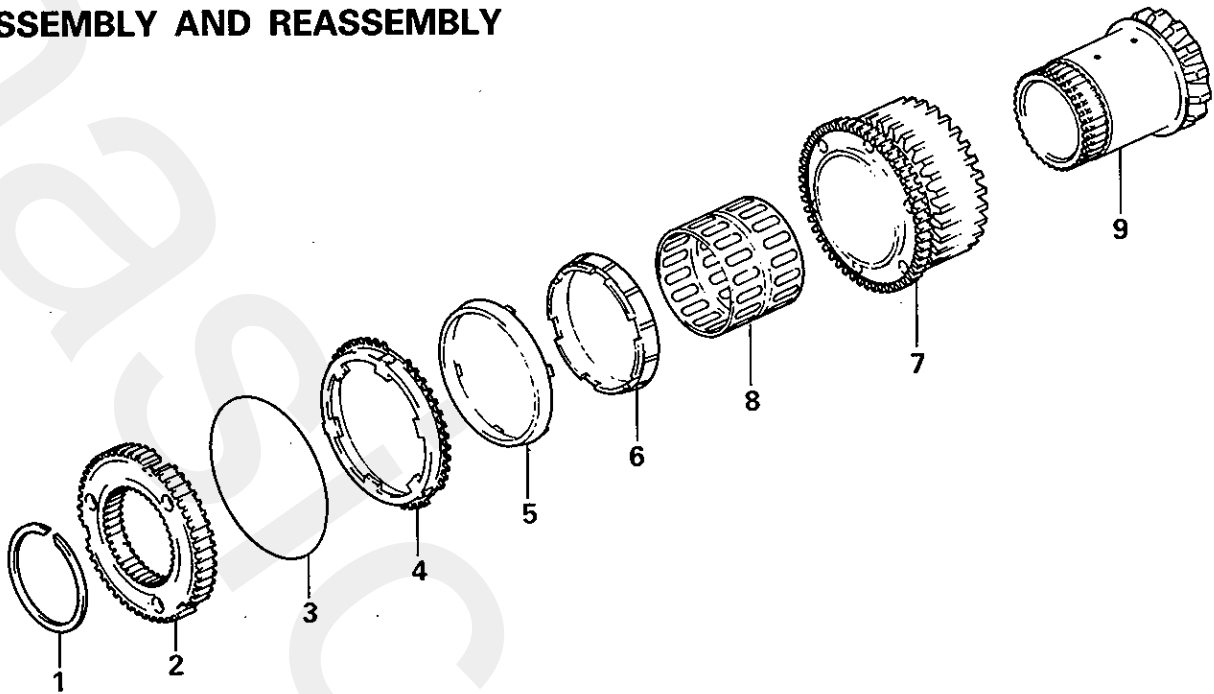

#### Disassembly steps

- ◆C◆ 1. Snap ring
- 2. 2-4WD synchronizer hub
- 3. Synchronizer spring
- ◆B◆ 4. Outer synchronizer ring
- 5. Synchronizer center cone
- ◆A◆ 6. Inner synchronizer ring
- 7. Drive sprocket
- 8. Needle bearing
- 9. Front drive pinion

TRA0307

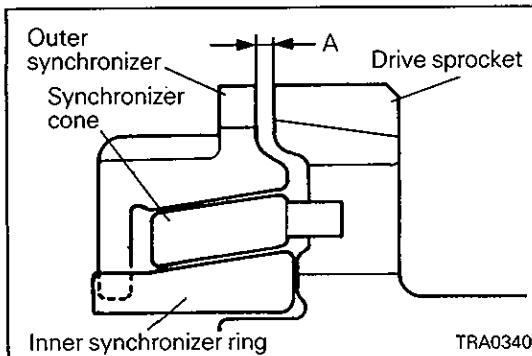

### INSPECTION

#### SYNCHRONIZER RING, SYNCHRONIZER CONE

- (1) Combine the inner and outer synchronizer rings and cone with the drive sprocket and measure the dimension A in the illustration. If the dimension A is less than the limit, replace them as a set.

**Limit: 0.3 mm (0.0118 in.)**

#### NOTE:

Scratches are produced on the cone surface in the rotating direction by the liners of the synchronizer rings. Therefore, the parts need not be replaced if the above-mentioned clearance is satisfied.

### SERVICE POINT OF REASSEMBLY

#### ▶A▶ INSTALLATION OF INNER SYNCHRONIZER RING

- (1) Apply transmission fluid to the synchronizer ring cone surface before installation.

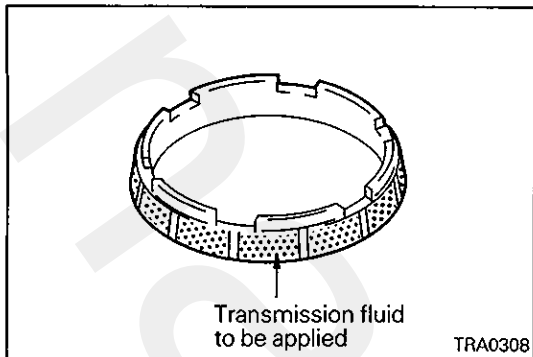

#### ▶B▶ INSTALLATION OF OUTER SYNCHRONIZER RING

- (1) Apply transmission fluid to the synchronizer ring cone surface before installation.

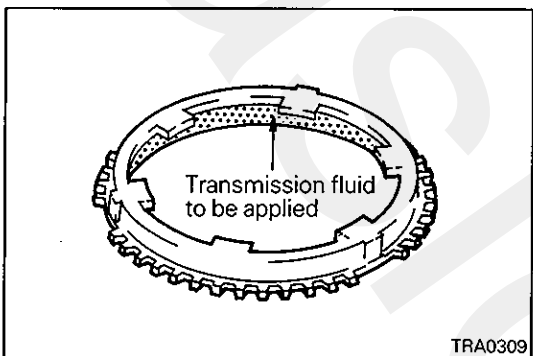

#### ▶C▶ INSTALLATION OF SNAP RING

- (1) Select and mount the thickest snap ring that can fit in the groove.

**Standard value: 0 – 0.08 mm (0 – 0.003 in.)**

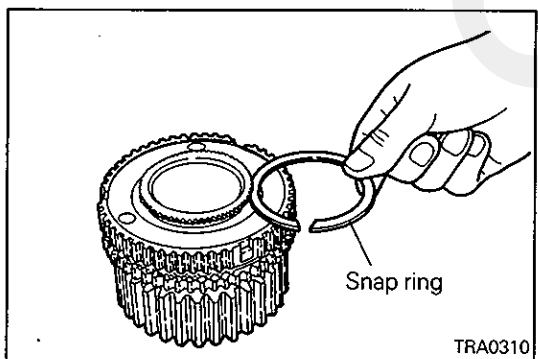

**21. TRANSFER DRIVE SHAFT <V4AW2-3, 7 (SUPER SELECT 4WD) only>**

**DISASSEMBLY AND REASSEMBLY**

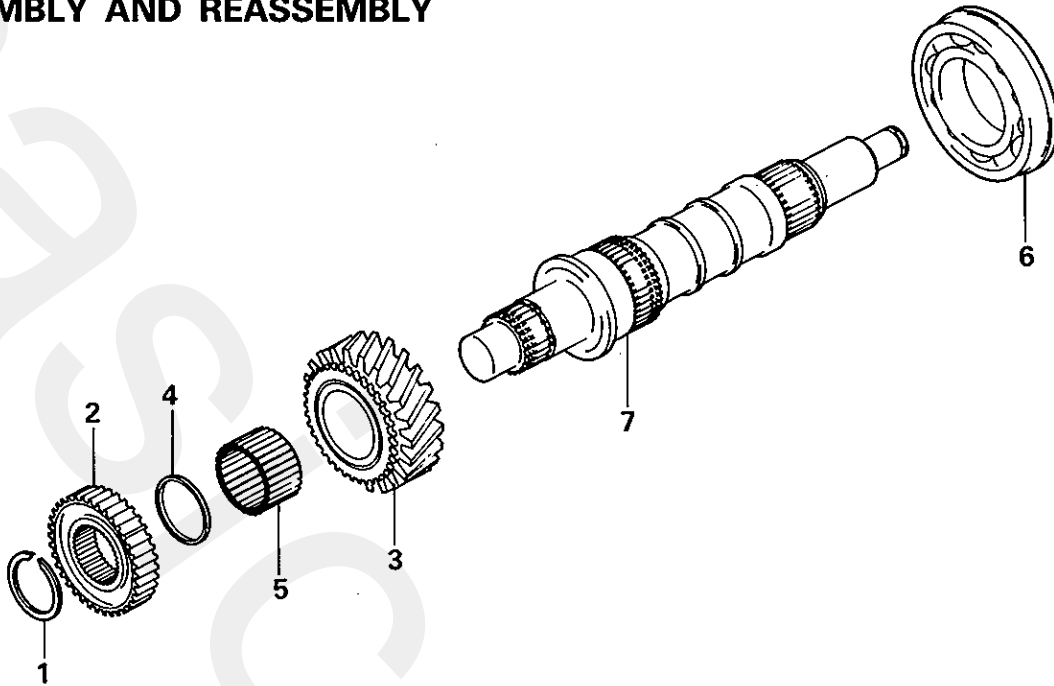

**Disassembly steps**

- ▶B▶ 1. Snap ring
- 2. H-L clutch hub
- 3. Low speed gear
- 4. Bearing spacer
- 5. Needle bearing
- ◁A▶▶A▶▶ 6. Ball bearing
- 7. Transfer drive shaft

TRA0311

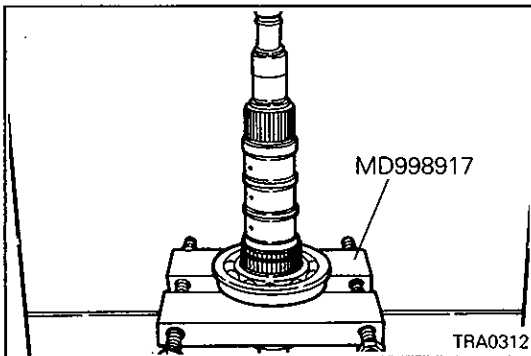

**SERVICE POINT OF DISASSEMBLY**

◁A▶ REMOVAL OF BALL BEARING

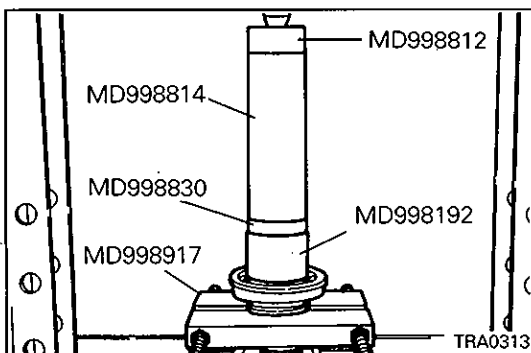

**SERVICE POINTS OF REASSEMBLY**

▶A▶ INSTALLATION OF BALL BEARING

**◆B◆ INSTALLATION OF SNAP RING**

- (1) Select and mount the thickest snap ring that can fit in the groove.

**Standard value: 0 – 0.08 mm (0 – 0.003 in.)**

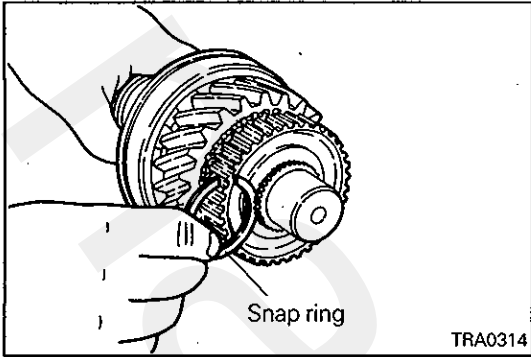



## 22. FRONT OUTPUT SHAFT DISASSEMBLY AND REASSEMBLY

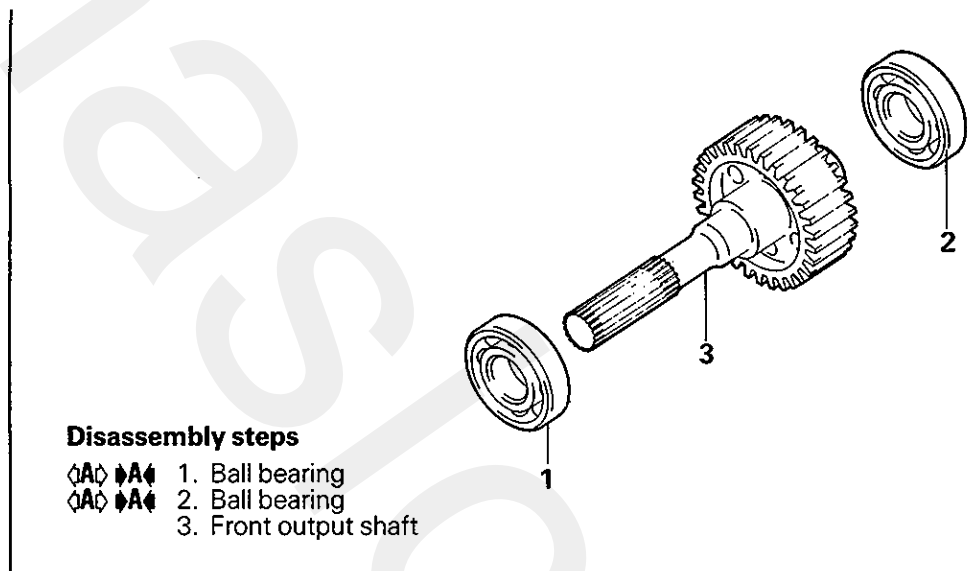

**Disassembly steps**

- ◁A▷ ▷A▷ 1. Ball bearing
- ◁A▷ ▷A▷ 2. Ball bearing
- 3. Front output shaft

TRA0319

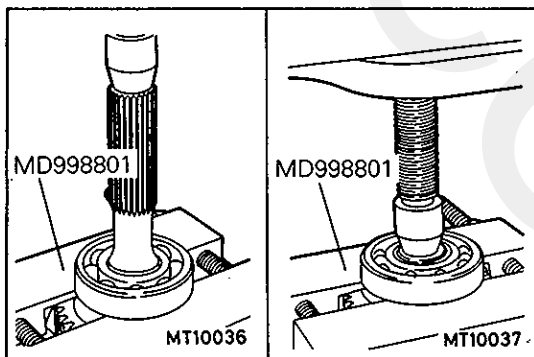

**SERVICE POINT OF DISASSEMBLY**

◁A▷ REMOVAL OF BALL BEARING

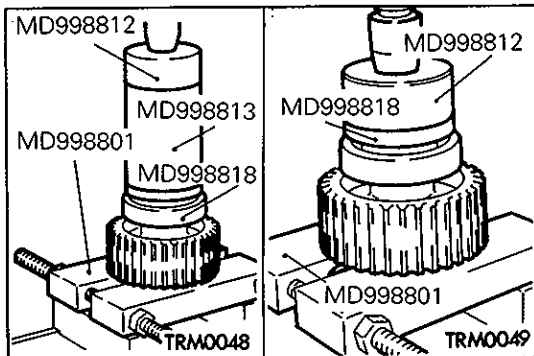

**SERVICE POINT OF REASSEMBLY**

◁A▷ INSTALLATION OF BALL BEARING

University of Cambridge

## 23. INPUT GEAR DISASSEMBLY AND REASSEMBLY

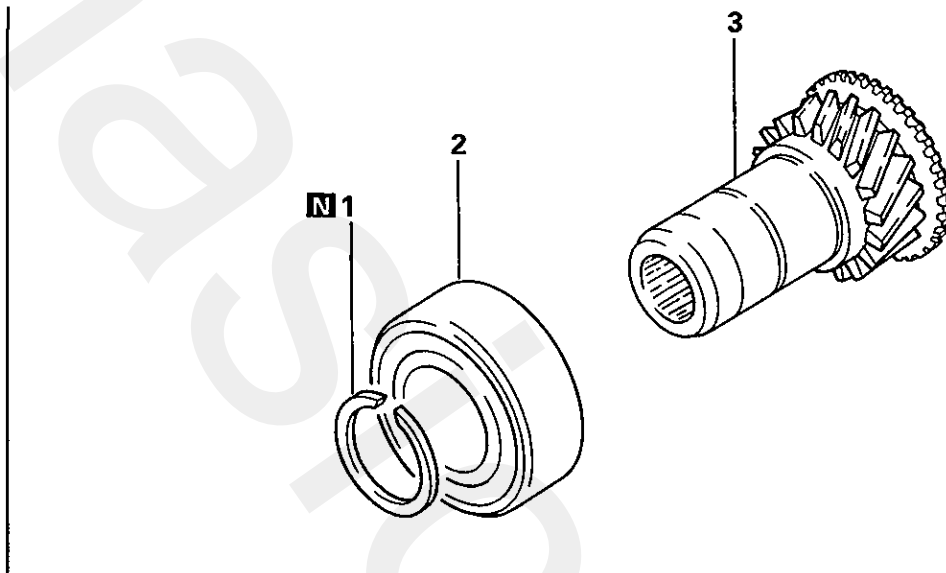

### Disassembly steps

- ◆B◆ 1. Snap ring
- ◁A◇ ◆A◆ 2. Bearing
- 3. Input gear

145086

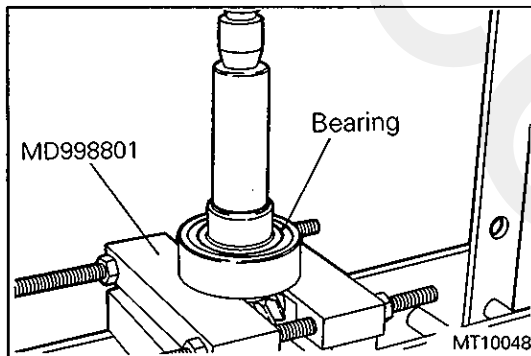

### SERVICE POINT OF DISASSEMBLY

- ◁A◇ REMOVAL OF BEARING

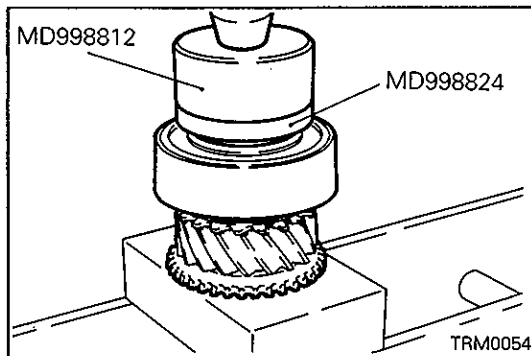

### SERVICE POINTS OF REASSEMBLY

- ◆A◆ INSTALLATION OF BEARING

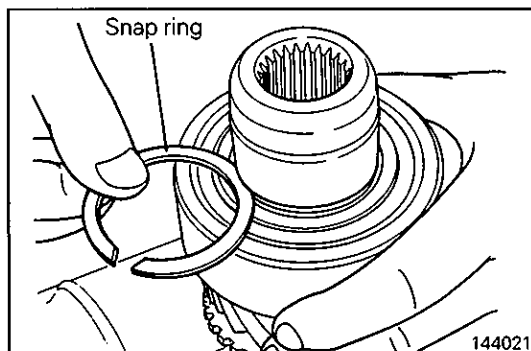

### ◆B◆ INSTALLATION OF SNAP RING

- (1) Select the thickest snap ring that will fit into the groove in the front end of the input gear and install it.

**Standard value: 0 – 0.06 mm (0 – 0.0024 in.)**

University of Cambridge

## 24. SPEEDOMETER SLEEVE DISASSEMBLY AND REASSEMBLY

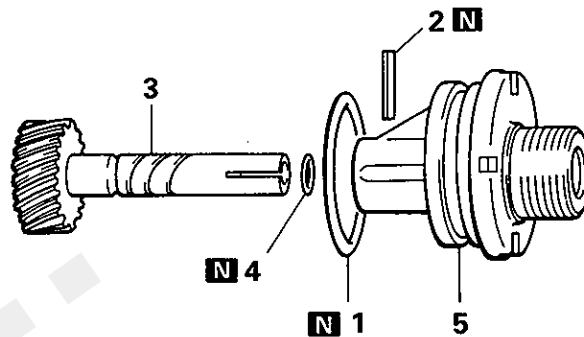

### Disassembly steps

- 1. O-ring
- ▶B▶ 2. Spring pin
- ▶A▶ 3. Speedometer driven gear
- 4. O-ring
- 5. Sleeve

110008

### SERVICE POINTS OF REASSEMBLY

#### ▶A▶ INSTALLATION OF SPEEDOMETER DRIVEN GEAR

- (1) Apply gear oil sparingly to the shaft of the speedometer driven gear before insertion.

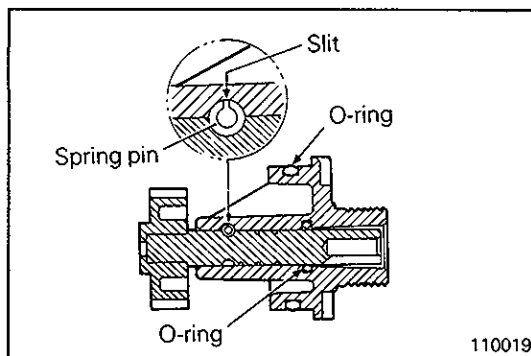

#### ▶B▶ INSTALLATION OF SPRING PIN

- (1) Drive the spring pin into position so that its slit faces the direction shown in the illustration.

University of Cambridge