



Fuller® Automated Transmissions

**Roadranger®**

More time on the road®

# Gen2 Electrical Wiring Schematics

---

Fuller Automated Transmissions

RRMT0009

October 2007

**This page intentionally left blank.**

---

**Table of Contents**

6-Speed and 7-Speed AutoShift Wiring Diagram ..... 1

6-Speed UltraShift ASW Wiring Diagram ..... 3

10-Speed AutoShift Wiring Diagram ..... 5

10-Speed UltraShift DM Wiring Diagram ..... 7

18-Speed AutoShift Wiring Diagram ..... 9

Eaton Shift Lever Wiring Diagram ..... 11

OEM Shift Lever Wiring Diagram ..... 12

# 6-Speed and 7-Speed AutoShift Wiring Diagram

## 6-Speed and 7-Speed AutoShift Wiring Diagram

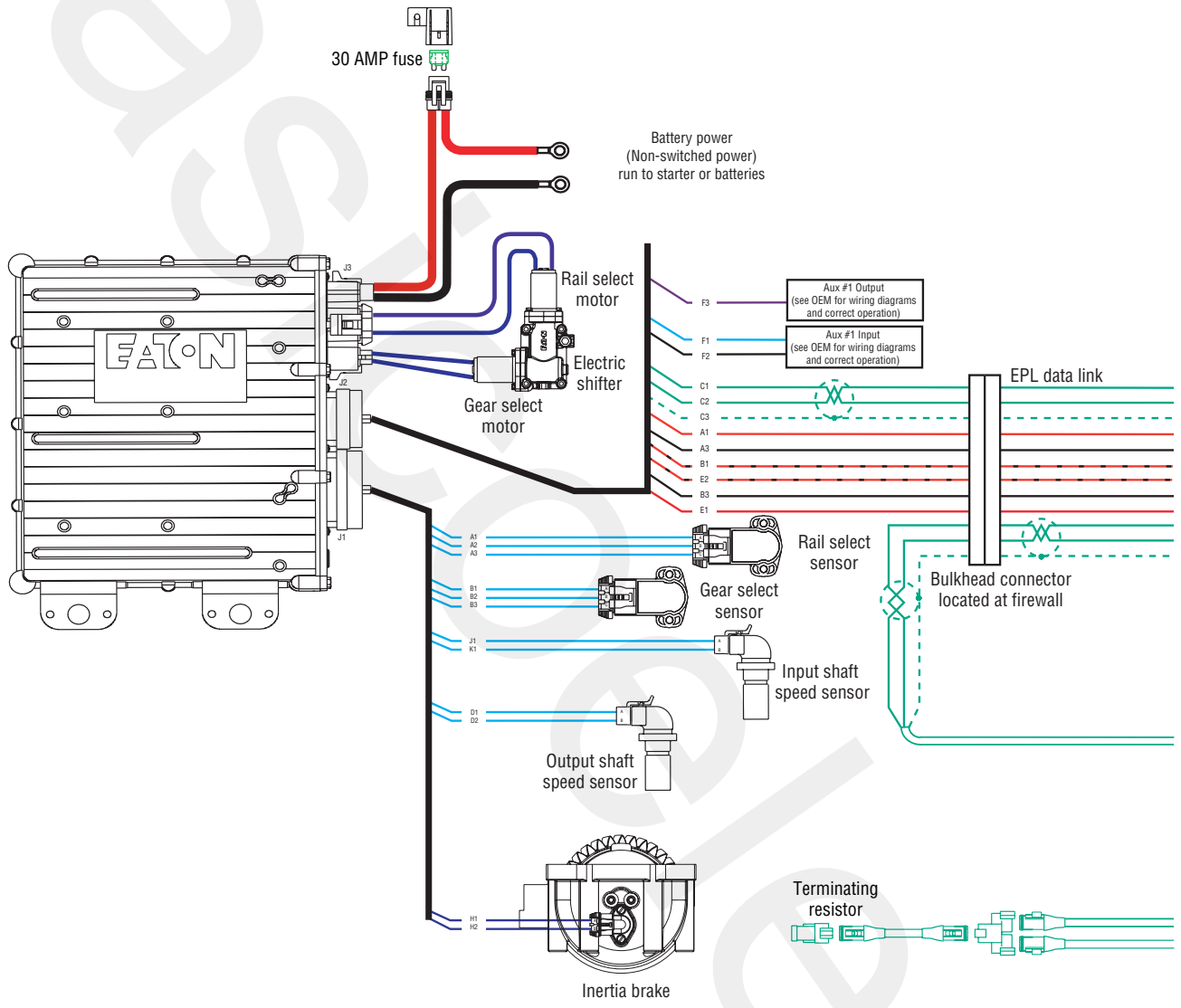

**Trans ECU Legend**  
 All OEM responsible wiring shown is "typical". Consult specific application.  
 (A1, E1) = +12 volt non-switched from battery  
 (B1, E2) = +12 volt switched from shift control to transmission controller  
 (F1) = Signals into the ECU  
 (C1, C2, C3, J-1939) = Communication from and to the ECU  
 (F2, A3, B3) = Signal returns, grounds, and general OEM wiring  
 (F3) = Aux output 1

# 6-Speed and 7-Speed AutoShift Wiring Diagram

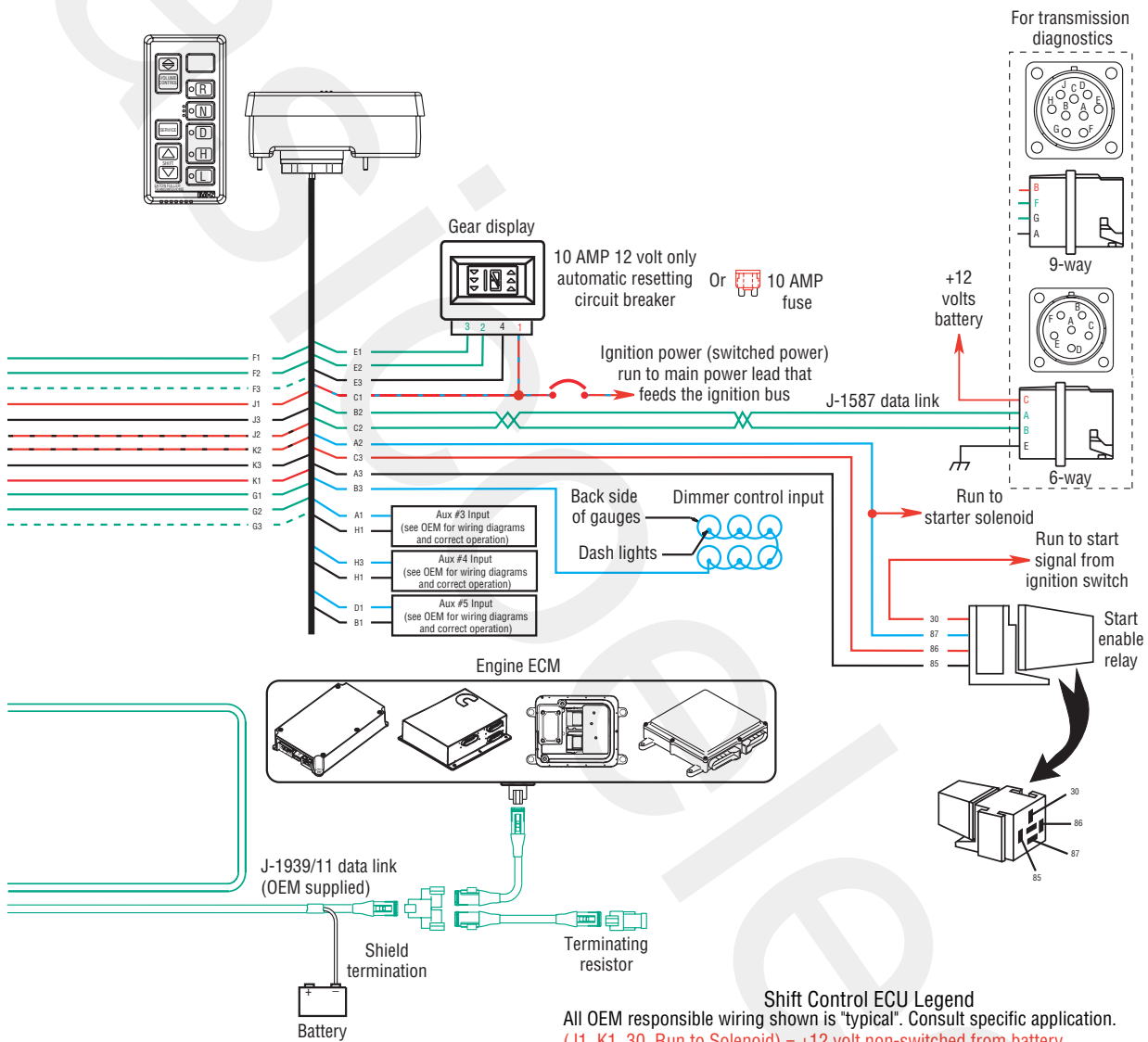

# 6-Speed UltraShift ASW Wiring Diagram

## 6-Speed UltraShift ASW Wiring Diagram

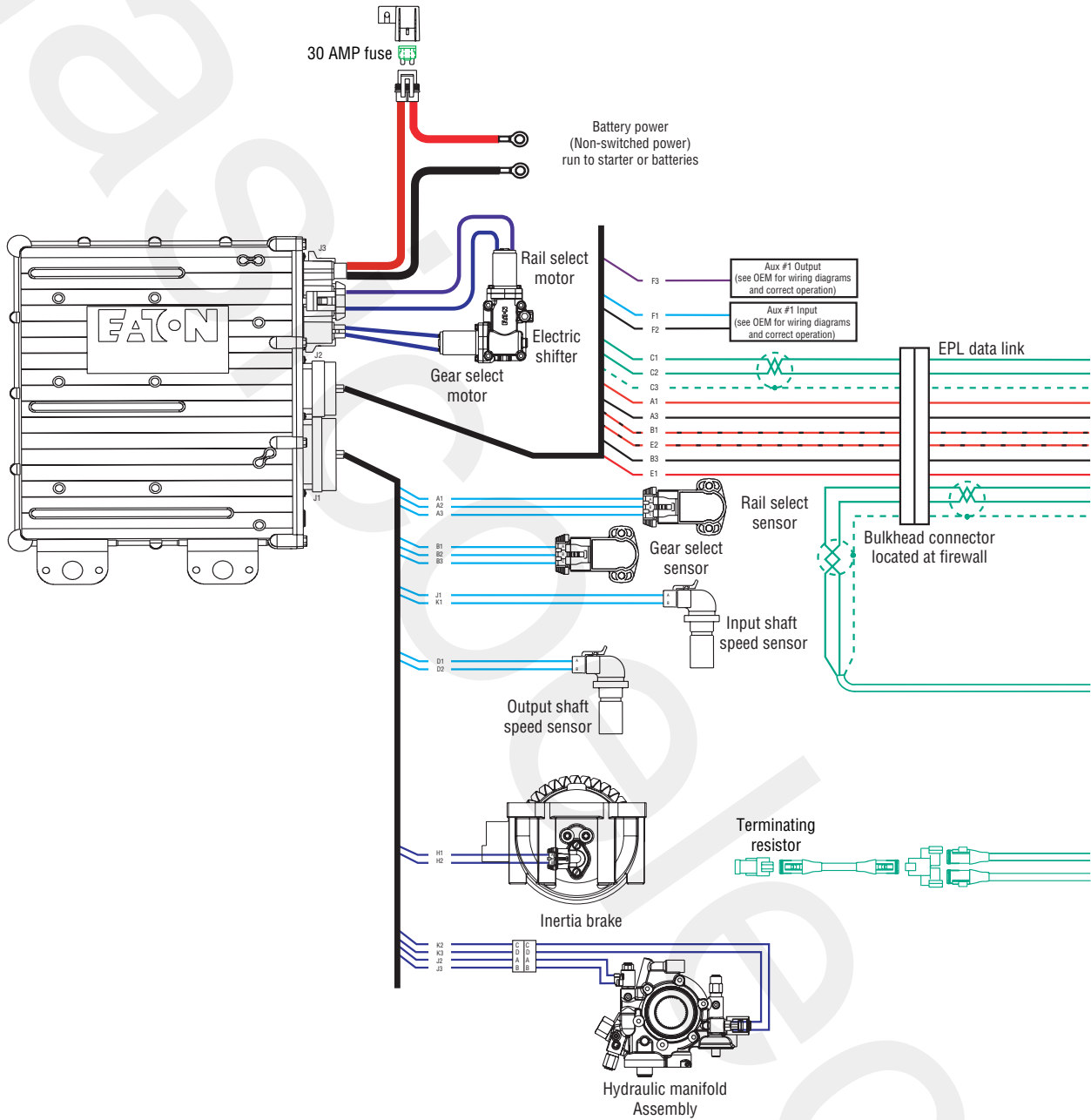

### Trans ECU Legend

All OEM responsible wiring shown is "typical". Consult specific application.  
 (A1, E1) = +12 volt non-switched from battery  
 (B1, E2) = +12 volt switched from shift control to transmission controller  
 (F1) = Signals into the ECU  
 (C1, C2, C3, J-1939) = Communication from and to the ECU  
 (F2, A3, B3) = Signal returns, grounds, and general OEM wiring  
 (F3) = Aux output 1

# 6-Speed UltraShift ASW Wiring Diagram

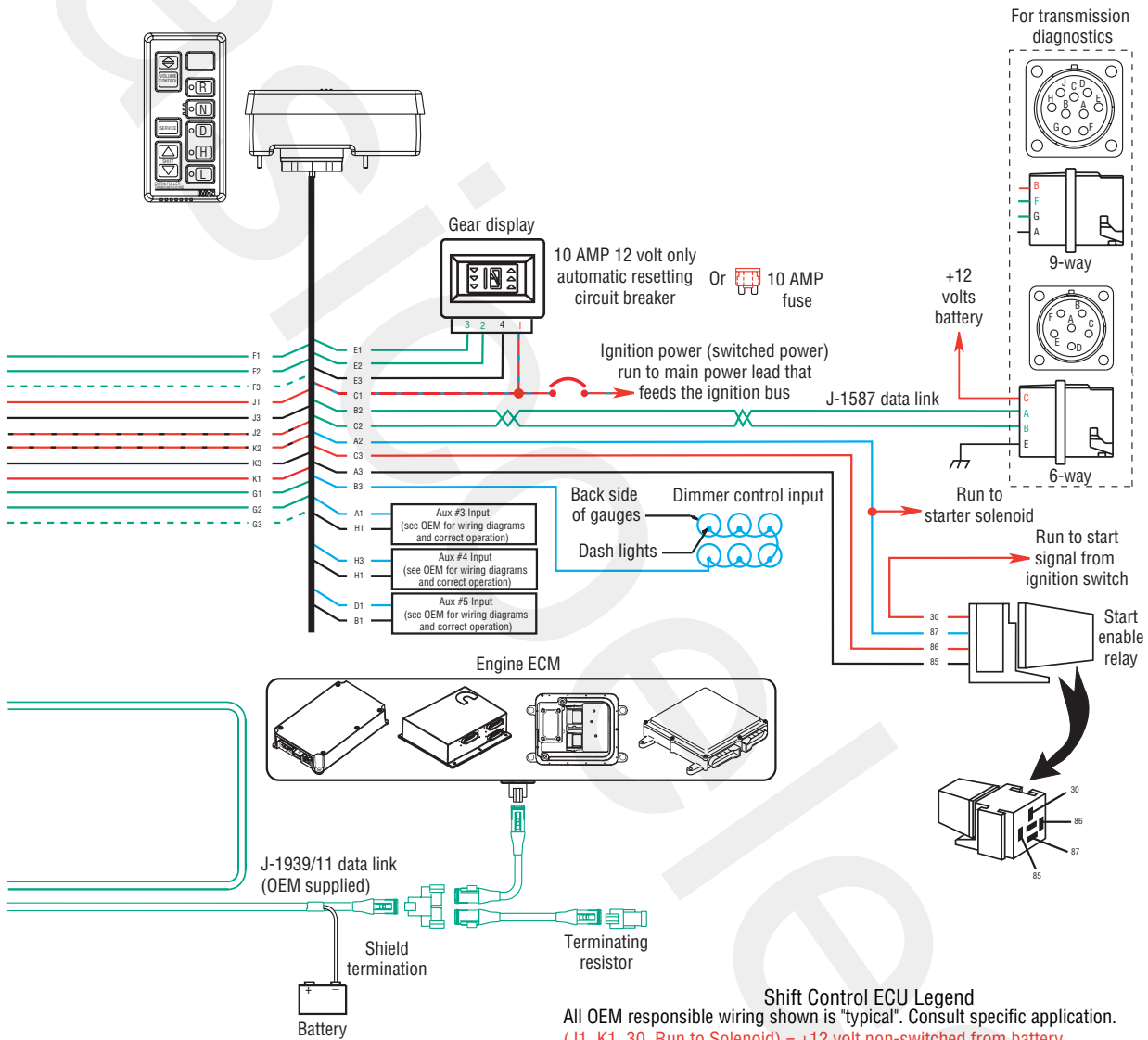

**Shift Control ECU Legend**  
 All OEM responsible wiring shown is "typical". Consult specific application.  
 (J1, K1, 30, Run to Solenoid) = +12 volt non-switched from battery  
 (J2, K2) = +12 volt switched from shift control to transmission controller  
 (C1) = +12 volt switched from ignition switch  
 (A2-87, B3, A1, H3, D1) = Signals into the ECU  
 (F1, F2, F3, G1, G2, G3, E1, E2, B2, C2, J-1939) = Communication from and to the ECU  
 (J3, K3, E3, H1, B1) = Signal returns, grounds, and general OEM wiring  
 (A3-85) = -12 volt relay source  
 (C3-86) = +12 volt relay source

# 10-Speed AutoShift Wiring Diagram

## 10-Speed AutoShift Wiring Diagram

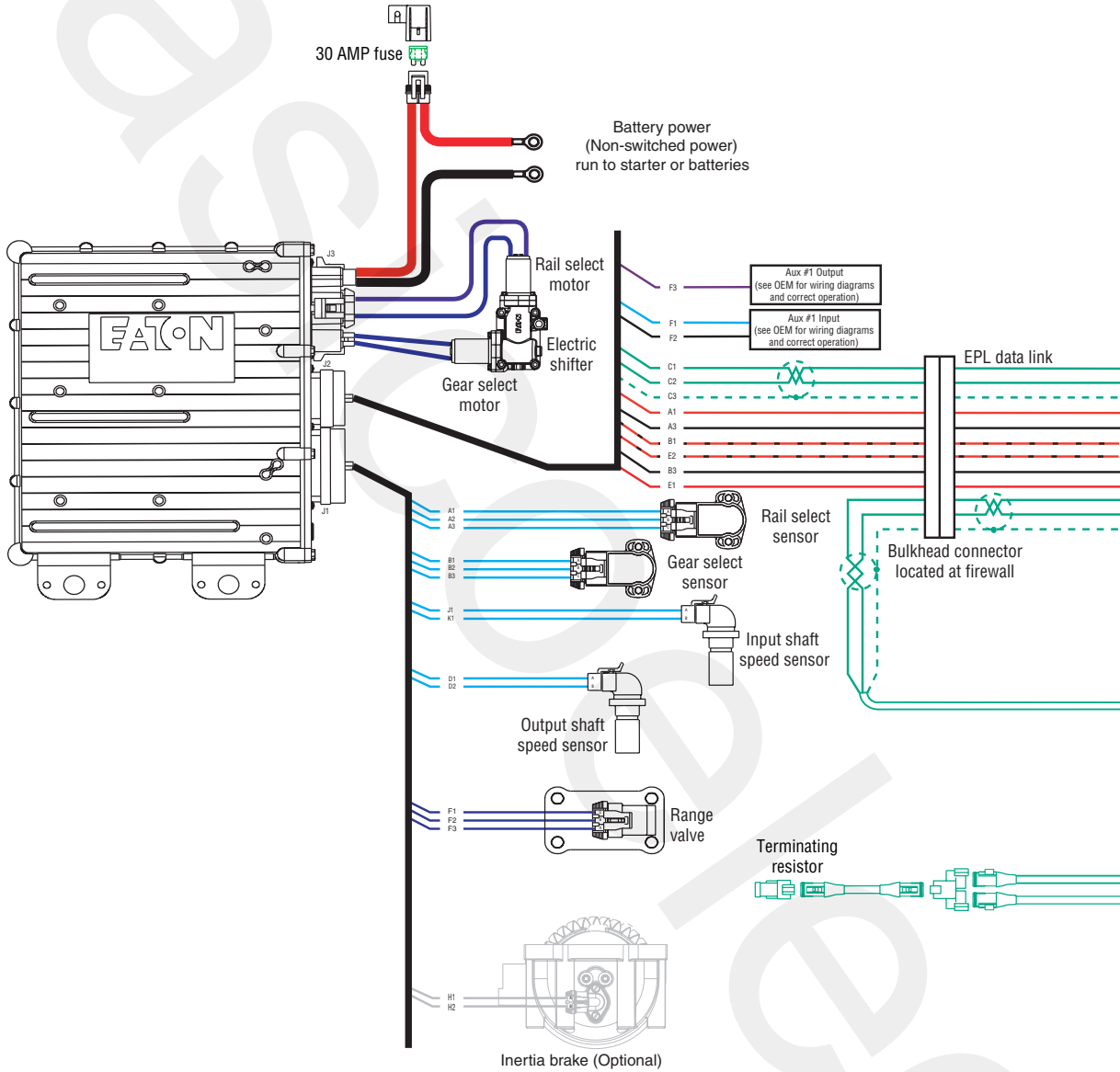

### Trans ECU Legend

- All OEM responsible wiring shown is "typical". Consult specific application.
- (A1, E1) = +12 volt non-switched from battery
- (B1, E2) = +12 volt switched from shift control to transmission controller
- (F1) = Signals into the ECU
- (C1, C2, C3, J-1939) = Communication from and to the ECU
- (F2, A3, B3) = Signal returns, grounds, and general OEM wiring
- (F3) = Aux output 1



# 10-Speed AutoShift Wiring Diagram

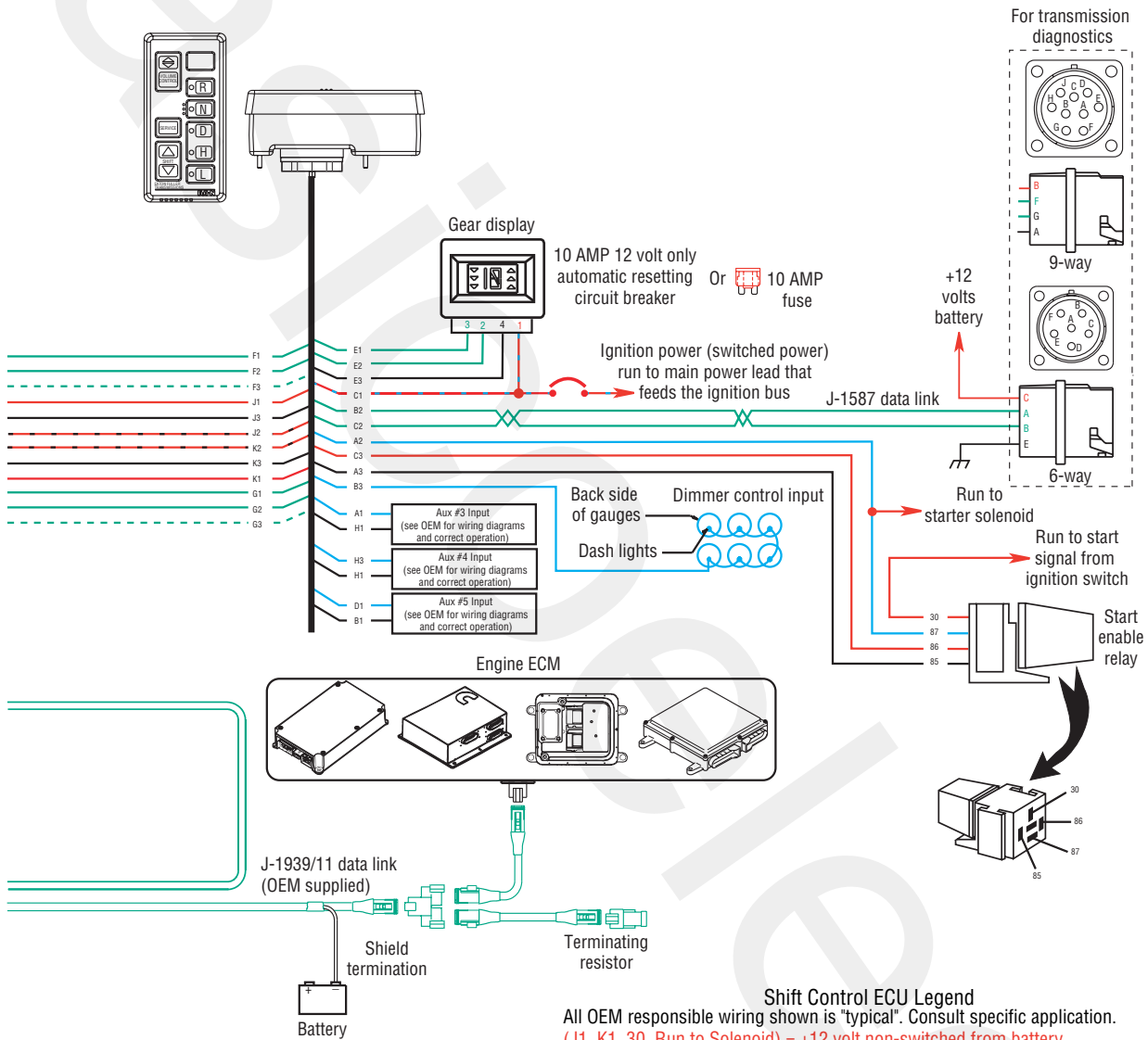

## Shift Control ECU Legend

All OEM responsible wiring shown is "typical". Consult specific application.

- (J1, K1, 30, Run to Solenoid) = +12 volt non-switched from battery
- (J2, K2) = +12 volt switched from shift control to transmission controller
- (C1) = +12 volt switched from ignition switch
- (A2-87, B3, A1, H3, D1) = Signals into the ECU
- (F1, F2, F3, G1, G2, G3, E1, E2, B2, C2, J-1939) = Communication from and to the ECU
- (J3, K3, E3, H1, B1) = Signal returns, grounds, and general OEM wiring
- (A3-85) = -12 volt relay source
- (C3-86) = +12 volt relay source

# 10-Speed UltraShift DM Wiring Diagram

## 10-Speed UltraShift DM Wiring Diagram

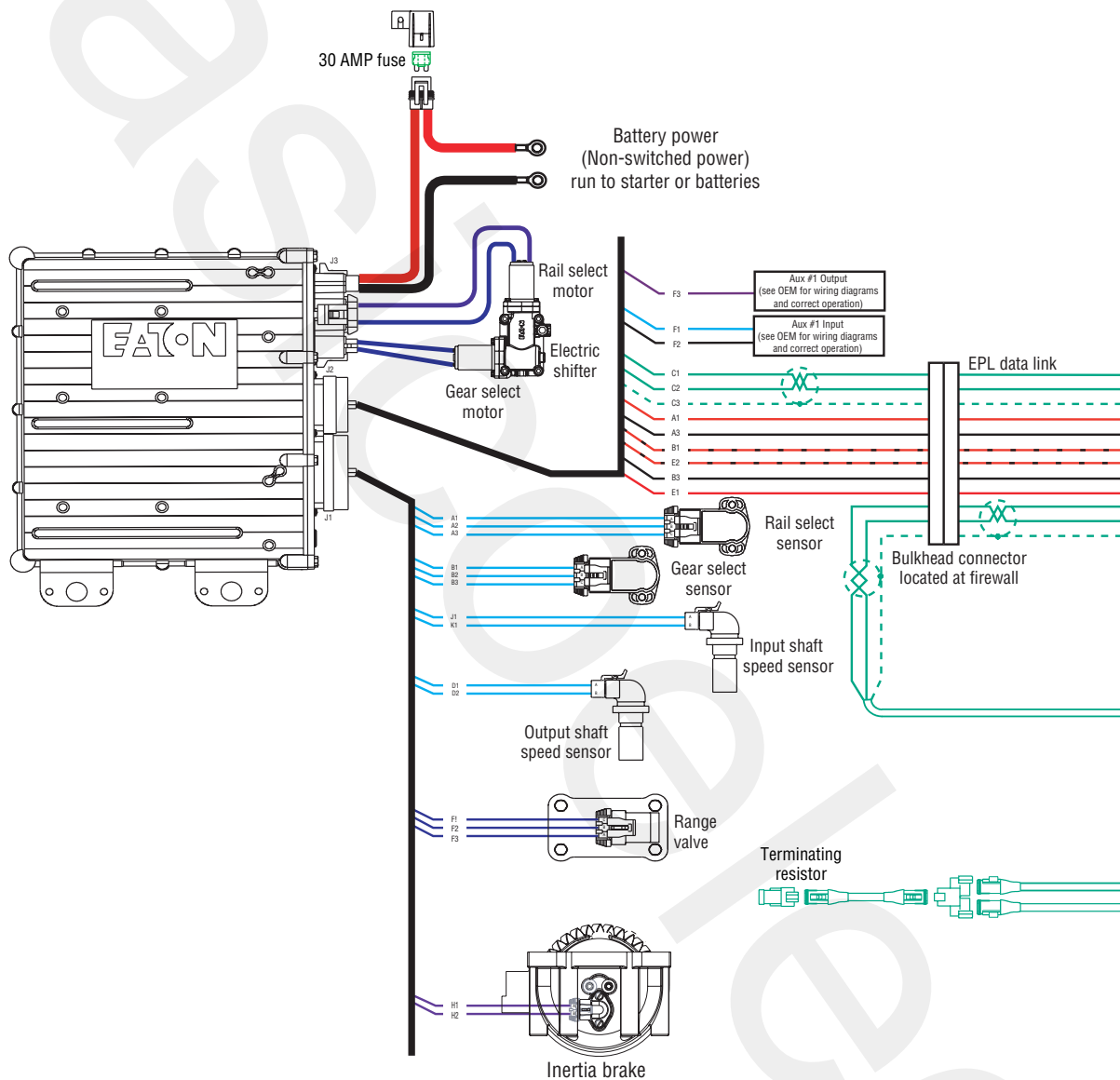

### Trans ECU Legend

All OEM responsible wiring shown is "typical". Consult specific application.

(A1, E1) = +12 volt non-switched from battery

(B1, E2) = +12 volt switched from shift control to transmission controller

(F1) = Signals into the ECU

(C1, C2, C3, J-1939) = Communication from and to the ECU

(F2, A3, B3) = Signal returns, grounds, and general OEM wiring

(F3) = Aux output 1

# 10-Speed UltraShift DM Wiring Diagram

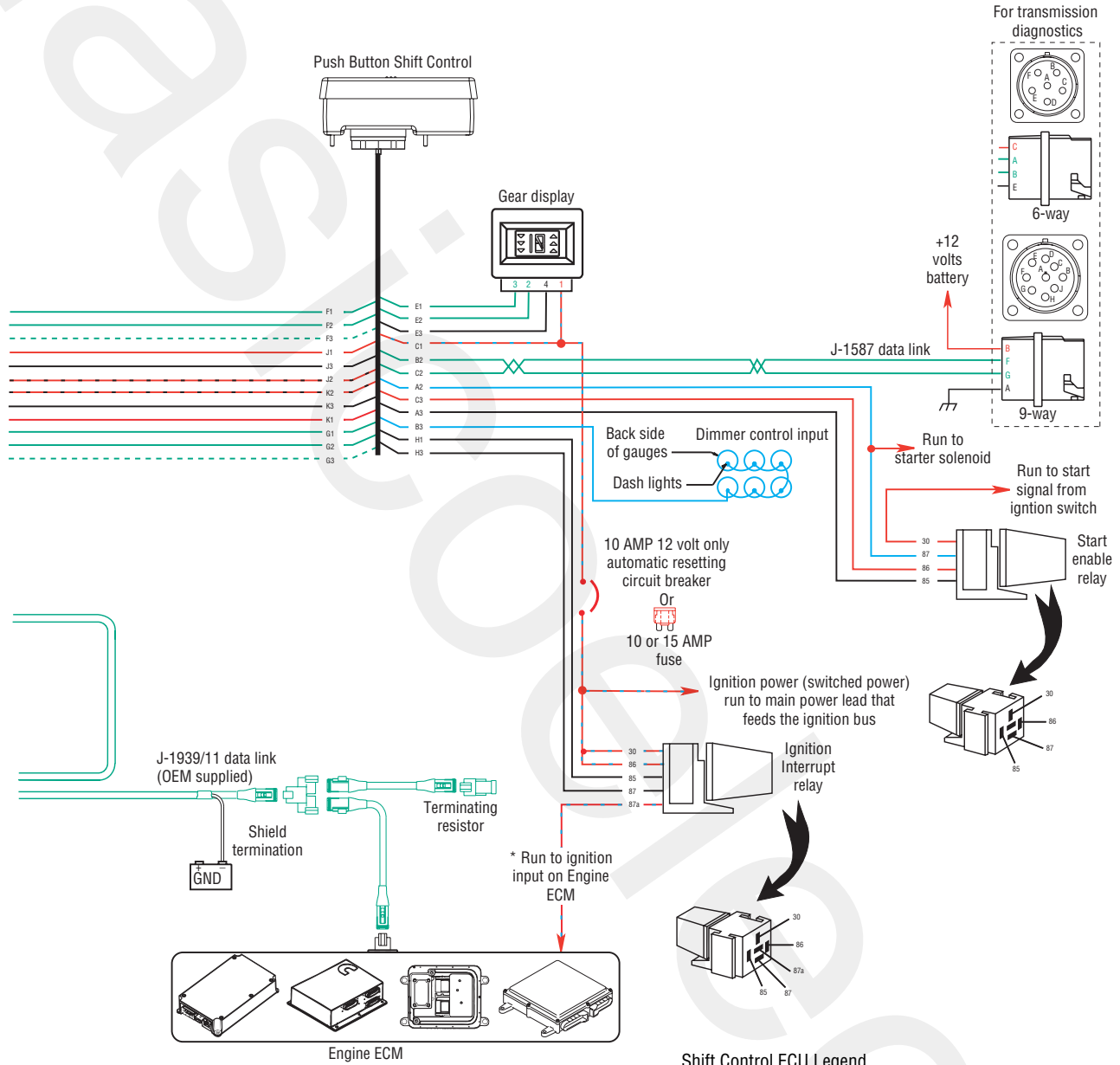

\* For vehicle/engine systems which use a vehicle system ECU, contact the Eaton OEM liaison for installation schematics

**Shift Control ECU Legend**  
 All OEM responsible wiring shown is "typical". Consult specific application.  
 (J1, K1, Run to Solenoid, Start: 30) = +12 volt non-switched from battery  
 (J2, K2) = +12 volt switched from shift control to transmission controller  
 (C1, Ignition Power, Ignition: 30, 86, 87a) = +12 volt switched from ignition switch  
 (A2-87) = Signals into the ECU  
 (F1, F2, F3, G1, G2, G3, E1, E2, B2, C2, J-1939) = Communication from and to the ECU  
 (J3, K3, E3, H3-87) = Signal returns, grounds, and general OEM wiring  
 (A3-85, H1-85) = -12 volt relay source  
 (C3-86) = +12 volt relay source

# 18-Speed AutoShift Wiring Diagram

## 18-Speed AutoShift Wiring Diagram

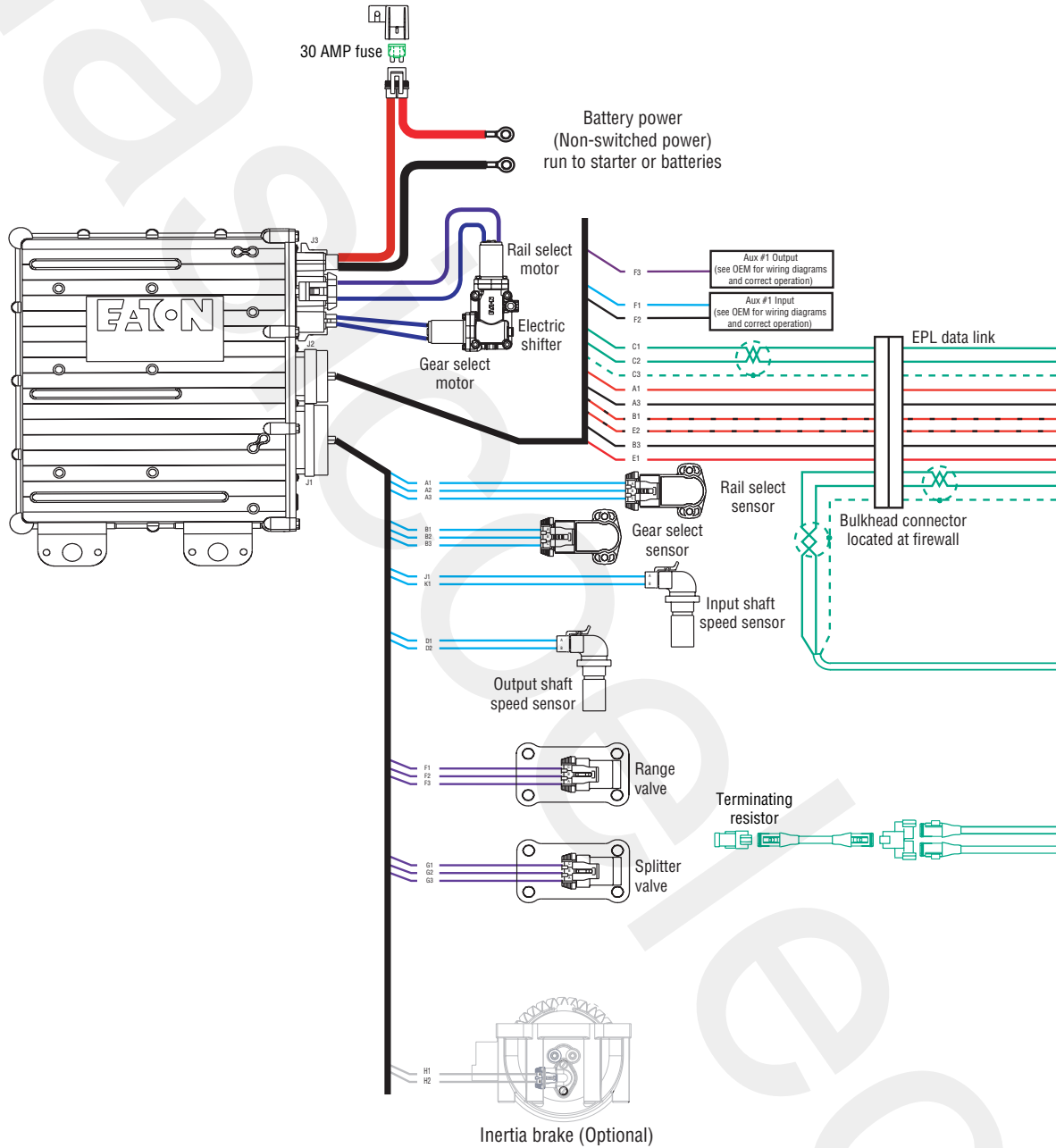

All OEM responsible wiring shown is "typical". Consult specific application.

(A1, E1) = +12 volt non-switched from battery

(B1, E2) = +12 volt switched from shift control to transmission controller

(F1) = Signals into the ECU

(C1, C2, C3, J-1939) = Communication from and to the ECU

(F2, A3, B3) = Signal returns, grounds, and general OEM wiring

(F3) = Aux output 1

# 18-Speed AutoShift Wiring Diagram

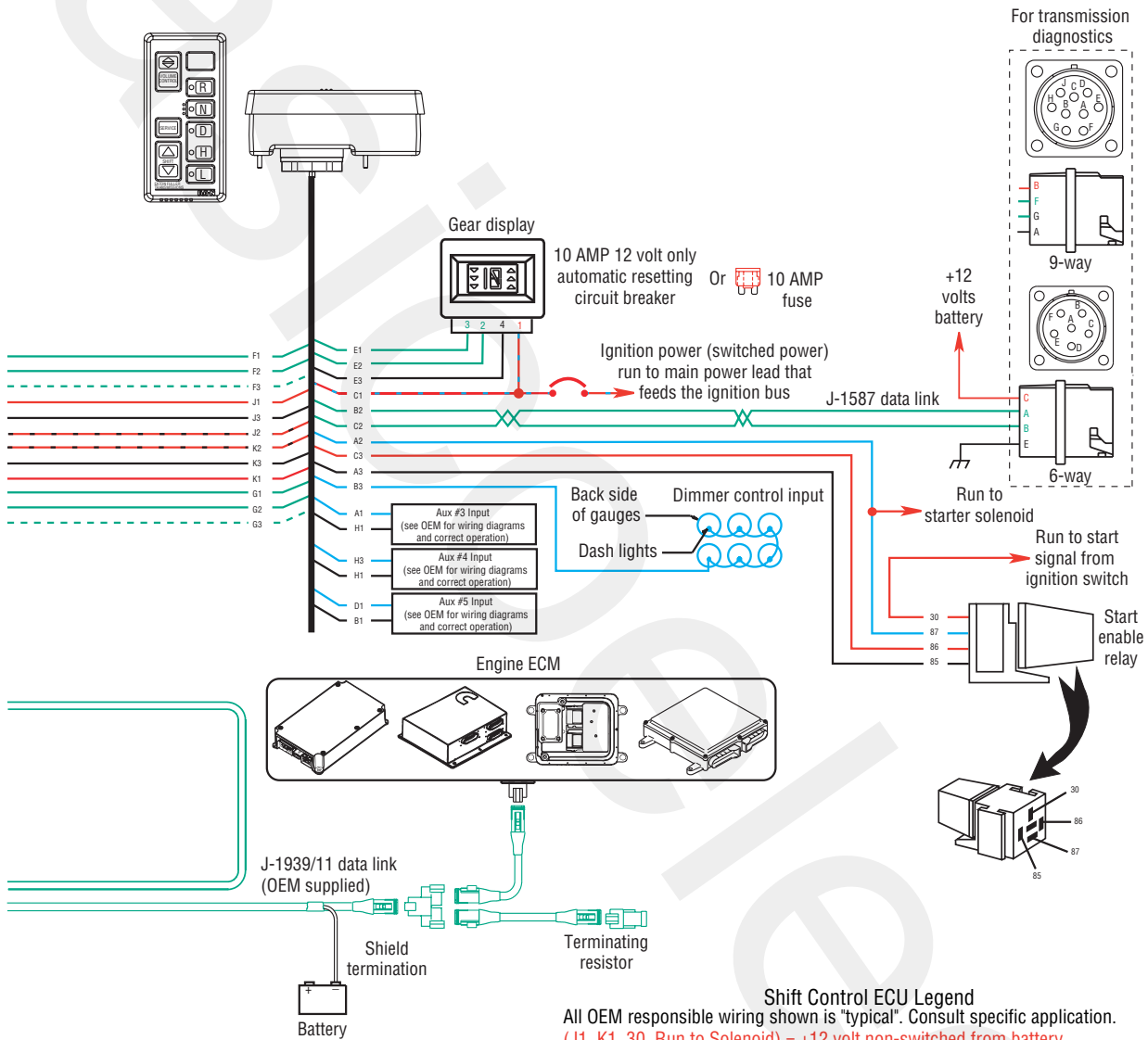

**Shift Control ECU Legend**  
 All OEM responsible wiring shown is "typical". Consult specific application.  
 (J1, K1, 30, Run to Solenoid) = +12 volt non-switched from battery  
 (J2, K2) = +12 volt switched from shift control to transmission controller  
 (C1) = +12 volt switched from ignition switch  
 (A2-87, B3, A1, H3, D1) = Signals into the ECU  
 (F1, F2, F3, G1, G2, G3, E1, E2, B2, C2, J-1939) = Communication from and to the ECU  
 (J3, K3, E3, H1, B1) = Signal returns, grounds, and general OEM wiring  
 (A3-85) = -12 volt relay source  
 (C3-86) = +12 volt relay source

## Eaton Shift Lever Wiring Diagram

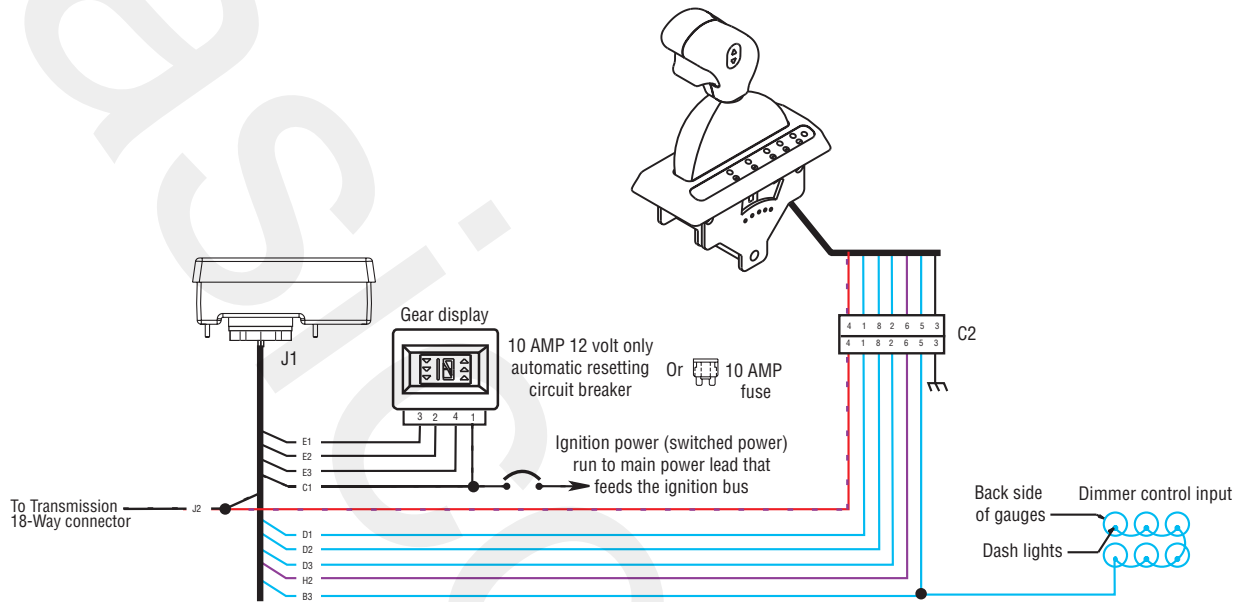

### Shift Lever Legend

All OEM responsible wiring shown is "typical". Consult specific application.

(J2-4) = +12 volt switched from shift controller to shift lever

(D1-1, D2-8, D3-2, B3-5) = Signals into the ECU

(3) = Signal returns, grounds, and general OEM wiring

(H2-6) = +12 volt signal from shift control to shift lever

OEM Shift Lever Wiring Diagram

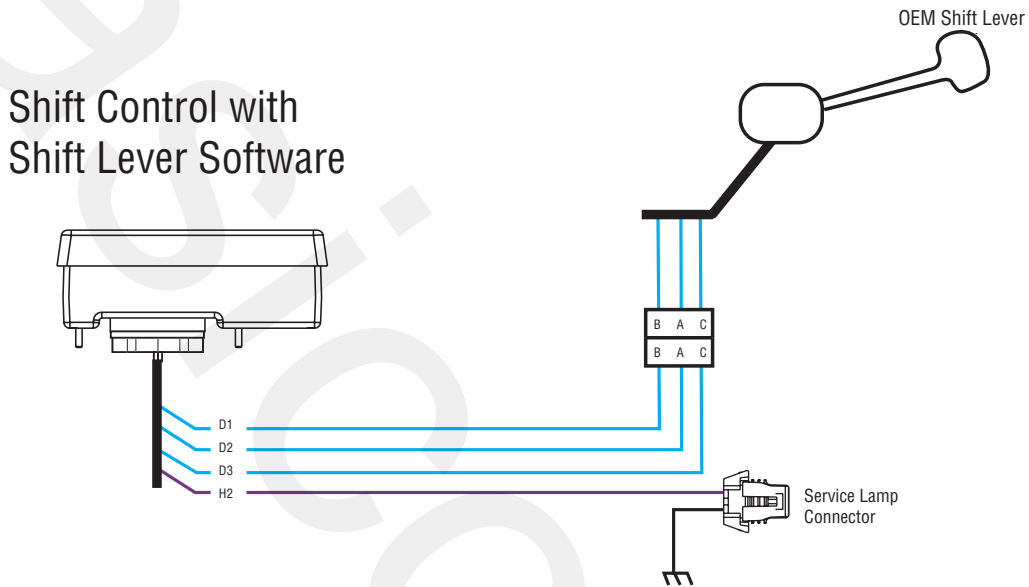

Shift Control with  
Shift Lever Software

OEM Shift Lever

Shift Lever Legend

All OEM responsible wiring shown is "typical". Consult specific application.

(D1-B, D2-A, D3-C) = Signals into the ECU

(H2) = +12 volt signal from shift control to shift lever

Resale

Copyright Eaton and Dana Corporation, 2007. EATON AND DANA CORPORATION hereby grants its customers, vendors, or distributors permission to freely copy, reproduce and/or distribute this document in printed format. It may be copied only in its entirety without any changes or modifications. THIS INFORMATION IS NOT INTENDED FOR SALE OR RESALE, AND THIS NOTICE MUST REMAIN ON ALL COPIES.



National Institute for  
**AUTOMOTIVE  
SERVICE  
EXCELLENCE**

**Roadranger®**



**EATON**

For specifying or service assistance, call 1-800-826-HELP (4357) 24 hours a day, 7 days a week (Mexico: 001-800-826-4357), for more time on the road. Or visit our web site at [www.roadranger.com](http://www.roadranger.com).

Roadranger: Eaton, Dana and other trusted partners providing the best products and services in the industry, ensuring more time on the road.